

Dimensions for FlexShade Systems

Motorized FlexShade

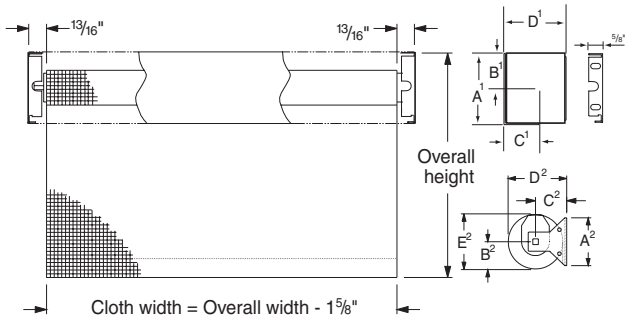

Headbox with Endcaps*		Brackets		*For fascia, subtract 1/16" from dimensions A ¹ and D ¹ .
Small	Large	Small	Large	
A ¹	3 ¹⁵ / ₁₆ "	4 ¹¹ / ₁₆ "	A ² 2 ¹ / ₂ "	3 ¹ / ₄ "
B ¹	1 ⁷ / ₈ "	2 ¹ / ₄ "	B ² 1 ³ / ₈ "	2"
C ¹	1 ³ / ₁₆ "	1 ⁹ / ₁₆ "	C ² 1 ⁵ / ₈ "	2 ¹ / ₄ "
D ¹	3 ⁷ / ₁₆ "	4 ¹¹ / ₁₆ "	D ² 3"	4 ¹ / ₄ "
			E ² 3 ¹ / ₁₆ "	4"

Refer to pricing charts beginning on page 9.

Clutch & Clutch XD FlexShade

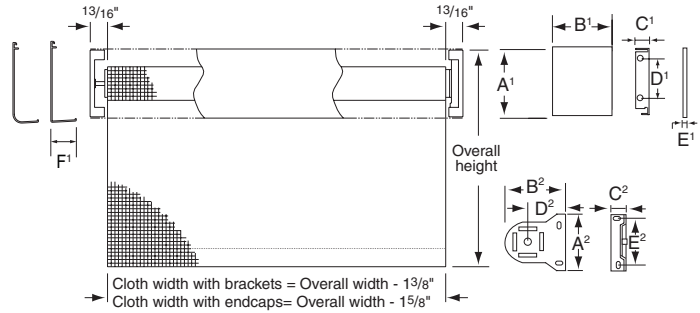

Headbox with Endcaps		Fascia with Endcaps		Brackets		
Small	Large	Small	Large	Small	Large	
A ¹	3 ¹⁵ / ₁₆ "	4 ¹¹ / ₁₆ "	3 ⁷ / ₈ "	4 ⁵ / ₈ "	A ² 2 ³ / ₁₆ "	2 ³ / ₁₆ "
B ¹	3 ⁷ / ₁₆ "	4 ¹¹ / ₁₆ "	3 ³ / ₈ "	4 ⁵ / ₈ "	B ² 2 ³ / ₈ "	3"
C ¹	5/8"	5/8"	5/8"	5/8"	C ² 1 ¹ / ₁₆ "	1 ¹ / ₁₆ "
D ¹	2"	3 ¹ / ₄ "	2"	3 ¹ / ₄ "	D ² 1 ⁵ / ₈ "	2 ¹ / ₄ "
E ¹	1/16"	3/32"	1/16"	3/32"	E ² 1 ³ / ₄ "	1 ³ / ₄ "
F ¹	1 ³ / ₁₆ "	1 ⁹ / ₁₆ "	1 ³ / ₁₆ "	1 ⁹ / ₁₆ "	F ² n/a	n/a

* Small brackets are standardly supplied with 10 lb. and 20 lb. clutch. Large bracket optionally available at Draper's discretion. For 24 lb. clutch or crank operator, contact Draper for dimensions.

Refer to pricing charts beginning on page 25 to determine which size is required for your installation. Above dimensions based upon 20 lb. clutch and 1 1/2" diameter roller.

Techmatic Shade Dimensions

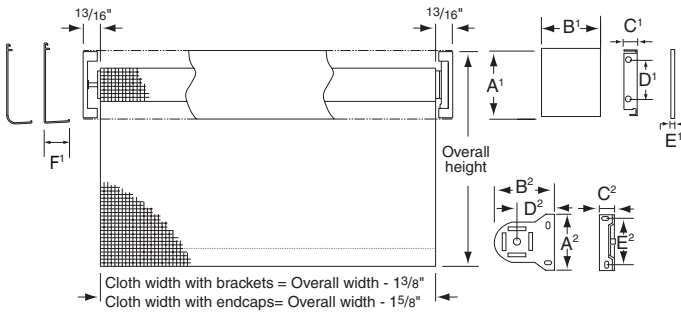

Headbox with Endcaps		Fascia with Endcaps		Brackets	
Small	Large	Small	Large	Small	Large
A ¹	3 ¹⁵ / ₁₆ "	3 ⁷ / ₈ "	A ² 2 ³ / ₁₆ "		
B ¹	3 ⁷ / ₁₆ "	3 ³ / ₈ "	B ² 2 ³ / ₈ "		
C ¹	5/8"	5/8"	C ² 1 ¹ / ₁₆ "		
D ¹	2"	2"	D ² 1 ⁵ / ₈ "		
E ¹	1/16"	1/16"	E ² 1 ³ / ₄ "		
F ¹	1 ³ / ₁₆ "	1 ³ / ₁₆ "	F ² n/a		

Refer to pricing charts beginning on page 36 to determine which size is required for your installation.

Spring Roller Shade

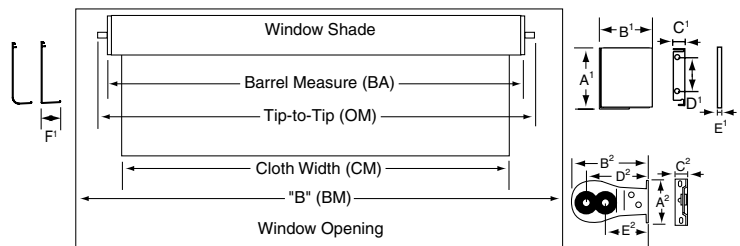

Headbox with Endcaps		Fascia with Endcaps		Brackets		
Small	Large	Small	Large	Small	Large	
A ¹	3 ¹⁵ / ₁₆ "	4 ¹¹ / ₁₆ "	3 ⁷ / ₈ "	4 ⁵ / ₈ "	A ² 1 ³ / ₈ "	1 ¹⁵ / ₁₆ "
B ¹	3 ⁷ / ₁₆ "	4 ¹¹ / ₁₆ "	3 ³ / ₈ "	4 ⁵ / ₈ "	B ² 2"	2 ⁵ / ₈ "
C ¹	5/8"	5/8"	5/8"	5/8"	C ² 5/8"	1 ³ / ₁₆ "
D ¹	2"	3 ¹ / ₄ "	2"	3 ¹ / ₄ "	D ² 1 ⁵ / ₈ "	2 ³ / ₁₆ "
E ¹	1/16"	3/32"	1/16"	3/32"	E ² 1 ¹ / ₄ "	1 ³ / ₄ "
F ¹	1 ³ / ₁₆ "	1 ⁹ / ₁₆ "	1 ³ / ₁₆ "	1 ⁹ / ₁₆ "	F ² n/a	n/a

Refer to pricing charts beginning on page 39 to determine which size is required for your installation.

Dual Roller with Fascia

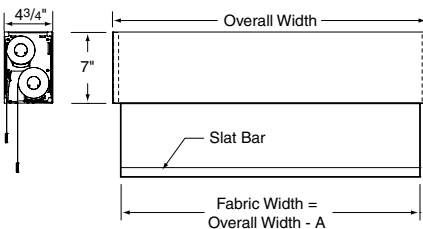

Operator	Dim A
110-220V Standard/ILT Motor	1 ³ / ₄ "
110-200V Quiet Motor	1 ¹⁵ / ₁₆ "
Battery/24V Motor	1 ¹¹ / ₁₆ "
Bead Chain Clutch	1 ⁵ / ₈ "