

Video Conferencing Camera Lift-Credenza

⚠ Caution

- ① Read instructions completely before proceeding.
- ② Follow instructions carefully. Installation contrary to instructions invalidates warranty.
- ③ **Do not obstruct operation of lift with fingers or any object. Serious injury or damage could result.**
- ④ **Do not permanently attach closure top to camera shelf. The top is designed to give way in case it comes in contact with fingers or other objects while closing.**
- ⑤ Installer must provide adequate structure, and must also secure furniture to wall to prevent tipping.

Note: Unit has been thoroughly inspected and tested at factory and found to be operating properly prior to shipment.

Parts and Hardware

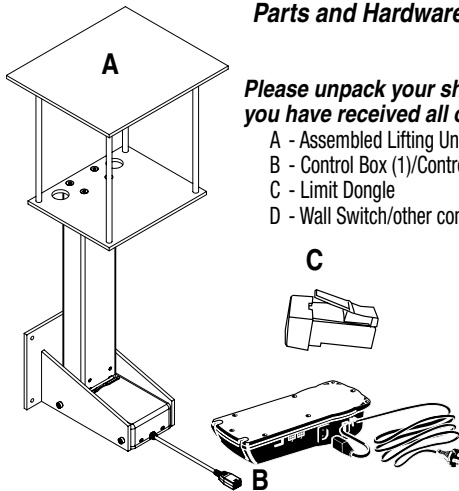

Please unpack your shipment and verify that you have received all of the items listed below.

- A - Assembled Lifting Unit
- B - Control Box (1)/Control Cable (1)/Power Cable (1)
- C - Limit Dongle
- D - Wall Switch/other controls (not shown)

Preparation

1. Provide cable and electrical access.
2. Mark and cut appropriately-sized opening for the Video Conferencing Camera Lift—Credenza. *Required opening in furnishing top is lift shelf size (width and depth) + 1/2" (see dimensional drawings on page 2).
3. Be sure unit is mounted so that when fully closed the top of the closure panel you will be using is flush with the surrounding cabinet surface.
4. Also be sure that when unit is fully open your camera is above the cabinet surface for unobstructed viewing, with the shelf remaining flush with or below the level of the cabinet surface. Please refer to dimensional drawings on page 2. This unit's vertical travel is 10".

Mounting

Please Note: Be sure unit is mounted so that when fully closed the top of the closure panel you will be using is flush with the surrounding cabinet surface. Also be sure that when unit is fully open your camera is above the cabinet surface for unobstructed viewing. Please refer to dimensional drawings on page 2. This unit's vertical travel is 10". Cabinetry or other mounting area should be prepared—cable access provided, etc.—before mounting the Video Conferencing Camera Lift.

1. Mark and pre-drill mounting surface so that the bottom of the mounting bracket is 29 1/2" below either the top surface of the cabinetry, or beneath the bottom of any closure panel you may be using to match the top surface of the cabinetry (you can either use the back plate of the mounting bracket as a template to mark the surface, or refer to dimensional drawings on page 2). This will allow the camera shelf to be flush with the cabinet surface when fully open.

2. Mount lifting column, control box and camera shelf assembly to mounting bracket inside cabinetry (see Fig. 1).

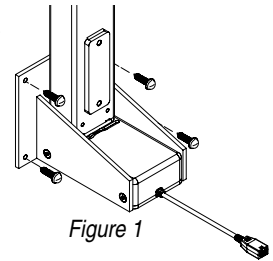

Please note: the exact position of the closure panel in relation to the cabinet top can be adjusted by cutting the four Camera Lift Support Bars which are used to attach the closure to the camera shelf.

Electrical Connections

Control unit operates on 120V, 60 Hz.
Actuator power rate is 18V AC, 10 amps.

If optional low voltage control or video interface control is specified and factory installed, please refer to wiring diagrams.

Unit is shipped with internal wiring complete and control switch fully boxed. Power cable with 120V plug, control cable connecting actuator to control unit and data cable connecting control box to wall switch or other controls included. Wiring must comply with national and local electrical codes. All operating switches should be "off" before power is connected.

Operation

⚠ Caution: Do not obstruct operation of lift with fingers or any object. Serious injury or damage could result.

When the unit is first connected to power, you must initialize using the following steps (**you must also do this to initialize the product any time it has been disconnected from its power source**):

1. Press & hold the DOWN button until the column is fully retracted—this is the END STOP position. Release the button.
2. Immediately press and hold the DOWN button for approx. 6 seconds, the column will travel out 5mm and then retract back to the END STOP.
3. It may be necessary to perform the initialization process twice as the system can be in different modes at start up.
4. The column is now initialized.

When operated, be cautious! Cycle unit down and up several times to confirm satisfactory operation.

110-120V SINGLE STATION CONTROL—UP-DOWN momentary switch permits operation to be stopped at any point. Unit stops when switch is released and may be restarted in either direction. Factory adjusted limit switches automatically stop unit when fully down or fully up.

110-120V MULTIPLE STATION CONTROL—Switches are similar in appearance to 110-120V Single Station Control. Unit stops when switch is released and may be restarted in either direction. Factory adjusted limit switches stop unit automatically when fully up or fully down.

24V CONTROL—UP-DOWN momentary switches stop at any point desired, operate in any sequence. Factory adjusted limit switches automatically stop unit when fully up or fully down. Installer should incorporate an all-pole disconnect in the fixed wiring.

RS232—Serial communication optionally available with wall switches, RF or IR remote. R2D7 converts ASCII commands into Draper controller commands.

Setting the Upper Travel Limit

1. Operate lift until it reaches the desired stopping (up) position.
2. Insert Limit Dongle into input on control box (see Fig. 2).

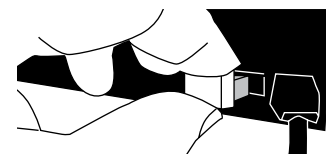
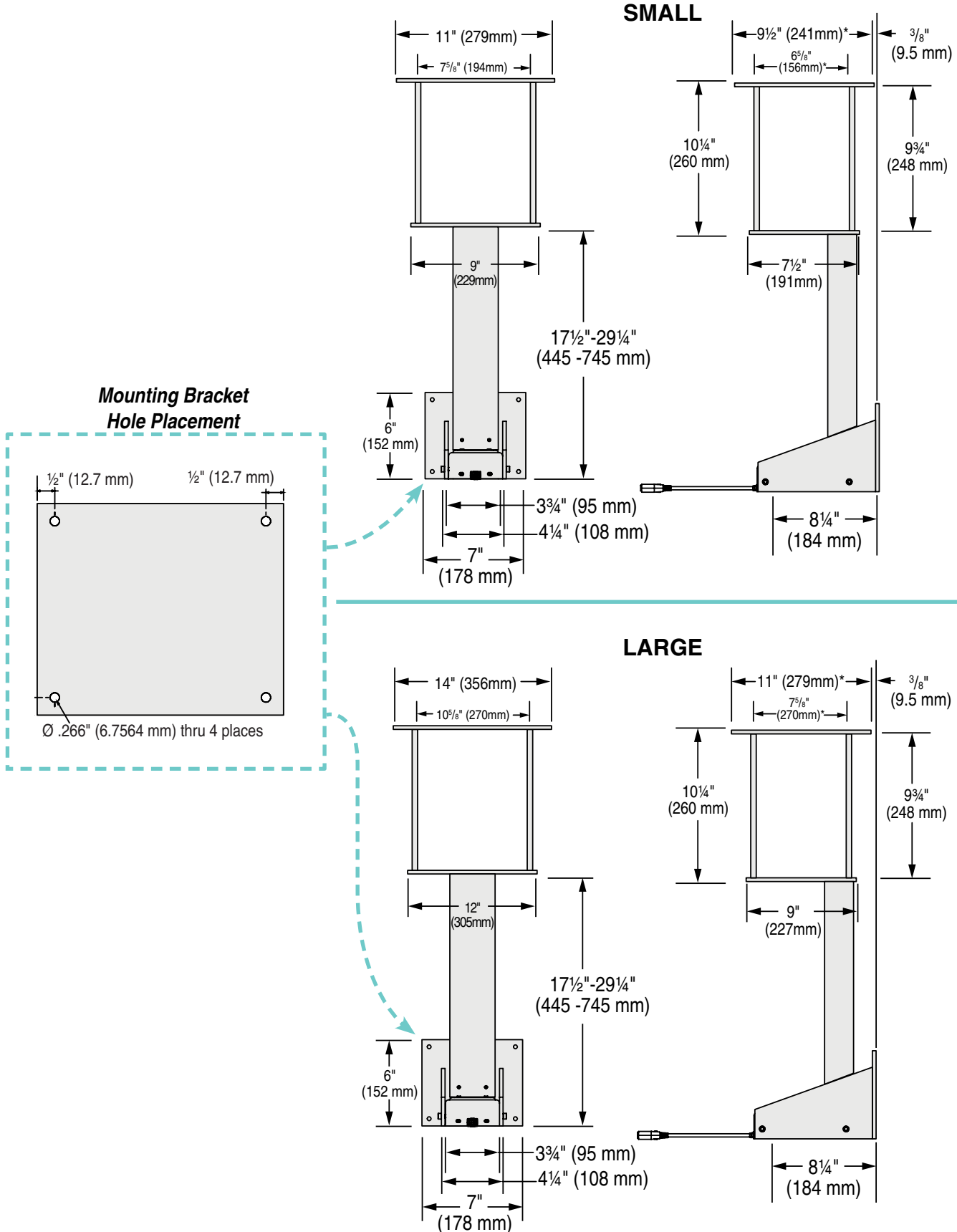

Figure 2

Video Conferencing Camera Lift Dimensions-Credenza



*Required opening in furnishing top is lift shelf size (width and depth) + 1/2" (12.7mm).

VCCL-Credenza Control Box

VCCL-Credenza—Standard Wall Switch (Momentary)

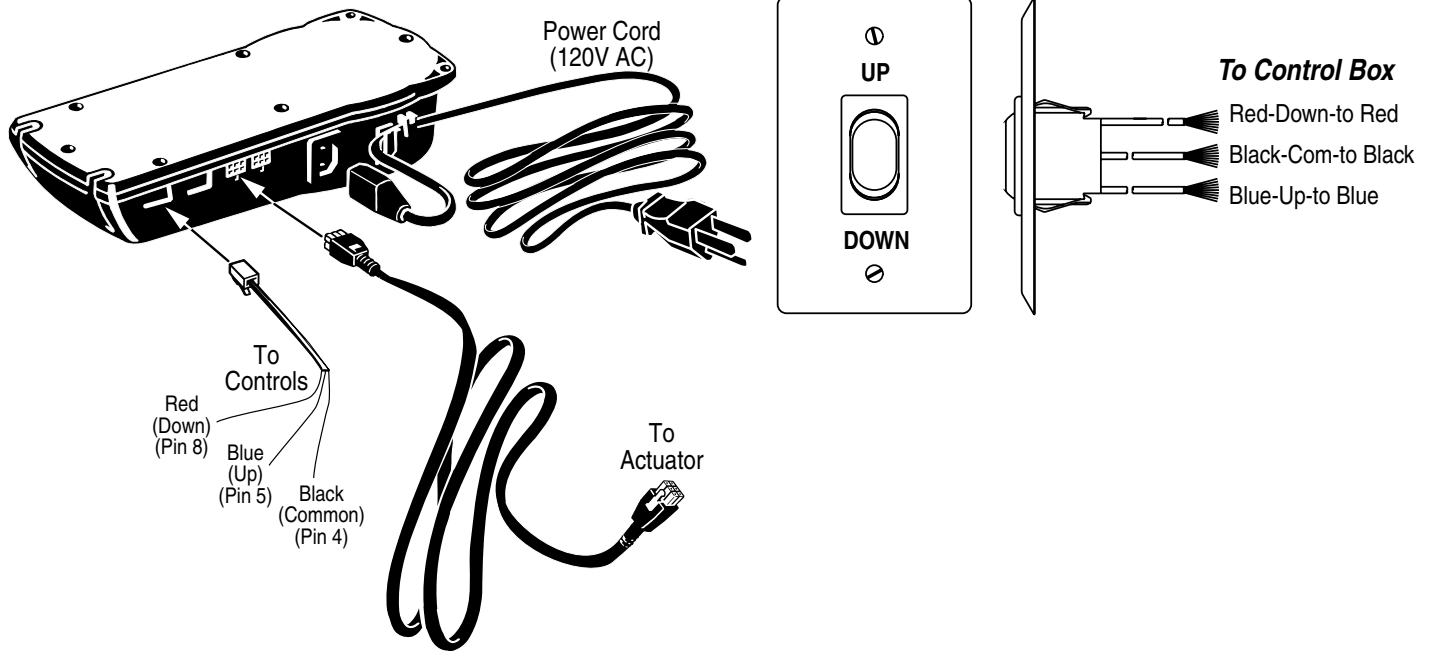

Wiring Diagram—External Low Voltage and Remote Control

----- Dashed wiring by electrician

External Serial Communication (RS232) with R2D7

