

220V Silhouette E & V Electric Projection Screen

INSTRUCTIONS INSTALLATION & OPERATION

⚠ Caution

- ① Read instructions through completely before proceeding; keep them for future reference. Follow instructions carefully. Installation contrary to instructions invalidates warranty. Care in mounting and correct operation will mean long and satisfactory service from your Draper screen.
 - ② Screen should be accessible for complete removal should fabric become damaged or should other service be required.
 - ③ Screen should be installed level (using a carpenter's level).
 - ④ Nothing should be fastened to screen dowel or viewing surface.
 - ⑤ Operating switch(es) packed separately in screen carton. Do not discard with packing material.
 - ⑥ Screen operates on 220V AC, 50 Hz., 1 ph. current.
- NOTE:** Screen has been thoroughly inspected and tested at factory and found to be operating properly prior to shipment.

These instructions are meant as a guide only. They do not imply any responsibility on the part of Draper, Inc. for improper installation or faulty workmanship at the jobsite.

Removing Shipping Brackets

DO NOT OPERATE SCREEN BEFORE REMOVING THESE SHIPPING BRACKETS FROM THE SCREEN CASE

- ① Loosen and remove fasteners from both bracket clamps that are attached to the screen case.
- ② Run the screen **DOWN** to expose bracket clamp fasteners attached to the screen dowel.
- ③ Loosen screws holding bracket to dowel endcap enough to remove the bracket.
- ④ Re-tighten dowel endcap screws.

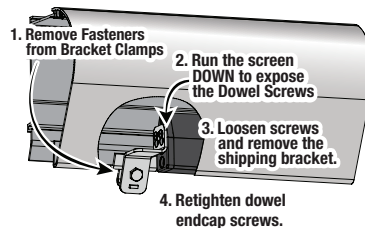

Installation

Your Draper screen can be mounted on a wall or suspended from the ceiling, or mounted on 15cm or 25cm-36cm extension brackets. *Extension brackets must be ordered separately from Draper.* With each method of installation, the case must be mounted level and with the flat back parallel to the wall.

To reduce the risk of personal injury, use only the hardware which comes with the screen or is specified in these instructions.

The screen (or wall extension brackets) should be mounted into studs or blocking in the wall/ceiling, or in drywall (minimum thickness 13mm) with specified anchors. For any other type of installation, follow all local building and safety codes.

Steel studs, concrete or cinder block walls and all other types of non-wood frame construction require the use of special screws or anchors. The selection of appropriate mounting hardware should be made by a qualified professional installer.

When locating viewing surface and checking clearance for screen's operation, remember surface is centered in case.

Take care to install wall/ceiling electrical box and conduit so they will be fully concealed by the screen case after installation.

Handle case carefully to avoid scratching.

Regardless of mounting method, screen should be positively and securely supported so that vibration or even abusive pulling on the viewing surface will not cause case to work loose or fall. Installer must insure that fasteners used are of adequate strength and suitable for the mounting surface chosen.

Wall Mounting

Mount two, three or four aluminum brackets provided ("Z" Clips) on the wall at desired height, using appropriate fasteners. Verify that they are in line and level to fully engage with the mounting lip on back of screen case. 4cm of free space is required above the "Z" Clips to allow case lip to be engaged over the lip of the "Z" Clips.

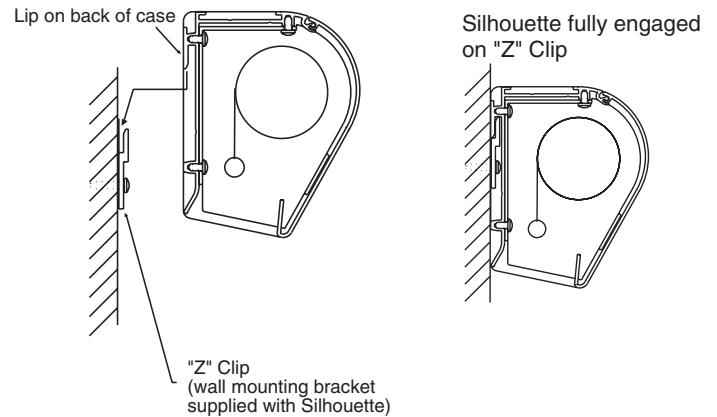

Engage the lip on back of screen case with lip of "Z" Clip and gently pull down to fully engage case to brackets.

Ceiling/Suspended Mounting

Locate two offset ceiling brackets (supplied) and slide these into the channel on top of screen case by aligning the chamfered edges of each bracket parallel to the channel length. Allow bracket to drop against bottom of channel and then rotate bracket counter-clockwise. Slide one bracket to each end of screen case until it stops against end cap of case. Tighten two set screws to lock bracket in place. Make sure that the flange of the ceiling bracket that has four holes is extended beyond the end caps of the case. Repeat above procedure for second ceiling bracket, making sure to slide it towards opposite end of case.

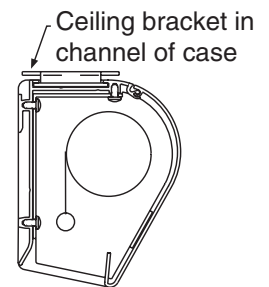

To mount against ceiling, hold screen case against ceiling and mark mounting hole locations. Each bracket has two holes towards the front edge and two holes towards the back edge. Installer must use at least two fasteners per bracket with one fastener in one of the two holes closest to back edge of bracket, and one fastener in one of the two holes closest to front edge of bracket. Installer must insure that fasteners are of adequate strength and suitable for the mounting surface chosen.

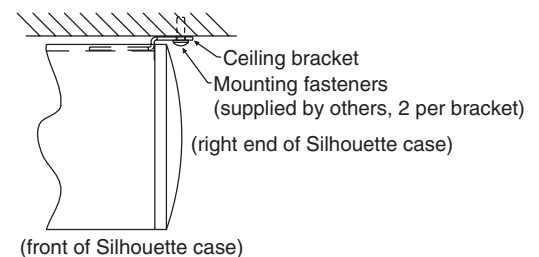

To mount suspended from ceiling, the brackets need to be installed on screen case as noted on page one. Attach "S" Hooks (supplied) through the holes in the brackets. Select the set of holes that allows the screen to hang in a vertical position. The installer is to provide the materials and fasteners to attach the "S" Hooks to the ceiling. Installer must insure that the fasteners and suspension material is of adequate strength and suitable for the mounting surface chosen.

If you have any difficulties installing or servicing your Electric Projection Screen, call your dealer or Draper, Inc.

Mounting on 15 cm extension wall brackets: 15 cm or 25-36 cm Extension Wall Brackets are needed to mount Silhouette extended from wall. Wall Brackets are not supplied with screen and must be ordered separately. Specify "Silhouette Extension Wall Brackets".

- ① Mount the Wall Brackets to the wall, making sure they are level and vertically plumb. Installer must insure fasteners (not included) are of adequate strength and suitable for chosen mounting surface.
- ② Attach hanging bracket to wall bracket as shown.
- ③ Attach (1) "Z" Clip and (1) Support Plate (supplied with screen) to hanging bracket as shown.
- ④ Engage the lip on back of screen case with lip of "Z" Clip and gently pull down to fully engage case to brackets.
- ⑤ Install hook bracket as shown making sure the two tabs of this bracket hook over the case extrusion.
- ⑥ Install #10-24 hex head screw through hook bracket, hanging bracket, and support plate as shown.

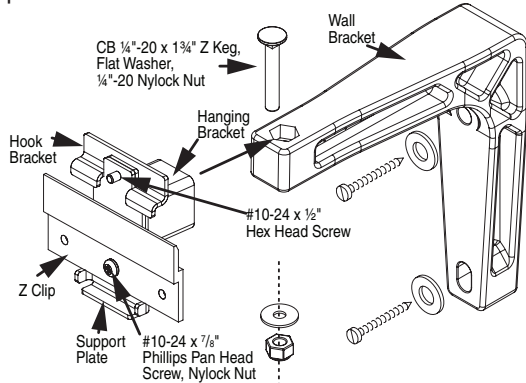

Removing Case Fascia

Caution: When removing or reattaching fascia, do not handle fascia by unpainted ends.

Case fascia is removable to access roller assembly. To remove fascia, depress outward the spring lip located inside lower front corner of screen case and pull lower corner of fascia outward. Repeat this at right end of case. Support fascia from center and rotate lower front edge upward approximately 40° to disengage the Roll-Lok hinge at the top front of screen case. Fascia can now be completely removed from case.

To install fascia, generally reverse instructions above making sure the Roll-Lok hinge is completely engaged before rotating fascia down towards the closed position. Depress spring clips outward, push lower corners of fascia inward until lips of spring clips hook behind fascia.

Please Note: Be sure the clips are completely up against the ends of the fascia.

Electrical Connections

Screen operates on 220V AC, 50 Hz., 1 ph current. .75 amp current draw. Duty Cycle: ON 28 seconds/OFF 4 minutes.

Junction box is located at left end of screen. It is accessible through front of screen case after fascia is removed (see instructions above for removing fascia). Electrical supply wires can enter through the back or top of case. For top entry, remove plug from top conduit hole and snap plug into hole on back side of case.

Junction box contains brown, black, and blue pigtail leads and green internal ground wire per wiring diagram attached.

If optional low voltage control or video interface control is specified and factory installed, please refer to wiring diagram on page three.

Wall or ceiling electrical box should be installed so as to be fully concealed by screen case after installation.

Screen is shipped with internal wiring complete and control switch(es) fully boxed. Wire to connect screen to switch(es) and switch(es) to power supply should be furnished by installer. Connections should be made in accordance with attached wiring diagram, and wiring should comply with national and local electrical codes.

All operating switches should be "off" before power is connected.

Operation

Before operating screen, remove any shipping brackets or tape securing fabric and dowel to the roller. If viewing surface is hanging out of the case 20 to 23 cm, tape has probably been broken by rough handling in shipment, allowing surface to "unwrap" one turn off the roller. Manually wrap fabric back around the roller without turning the roller itself.

When screen is first operated, be cautious! Cycle unit down and up several times to confirm satisfactory operation.

220V SINGLE STATION CONTROL—3-position UP-OFF-DOWN switch permits operation to be stopped at any point. Factory adjusted limit switches automatically stop screen when fully down or fully up.

220V MULTIPLE STATION CONTROL—(Not CE Approved) Switches are similar in appearance to 220V Single Station Control. Screen stops when switch is released and may be restarted in either direction. Factory adjusted limit switches stop screen automatically when fully down or fully up.

24V MULTIPLE STATION CONTROL—Three-button UP-STOP-DOWN switches stop at any point desired, operate in any sequence. Factory adjusted limit switches automatically stop screen when fully down or fully up. Installer should incorporate an all-pole disconnect in the fixed wiring.

220V & 12V VIDEO INTERFACE CONTROL—(Not CE Approved) Allows screen to be controlled by a trigger signal—when the signal comes on, the screen descends automatically.

KEY OPERATED SWITCHING—(Not CE Approved) Two kinds of key-operated switches are optionally available with this unit.

- ① The key-operated power supply switch controls power to the screen and switches. When it is "off", the switches will not operate screen. Key may be removed from the switch in either "on" or "off" position.
- ② A three-position key switch permits the screen to be operated directly by key. In this case, the screen's operator must always have a key.

RS232/ETHERNET—Serial communication and network communication optionally available.

Caution: Do not remove the roller assembly from the case unless necessary for repairs. If the roller assembly is removed, be sure motor is fully re-seated in the bracket. If mounting style incorporates a retaining spring (left below), be sure the retaining spring is reinstalled.

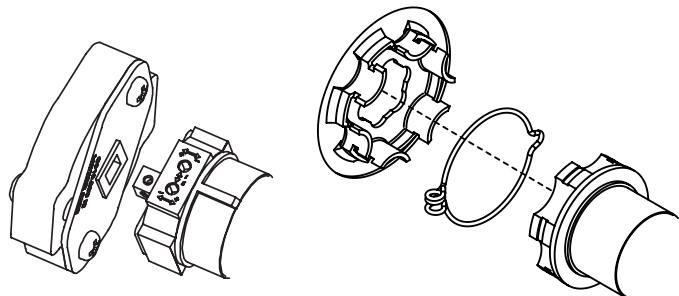

Tab-Tension Adjustment Procedure

Draper's Tab-Tensioning System is factory-set, and under normal circumstances will not require field adjustment.

If, however, you notice wrinkles, waves or other indications that the tensioning cables need to be adjusted, follow the procedure below.

- ① Determine which side requires adjustment.
- ② Secure dowel with one hand.
- ③ Using Phillips-head screwdriver, depress spring-loaded adjustment screw and slowly turn **CLOCKWISE TO INCREASE** tension, or **COUNTER-CLOCKWISE TO RELEASE** tension. The screw adjusts in 60° turn increments. Adjust only **one increment (60° turn)** at a time
- ④ If problem is not corrected, leave screen in position for 24 hours to allow surface material to stretch into position.
- ⑤ If problem still is not corrected, repeat steps 2 and 3.

⚠ Caution: Do not touch or bend surface.

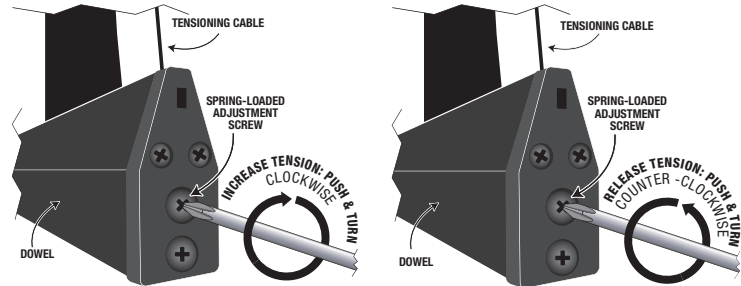

Limit Adjustments—Standard Motors

Please Note: Screen limits are factory set for optimum performance of the screen. A procedure is outlined below for minor tweaks, but any adjustment of these limits may negatively affect the flatness of the screen surface and could also void the warranty. Please check with Draper prior to resetting screen limits.

⚠ CAUTION: Always be prepared to shut screen off manually when new adjustment is being tested. Screen may be severely damaged if viewing surface is allowed to run too far up or too far down.

⚠ CAUTION: Be sure all switches are in "off" position before adjusting limit switches.

The motor limit screws are normally located on the audience left of screen roller.

"DOWN" LIMIT ADJUSTMENT

To Reduce Screen Drop

- ① Raise screen surface about 30 cm (1') above desired setting and turn off.
- ② Turn the DOWN limit screw (White or (I)) clockwise (three screw turns = ½ roller revolution).
- ③ Test by running screen down repeat steps 1 & 2 until desired position is reached.

To Increase Screen Drop

- ① Run screen to the down limit.
- ② With the down switch on, turn the DOWN limit screw (White or (I)) limit screw counterclockwise (three screw turns = ½ roller revolution) to increase drop.
- ③ Test by running screen up about 1' and back down to new down limit.
- ④ Repeat steps 2 and 3 until desired position is reached.

"UP" LIMIT ADJUSTMENT

Screen is Running Too Far Up

- ① Lower screen surface about 30 cm (1') below desired setting and turn off.
- ② Turn the UP limit screw (Yellow or (II)) clockwise (three screw turns = ½ roller revolution).
- ③ Test by running screen up.
- ④ Repeat steps 1 through 3 until desired position is reached.

Screen Needs to Run Up More

- ① Run screen down about 1' and turn off.
- ② With the up switch on, turn the UP limit screw (Yellow or (II)) limit screw counterclockwise (three turns of screw = ½ roller revolution).
- ③ Repeat steps 1 and 2 until desired position is reached.

⚠ CAUTION: Do NOT allow the dowel to wrap up over the roller when the screen is running up! This could damage the screen.

Limit Adjustments (Built-in Low Voltage Motors)

Please Note: Screen limits are factory set for optimum performance of the screen. Any adjustment of these limits could void the warranty. Please check with Draper prior to resetting screen limits.

⚠ CAUTION: Always be prepared to shut screen off manually when new adjustment is being tested. Screen may be severely damaged if viewing surface is allowed to run too far up or too far down.

⚠ CAUTION: Be sure all switches are in "off" position before adjusting limit switches. (Height adjustments are made from wall switch)

- ① Connect the ILT switch to the motor via the terminal blocks, or via the modular port using four conductor modular cable. When using modular cable, the cable connectors **MUST NOT** be crimped in reverse, as with standard telephone cable.
- ② Set the slide switch to the lower position. Press and hold the DOWN button on the switch to move the viewing surface to the desired lower limit. If the screen moves in the opposite direction, release the DOWN button and press and hold down the STOP button for four seconds. This will reverse the operation of the UP and DOWN switches.
- ③ Move slider switch into center position. Wait a couple of seconds.

Please Note: If you move the slider switch from down to up in one motion it sets the two limits in the same position.

- ④ Set the slide switch to the higher position. Move the viewing surface to the desired upper limit by pressing and holding the UP button on the wall switch.
- ⑤ Return the slide switch to the center position to return to normal operation.
- ⑥ To set the viewing surface to an alternate format position, move the viewing surface to the desired position and press the STOP button. Press and hold the STOP button for at least three seconds to record the position.

Back View of Wall Switch

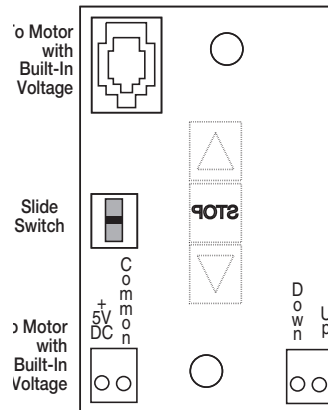

Please Note: 5V DC must be connected to be able to set limits using the wall switch.

Please Note: Pressing and releasing the UP button on the switch will move the screen to its upper limit. Pressing and releasing the DOWN button will move the screen to its lower limit.

While the motor is in motion, pressing the STOP button for less than two seconds will stop the viewing surface at its present position.

Once the motor is stopped, pressing the STOP button will move the viewing surface to its alternate format position.

Pressing and holding the STOP button, when the motor is at rest or in motion, for at least three seconds will record a new alternate format position.

Case Dimensions

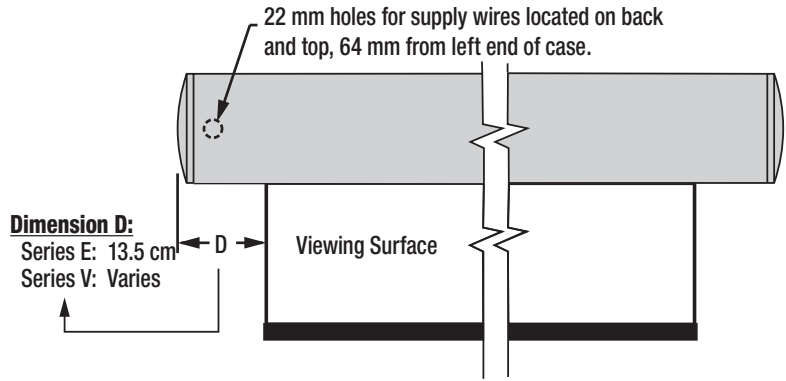
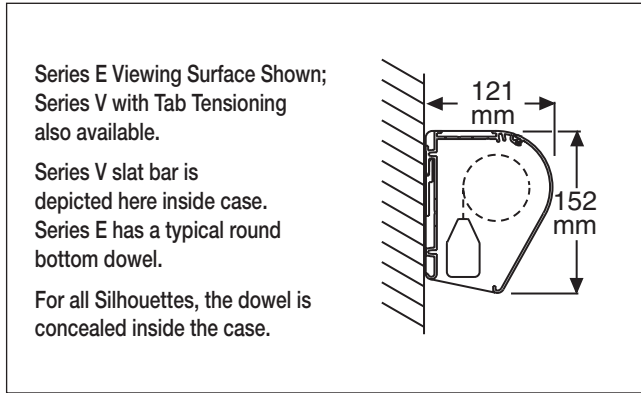

Wiring Diagrams

Please Note: Do not wire motors in parallel.

Wiring Diagrams—220V Motor and Quiet Motor

Wiring Diagrams—220V Motor and Quiet Motor with Built-in Low Voltage Controller

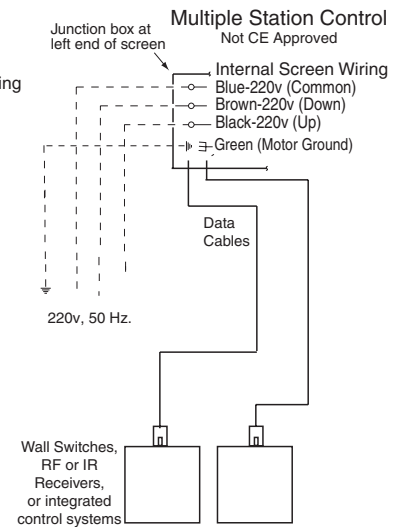
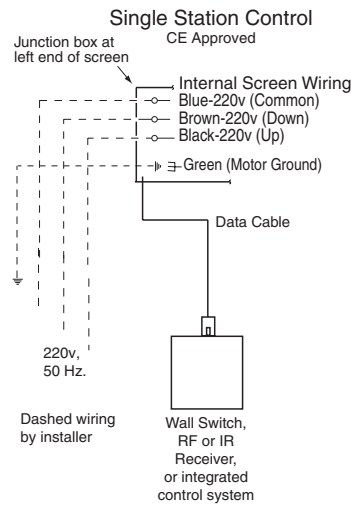
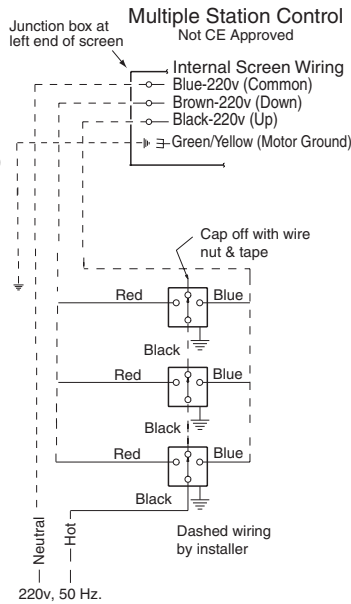
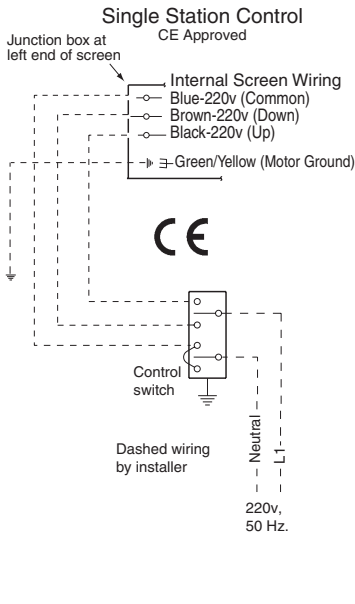

Wiring Diagrams—Plug & Play 220V Motor with Built-in Low Voltage Controller

Single Low Voltage Control

Multiple Low Voltage Controls

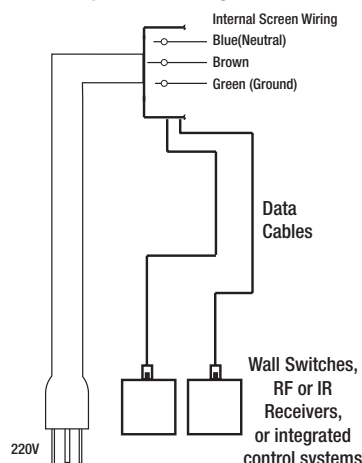
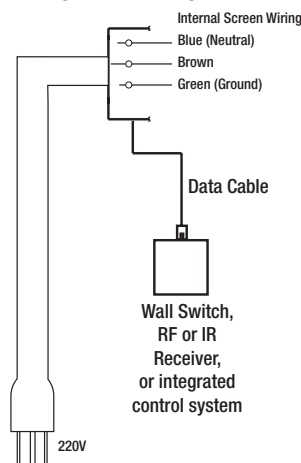

ILT Switch-to-Motor—Dry Contacts or Data Cable connection

Back of wall switch.

Please Note: 5V DC must be connected to be able to set limits using the wall switch.

Please Note: Although both Dry Contact and Data Cable connections are shown, you should only use one connection type per motor.

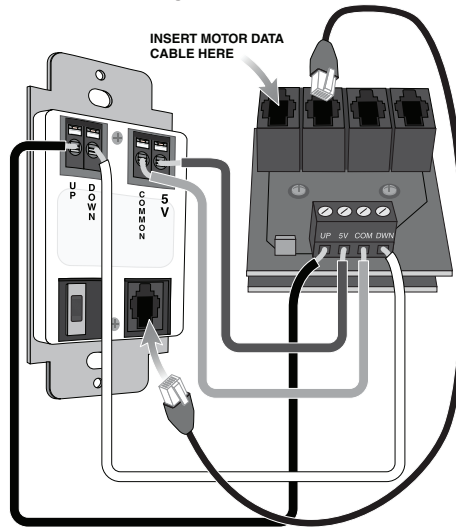

Please Note: This Splitter/ Jack is located inside the junction box of your screen.

Data Cables to switches or to additional motors can be plugged into any of the three open jacks. If this is a "Case First, Screen Later" installation, plug the motor cable into the jack indicated in the drawing.

External LVC-IV - Single or Multiple Projection Screen Wiring Diagram

INTERNAL SCREEN WIRING

