

# Installation Instructions

## RPX Rear Projection System by Draper

### Caution

- ① Inspect your Draper rear projection screen immediately upon delivery. RPX units may ship in up to three crates, which may be bolted together for shipping. After inspection has been made, the shipping crates should be sealed until installation.
- ② Before beginning assembly/installation, compare the custom as-built drawings with the pieces you have, and make sure you have received the proper RPX system and that all parts are included.
- ③ Make sure RPX is installed level and square. If unit is not level, or not square in relationship to the projection screen, "keystoning" or other problems will be encountered.
- ④ All tools and hardware for assembly are included; do not discard.
- ⑤ Installation instructions for your Draper rear projection screen are shipped with the screen.
- ⑥ Take great care when handling the mirror. Projector Side is delicate and will usually come covered with a protective plastic film. Remove film after installation and prior to projecting images. If cleaning is necessary, a mirror cleaning kit is available; contact Draper. You may also clean lightly with glass cleaner and a soft, lint free cloth.
- ⑦ Assemble all components of the mounting system with nuts and bolts securely tightened.

*These instructions are meant as a guide only. They do not bind Draper, Inc. in any way and do not imply responsibility of Draper, Inc. for improper installation or faulty workmanship at the jobsite.*

### Receiving

All Draper rear projection screens are shipped (with installation instructions) in durable wooden crates and packaged in accordance with accepted standards for this type of material. However, occasionally a shipment will incur freight damage due to particularly rough handling in transit. **Your Draper rear projection screen and RPX unit should be inspected immediately upon delivery.** Any obvious damage should be noted on the freight bill when the shipment is received. If concealed damage is discovered, an inspection by a representative of the delivering carrier must be made within 14 days following receipt of shipment. Neither Draper, Inc. nor our dealer can accept responsibility for claims arising from merchandise damaged in shipment unless the above procedure is followed. After inspection has been made, the shipping crate should be sealed until installation.

**NOTE: Draper rear screens are extremely delicate. All Draper rear projection screens should be handled and stored upright at all times.**

### Unpacking

All Vortex, Cinescreen, DiamondScreen™ and IRUS crates are labelled on the "PROJECTOR SIDE." Open crates only from the side marked "OPEN THIS SIDE." Use extreme care in unpacking to avoid scratching the lens surfaces. Do not use knives to remove wrapping. Use soft cotton gloves, a soft cloth or tissue paper as a hand pad.

### Installation

Make sure all other aspects of construction have been completed before rear screen installation, including painting and cleanup. If additional construction work must be done after installation, cover screen with clear polyethylene sheeting until all work has been completed.

Draper screens should not be cut or altered in the field. Any alteration of a Draper screen after it leaves our plant automatically voids product warranty. It is imperative that Vortex, DiamondScreens™ and High Contrast Black screens be installed with the Fresnel lens (circular pattern) facing the projec-

tion room and the linear lens (straight pattern) facing the audience.

IRUS and Holo-View screens must be installed with side marked "audience side" facing audience.

Cinescreens® work equally well with the optically coated side facing the projector or the audience. Rear projection screens are most frequently mounted with the optically coated side toward the audience, as this greatly reduces glare and reflections from ambient light in the audience area. However, care must be taken on screens so mounted to protect the coated surface from accidental damage or abuse.

A Draper screen with a factory-installed System 400 frame can only be mounted in an opening one way: with the frame trim toward the audience. No finish carpentry work is required with a System 400 frame.

A Draper screen with a factory-installed System 100, 200 or 300 frame must be mounted within a finished opening. See screen instructions for installation drawings.

### Cleanup

If cleaning is necessary, a mirror cleaning kit is available; contact Draper. Dust may be removed from Draper rear projection screen surfaces with a soft, clean cloth. For removal of stains or soil marks use a cloth or sponge and a mild soap and distilled water solution. Wring free of excess moisture before applying, rinse and blot dry. Do not rub. Do not use solvents of any type without Draper's recommendation.

### Minimum Tools Required

- 1—½" hex head Wrench, provided
- Carpenter's Level

### RPX Components

- 1—First surface mirror assembly
  - 1—Mirror and projector mounting system
  - All required fasteners (½" hex head with 5/16"-18 threads)
  - Projector mounting screws
  - Tools required for assembly
  - Levelers
- NOTE: *Projector not included*

**NOTE: Some custom RPX units may not be represented here. If you have questions upon receiving your RPX, contact Draper, Inc.**

### A Note About Projector Placement

Each projector requires a different placement on Draper's RPX. Specific projector placement information is provided by Draper, Inc. for each installation. See projector mounting instructions.

### Six-Axis Adjustment System

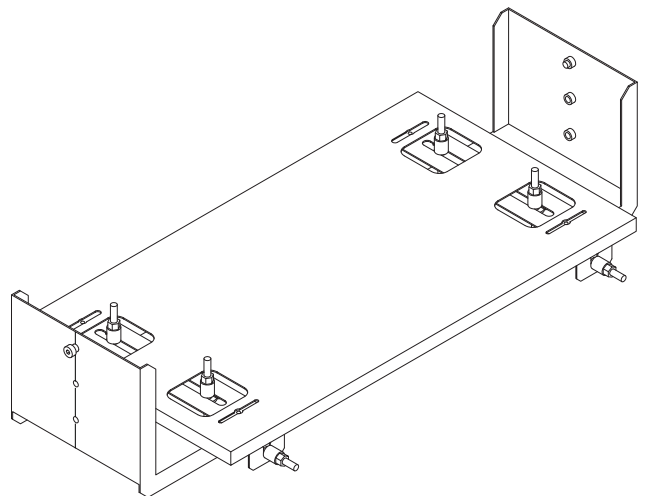

*If you encounter difficulties installing or servicing your Rear Projection System, call your dealer or Draper, Inc., Spiceland, Ind., (765) 987-7999; or fax (765) 987-7142.*

# DRAPER®

411 S. Pearl St., Spiceland, IN 47385 USA ■ 765-987-7999  
www.draperinc.com ■ fax 765-987-7142

Copyright © 2011 Draper Inc.

Form RPX\_Inst11

Printed in U.S.A.

## Parts List—RPX with Six-Axis Adjustment System

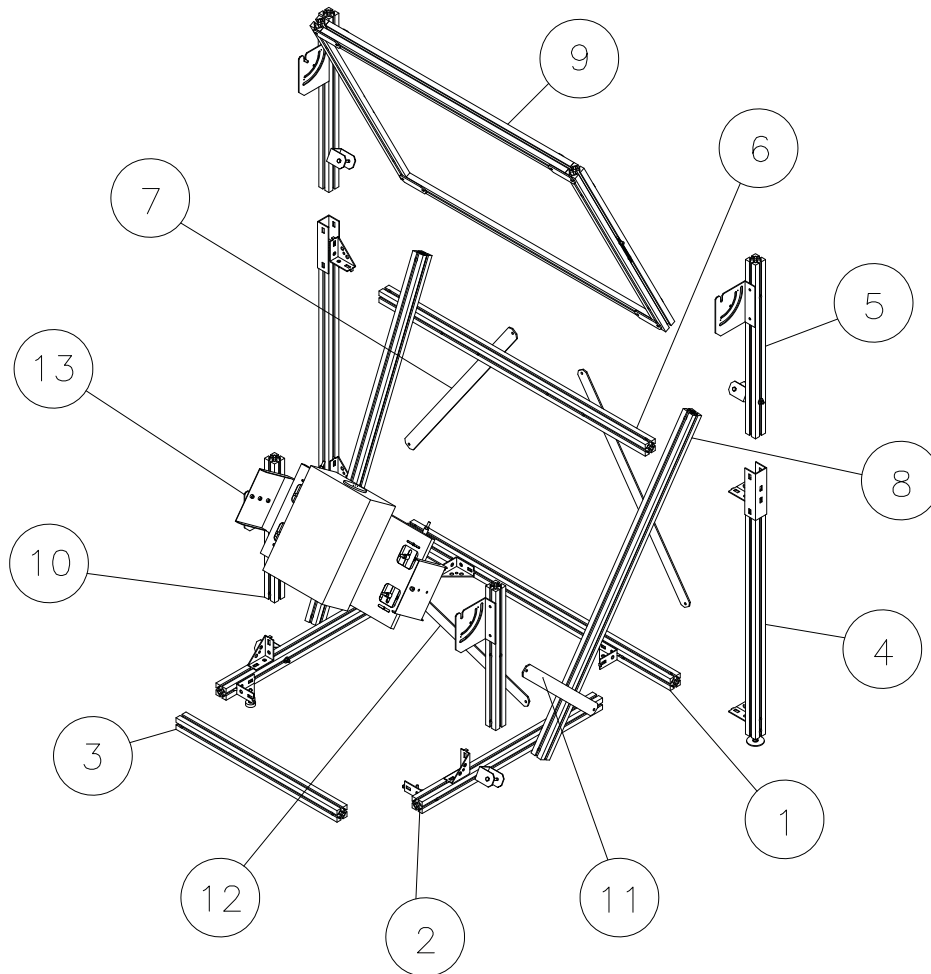

<b>Parts List</b>			
<b>Item</b>	<b>Qty.</b>	<b>Part Description</b>	<b>Note</b>
1	1	Mirror Crosstie	
2	2	Projector Base	
3	1	Projector Crosstie	
4	2	Lower Mirror Stand	
5	2	Upper Mirror Stand	
6	1	Mirror Stand Cross Brace	
7	2*	Mirror Stand Diagonal Brace	Flat Bar
8	2	Compound Diagonal Brace	
9	1	Mirror Assembly	
10	2	Projector Stand	
11	2*	Projector Stand Diagonal Brace	Flat Bar
12	1*	Projector Stand Cross Brace	Flat Bar
13	1	Projector Mount**	Various
		*TBD	
		**Six-Axis Adjuster is shown	

## RPX Assembly

- ① Remove parts from cartons. Make sure all parts have been received.
- ② Position the projector stands and base, and bolt together with T-bolts and  $\frac{7}{16}$ " nuts, making sure they are tight.

**Please Note: The RPX unit assembles using brackets and bolts, most of which are already in place.**

- ③ Position the rest of the RPX frame pieces and continue to bolt together unit, working your way up from the floor.

**Please Note: Assemble RPX unit in the following order: Base, Projector Mounts, Mirror Stand, Mirror, Projector.**

- ④ Hand tighten the bolts at this time. Once you have assembled the complete unit, tighten all bolts using wrenches.



Figure 5



Figure 1



Figure 6



Figure 2



Figure 7



Figure 3



Figure 8—Six-Axis Adjustment System



Figure 4

- ⑤ Install the projector onto the Six-Axis Adjustment System. Then, bolt this assembly to the projector cradle (see Fig. 8 for photo of the Six-Axis Adjustment System):
  - A) Position the projector onto its top on a soft surface, unless specifically directed not to do so by the projector manufacturer;
  - B) Position the projector so the lens is pointing in the direction per the projector mounting instructions.

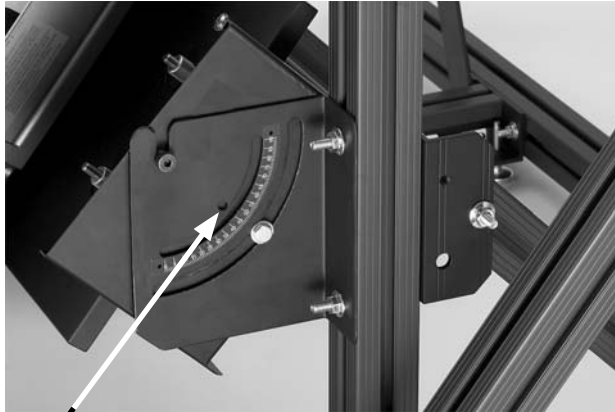

Figure 9

**Line up 1/4" holes for factory setting of cradle and mirror thru alignment holes.**

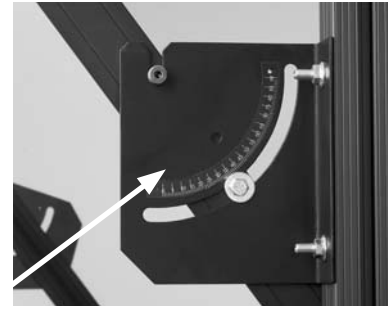

Figure 11

tion and prior to projecting an image. To determine projection side, place your finger on one side of the mirror. If your finger meets its reflection tip-to-tip, that side is the projection side. If there is a space between your finger and the reflection, that is the side facing away from the projector. Install the mirror assembly to the pivot plates (See Fig. 11). Note: The shoulder bolt goes in the slot at the top of the pivot plate. Rotate mirror assembly until alignment hole in mirror angle and pivot plate are aligned. Insert bolt (1/2" hex head with 5/16"-18 threads) thru alignment holes.

- ⑧ After all components have been assembled, make sure all nuts and bolts are securely tightened.



Figure 10—typical assembly (before mirror attachment)

- C) Bolt projector to platform, noting proper lens direction, then bolt this assembly to the cradle.
- ⑥ With the projector properly attached, install this assembly to pivot plates. Note: The installed shoulder bolts on the cradle install in the slot at the top of the pivot plates. See installation drawing for your particular application to insure proper orientation of projector and cradle to pivot plates. Rotate cradle assembly until alignment holes in pivot plate and cradle are aligned. Insert 1/4" bolt through alignment holes. See Fig. 9.
- ⑦ **This step requires two people!**  
Note: Mirror surface direction is important. Install the mirror assembly so projection side of the mirror is towards the screen. Projection side may be covered with a protective plastic film, which must be removed after installa-



Position unit at the recommended location for your system as instructed on the Installation Drawing. Using the supplied levelers, insure that the unit is level. If desired the unit can be anchored to the floor using anchor bolt holes provided. Use included Adjustment Procedures to correct for image problems.





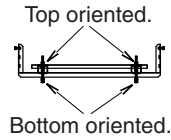

**Please Note: To confirm correct assembly, check the project drawing provided with your RPX unit. You will find a dimension indicating the distance from the screen to the mirror upright. Measure your assembled RPX unit and make sure the actual measurement matches what is indicated on the drawing.**

## Adjustment Procedure for Six-Axis Adjustment System

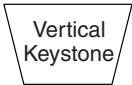
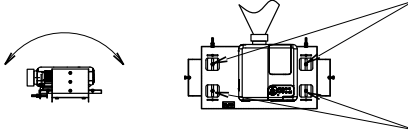
Before beginning adjustment procedure, check that rear projection device is leveled, positioned the correct distance from the screen and is centered and parallel to the screen.

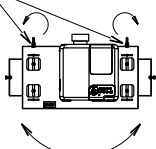
Note that control knobs may be top or bottom oriented.

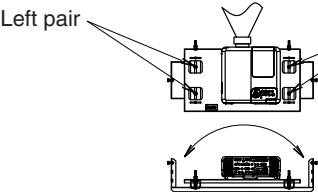
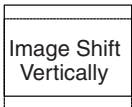
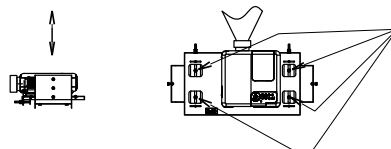
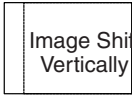
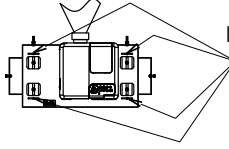

Problem	Solution
 <p>Vertical Keystone</p>	<p>Pitch Adjustment</p>  <p>Turn these two knobs together in the same direction. (Note: rear pair can also be used.)</p> <p>Rear pair</p>
 <p>Horizontal Keystone</p>	<p>Yaw Adjustment</p> <p>Turn two front knobs in opposite direction.</p> 
 <p>Skewed Picture</p>	<p>Roll Adjustment</p>  <p>Left pair</p> <p>Turn these two knobs together in the same direction. (Note: left pair can also be used.)</p>
<p>Screen</p>  <p>Image Shift Vertically</p>	<p>Vertical Shift</p>  <p>Turn all four knobs equal number of turns in the same direction.</p>
<p>Screen</p>  <p>Image Shift Horizontally</p>	<p>Horizontal Shift</p>  <p>Loosen four Philips head screws enough to manually shift plate to the left or right then tighten.</p>
<p>Screen</p>  <p>Image Sizing</p>	<p>Image Sizing</p> <p>Turn two front knobs in the same direction.</p> 