

Section 1 - Receiving

Draper ships all IRUS rear projection screens in durable wooden crates and packages the screens in accordance with accepted packaging standards for this type of material.

However, rear screens are expensive and delicate, and occasionally a shipment will incur freight damage due to particularly rough handling in transit.

Please Note: Inspect IRUS rear projection screens immediately upon delivery.

Note any visible damage on the freight bill. If concealed damage is discovered, then immediately call the delivering carrier for an inspection. The freight carrier's responsibility ceases 14 days after delivery. Damage reported after this point is the customer's responsibility. In fact, claims are rarely honored when damage is not reported within three days.

After inspection has been made, seal the shipping crate until installation.

Handle and store IRUS crates upright at all times.

Section 2 - Unpacking

Draper labels all IRUS crates "Optically coated side" and "Polished side".

Draper recommends you install the optically coated side facing the audience, unless there are compelling reasons to do otherwise (such as high risk of abuse from audience side). Position crate accordingly before unpacking.

Use extreme care in unpacking to avoid scratching the optically coated surface. Do not use knives to remove wrapping. Wear soft cotton gloves when handling, or use a soft cloth or tissue paper as a hand pad.

Before removing wrapping, compare the size of the finished aperture with the IRUS panel.

The installer assumes all risks if IRUS rear projection screens are cut or altered in the field. Any alteration of an IRUS after it leaves our plant automatically voids the product warranty.

Section 3 - Installation

Make sure all other aspects of construction have been completed before IRUS installation, including painting and cleanup. If you must do additional finish work after installation, cover screen with clear polyethylene sheeting until completion of work. (In a facility that is still under construction, more protection is warranted, such as a masonite or homocel covering. Hard coverings must not be allowed to contact coated surface directly.)

Experienced glaziers should perform installation in accordance with standard glazing practices for indoor installation. Use suction cups and other handling equipment on the polished (uncoated) side only.

Take care at all times not to scratch or mar the optical coating.

Section 4 - Cleanup

Remove any dust from IRUS surface with a soft clean cloth. Remove soil marks cleaned with a soft, dry cloth. Do not use solvent or abrasives. Do not use Armor All®. Contact Draper for stronger cleaning needs.

Section 5 - Measuring Instructions

Draper recommends that IRUS orders not be released for manufacture until you take confirming field measurements. Measurements of finished openings or frames should be accurate to the nearest 1 1/16" (27mm) for satisfactory fit. Dimensions of IRUS panel or Cineframe should be specified a minimum of 3/8" (10mm) smaller in each dimension than finished opening or frame I.D., which allows just 3/16" (5mm) clearance on each side for safe insertion.

Be sure to allow sufficient time for manufacture after release of order.

Draper cuts and coats IRUS rear projection screens to your specification and certain larger sizes require substantial lead time. Check with your Draper dealer for accurate information concerning your specific requirement.

Section 6 - Ordering Instructions

In order to fill your order properly, we must have the following information:

1. Shipping address, markings and instructions (if needed)
2. Desired delivery date
3. Quantity
4. Exact dimensions.
5. Cineframe (if required): System number, finish, and overall dimensions.

Example: 1 — IRUS Rear Projection Screen

1/4" x 74" H x 98" W overall size

Height and width dimension should be the overall size of the panel or frame (specify which), not opening size or image size.

Section 7 - Screen Orientation

Rear projection screens are most frequently mounted with the optically coated side toward the audience, as this greatly reduces glare and reflections from ambient light in the audience area. Draper recommends installing optically coated side facing the audience. However, take care when installing screens to protect the coated surface from accidental damage or abuse. If screen must be installed with polished side toward audience, all ambient light will need to be eliminated from audience area.

If you have any difficulties installing or servicing your IRUS Rear Projection Screen, call your dealer or Draper, Inc.



Rigid rear screen installation costs and problems are virtually eliminated with factory-installed Cineframes. Simply place the screen in the finished wall opening, shim into position, and trim as desired. Draper suggests rough opening be at least $\frac{3}{8}$ " (10mm) larger than overall frame size that fits within the opening. Four styles available. All are extruded of 6063-T5 alloy anodized aluminum.

System 400

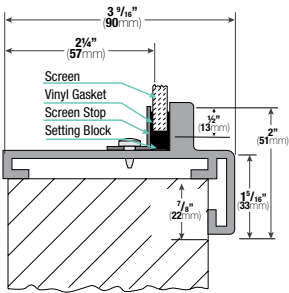

System 400 simplifies your installation. Cut a rough opening $\frac{3}{8}$ " (10mm) larger than the overall frame size*, slide the screen in and bolt into place. No finish carpentry required. System 400 has a $1\frac{3}{4}$ " (44mm) wide dress trim that hides the opening. The audience only sees an attractive frame around a rear screen. Suitable for all Cineglass and Cineplex thicknesses and sizes (see front page for more details). Black finish. Weighs 1 lb., 7 oz. (0.65kg) per lineal foot (30cm). Reduces clear image area by 1" (2.5cm) in each dimension.

*Add $2\frac{5}{8}$ " (67mm) to viewable area of screen to calculate the overall size of that portion of the System 400 Cineframe which is within the rough opening.

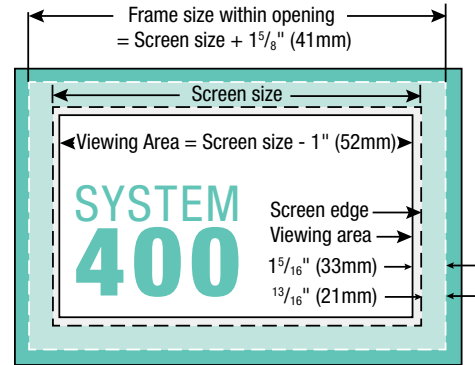

System 350

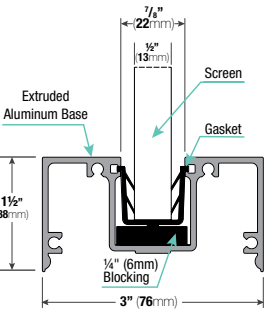

Adds 3" (76mm) to viewable area of screen. Cut a rough opening $\frac{3}{8}$ " (10mm) larger than the overall frame size. Suitable for Cinescreens in $\frac{1}{2}$ " (13mm) thickness in all sizes (see front page for more details). Black finish. Weighs 1 lb., 5 oz. (0.59kg) per lineal foot (30cm).

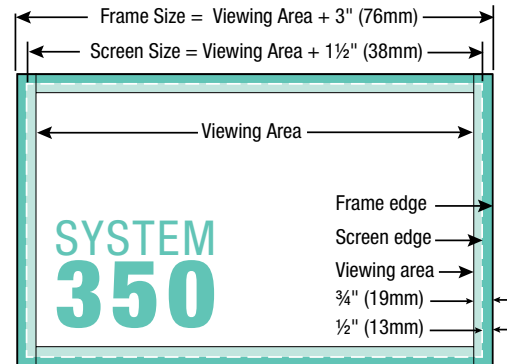

System 200

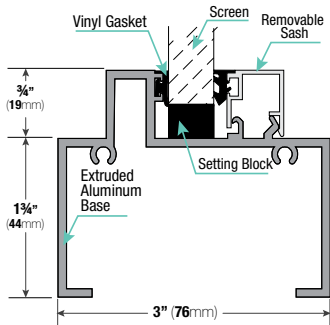

Adds 5" (127mm) to viewable area of screen. Cut a rough opening $\frac{3}{8}$ " (10mm) larger than the overall frame size. Suitable for Cineglass in $\frac{1}{4}$ " (6mm) or $\frac{3}{8}$ " (10mm) thickness through 8' x 10' (2.4x3m), and Cineplex in $\frac{1}{4}$ " (6mm) or $\frac{3}{8}$ " (10mm) thickness in all sizes (see front page for more details). Black finish. Weighs 1 lb. (0.45kg) per lineal foot (30cm).

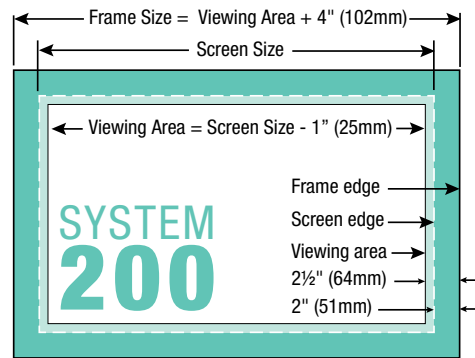

VersaRoll

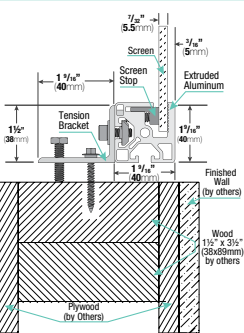

Adds $3\frac{1}{8}$ " (7.9cm) to the viewable area of screen. Cut a rough opening 1" (25mm) larger than overall frame size suspended within opening if a flat screen. Suitable for Cineplex in $\frac{1}{8}$ " (3mm), $\frac{3}{16}$ " (5mm) or $\frac{1}{4}$ " (6mm) thickness. Black or clear anodized available.

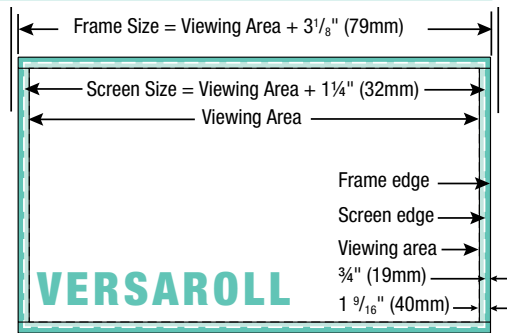

Framing Systems by Others

Field-installed framing systems may be used and provided by others. Steel, wood and aluminum are all suitable materials. It is essential that any Cinescreen be fully isolated from load bearing, and a minimum of $\frac{3}{8}$ " (10mm) clearance must be allowed for insertion into the rough opening. Additionally, Cineplex framing systems should allow for the acrylic expansion-contraction factor. Consult a qualified glazing specialist when planning any Cinescreen field installation.

Important: Optically coated side normally installed facing the audience.