

DETAIL A
SCALE 0.18 : 1

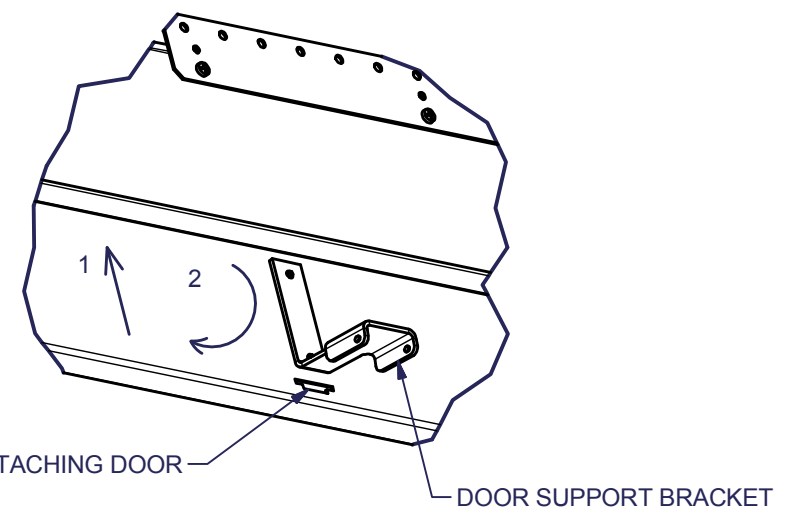
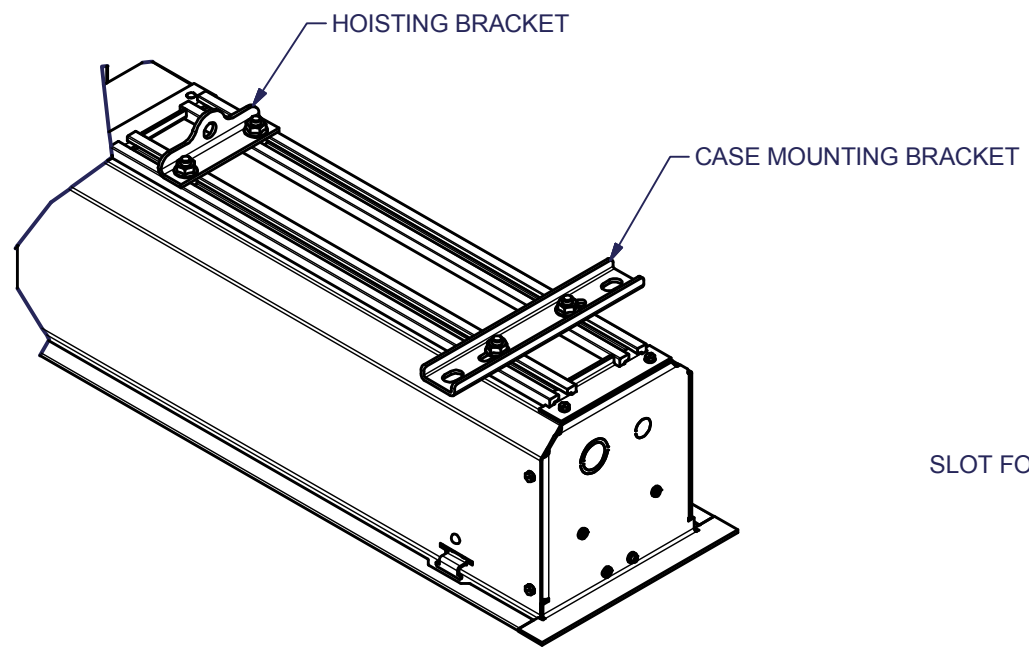
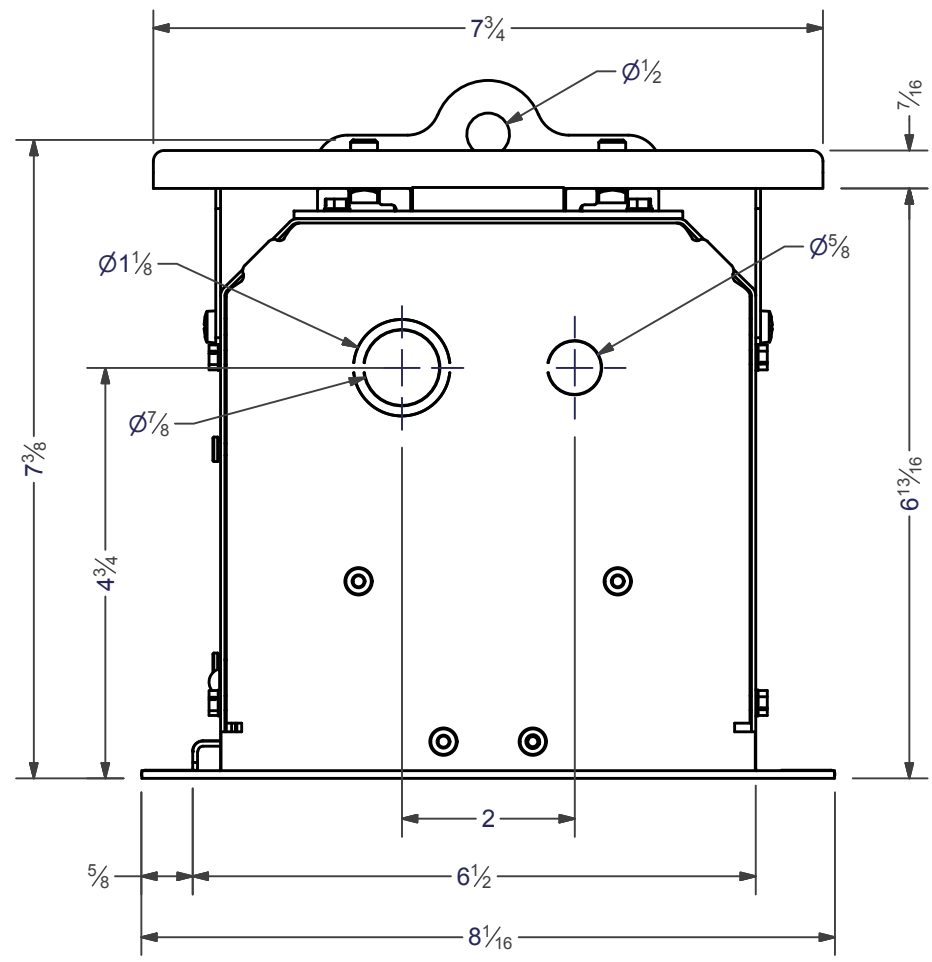
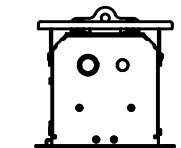
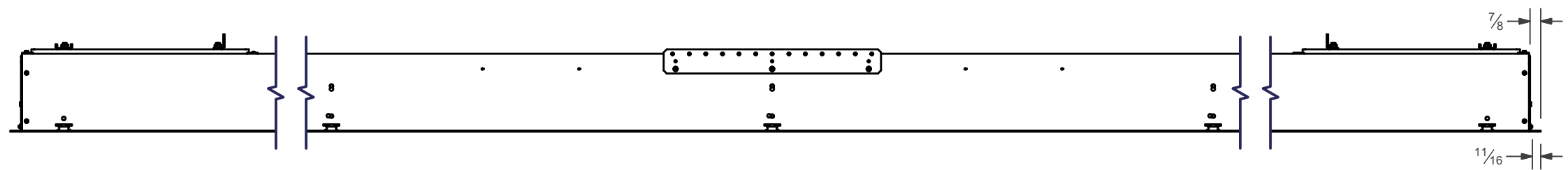

ATTACHING BRACKETS
STEP 1. Insert Pin in Top Slot and Push Up
STEP 2. Rotate Bracket CW to Lock Bracket In Place

<p>TOLERANCES UNLESS NOTED</p> <p>2 PLC. DECIMAL: ±.01" 3 PLC. DECIMAL: ±.005" ANGULAR: ±1° FRACTIONAL: ±1/32"</p>	DESIGNED BY: senochs	7/23/2013
	DRAWN BY: senochs	12/5/2014
	CHECKED BY:	
	MFG APPD BY:	
	ENG APPD BY:	
<p>PROPRIETARY DRAWING NOTICE: THIS DOCUMENT CONTAINS CONFIDENTIAL, PROPRIETARY INFORMATION OF DRAPER, INC., IS THE PROPERTY OF DRAPER, INC., AND MUST BE RETURNED UPON REQUEST. NEITHER RECEIPT NOR POSSESSION THEREOF CONFERS ANY RIGHT TO OWN, REPRODUCE, USE, OR DISCLOSE IN WHOLE OR IN PART, ANY SUCH INFORMATION WITHOUT WRITTEN AUTHORIZATION FROM DRAPER, INC.</p>		

		DRAPER, INC. 411 S. PEARL STREET SPICELAND, INDIANA 47385-0425 www.draperinc.com	
		TITLE: ACCESS STEEL LARGE CASE DIMENSIONS	
MATERIAL:			
PAPER SIZE: B	FINISH:		
SCALE: NONE	REV:	SHEET: 8	DWG NO. - PART NO.
	OF:	8	