

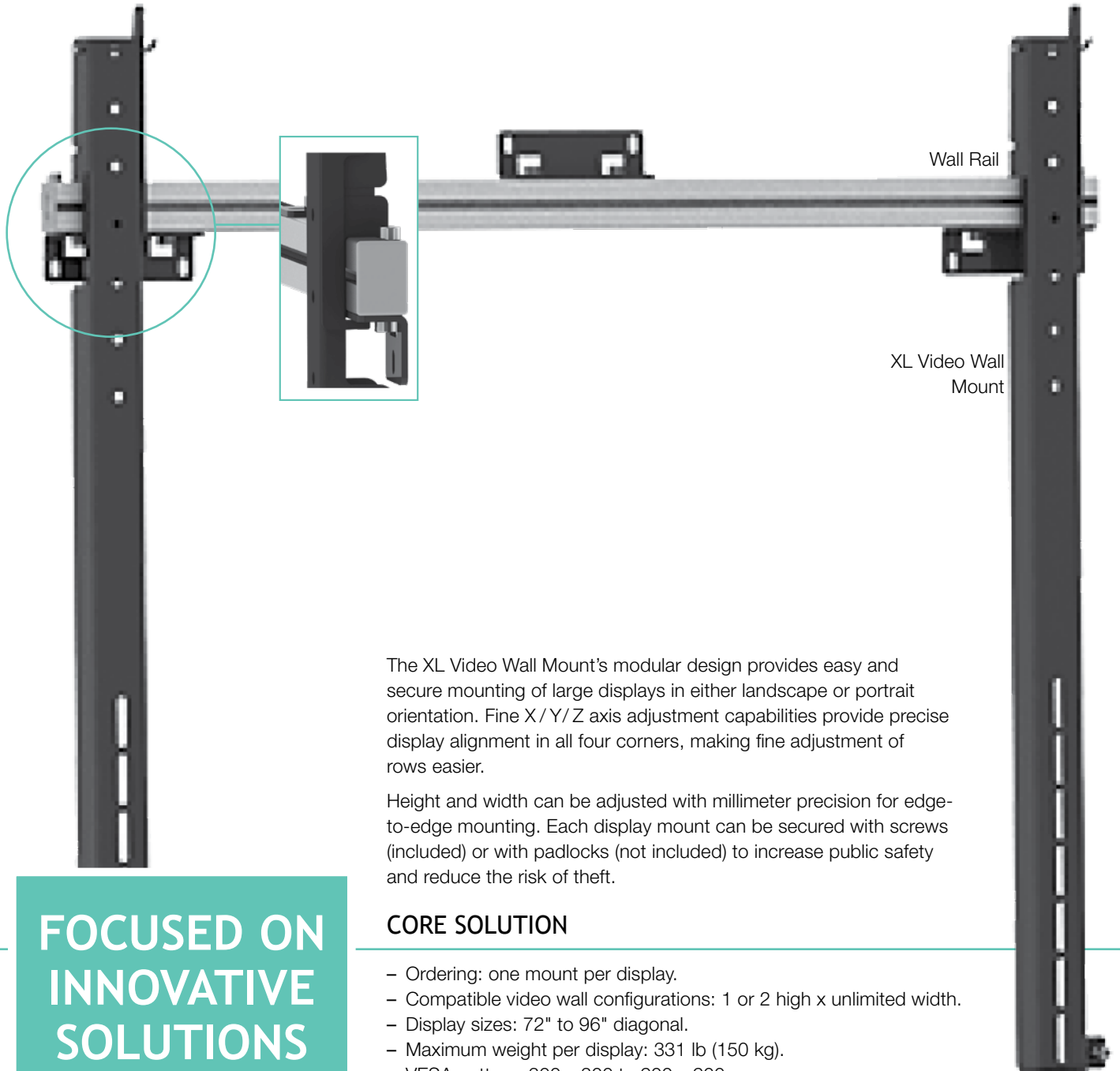

XL VIDEO WALL MOUNT



**FOCUSED ON
INNOVATIVE
SOLUTIONS**

The XL Video Wall Mount's modular design provides easy and secure mounting of large displays in either landscape or portrait orientation. Fine X/Y/Z axis adjustment capabilities provide precise display alignment in all four corners, making fine adjustment of rows easier.

Height and width can be adjusted with millimeter precision for edge-to-edge mounting. Each display mount can be secured with screws (included) or with padlocks (not included) to increase public safety and reduce the risk of theft.

CORE SOLUTION

- Ordering: one mount per display.
- Compatible video wall configurations: 1 or 2 high x unlimited width.
- Display sizes: 72" to 96" diagonal.
- Maximum weight per display: 331 lb (150 kg).
- VESA pattern: 300 x 300 to 900 x 900.
- Depth of mount: 1.85" (47 mm).
- Finish: anodized aluminum and black powder coat.
- Included hardware: one wall rail with attachment hardware, two vertical hanging brackets, one universal display attachment hardware, and two endcaps.