

# MULTI DISPLAY WALL RAIL

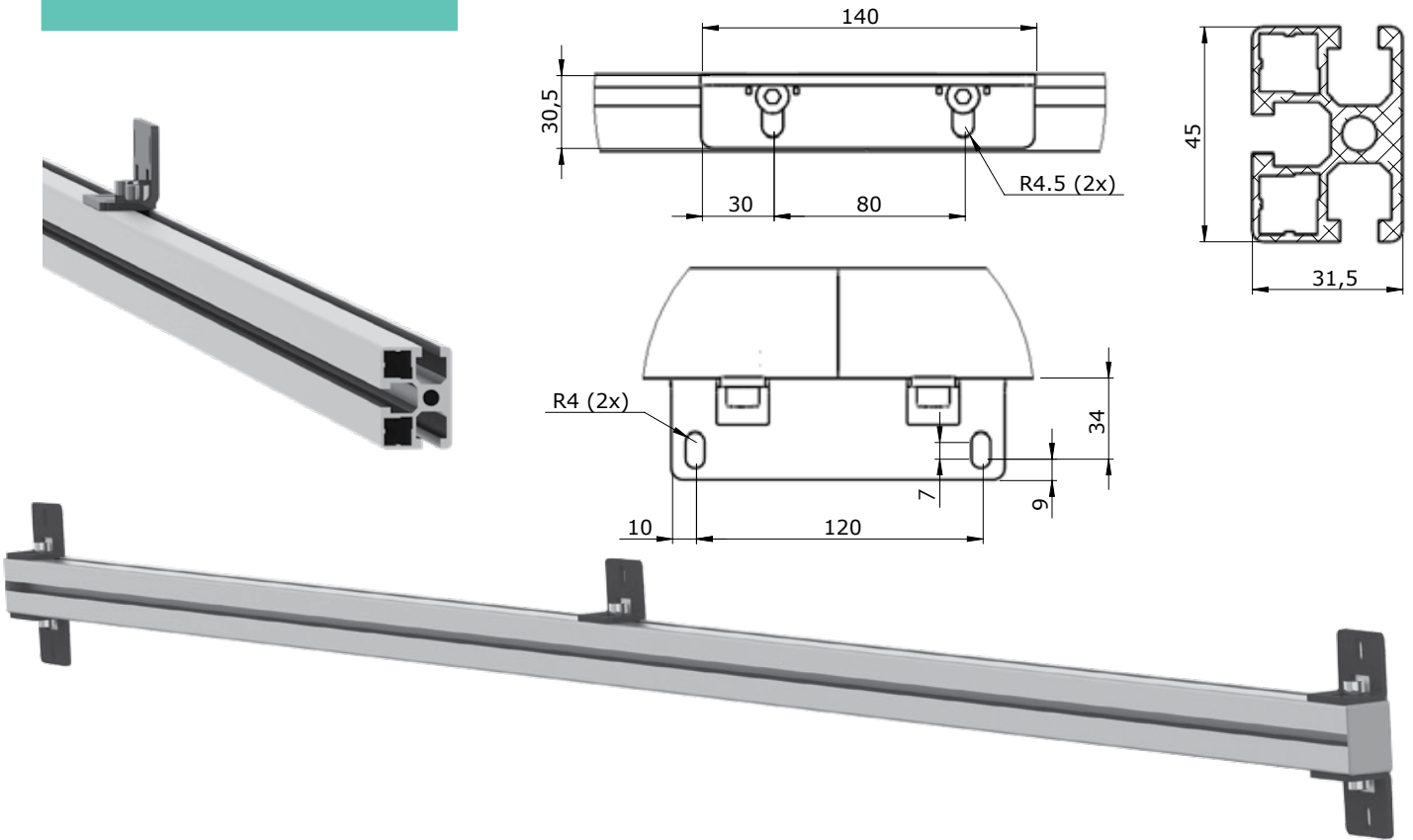

The Multi Display Wall Rail simplifies mounting by utilizing one 78.75" (2000 mm) long rail instead of multiple rails for extra fast and accurate mounting. This provides a single installation with a continuous level mounting point for all displays in the row. One long rail allows for easier leveling of multiple displays within a row.

These aluminum wall rails can be cut to desired length in the field and combined. Attractive endcaps provide a nice finish. The Multi Display Wall Rail can be used with any of the video wall mount series.

**FOCUSED ON  
INNOVATIVE  
SOLUTIONS**

## CORE SOLUTION

- Length: 78.75" (2000 mm) long.
- Maximum weight per display: 331 lbs. (150 kg).
- Included hardware: one wall rail with attachment hardware and two endcaps.
- Aluminum finish.