

4

3

2

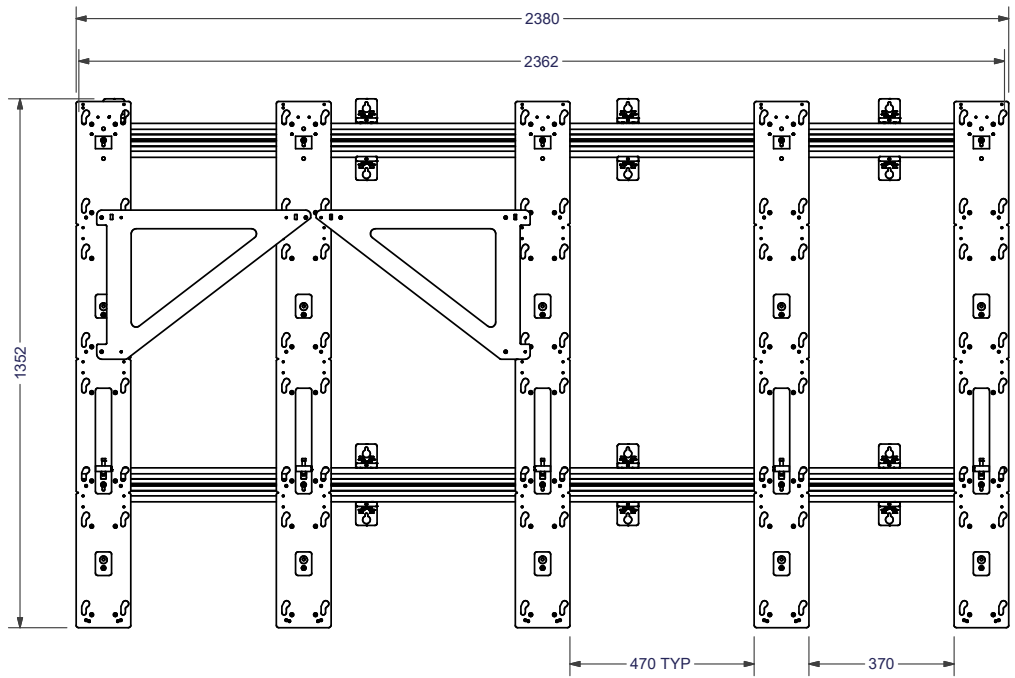

1

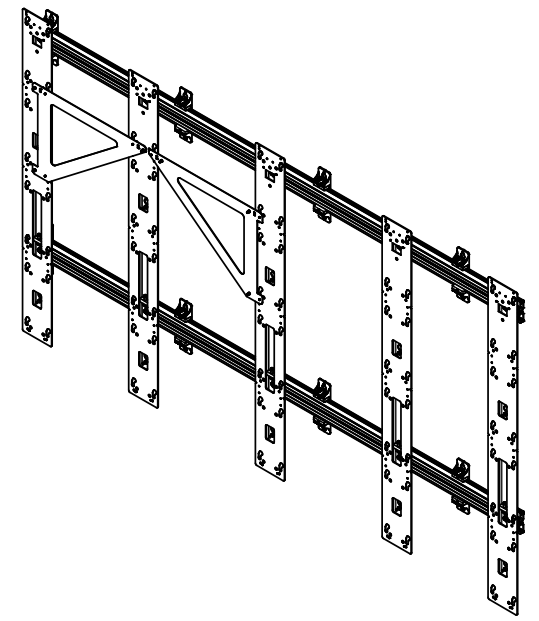

FRAME ONLY



PROPRIETARY DRAWING NOTICE: THIS DOCUMENT CONTAINS CONFIDENTIAL, PROPRIETARY INFORMATION OF DRAPER, INC., IS THE PROPERTY OF DRAPER, INC., AND MUST BE RETURNED UPON REQUEST. NEITHER RECEIPT NOR POSSESSION THEREOF CONFERS ANY RIGHT TO OWN, REPRODUCE, USE, OR DISCLOSE IN WHOLE OR IN PART, ANY SUCH INFORMATION WITHOUT WRITTEN AUTHORIZATION FROM DRAPER, INC.

TOLERANCES UNLESS NOTED	DESIGNED BY: senochs	12/17/2019	 DRAPER, INC. 411 S. PEARL ST. SPICELAND, IN 47385 www.draperinc.com
	DRAWN BY: Adam Timmins	11/6/2020	
	CHECKED BY:		
	MATERIAL:		
FINISH:			TITLE: FOUNDATION 4 X 4 ABSEN ACCLAIM AND ACCLAIM PLUS MOUNT WITHOUT TRIM
 DO NOT SCALE			DWG SIZE : REV: SHEET: DWG NO. : B 000 OF: 1 2 302201

000	REV	DATE	ECO	BY	DESCRIPTION
REVISION HISTORY					

4

3

2

1

4

3

2

1

B

B

A

A

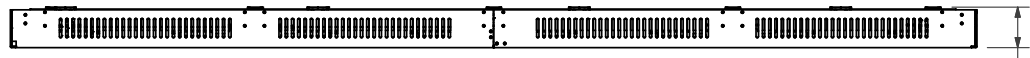

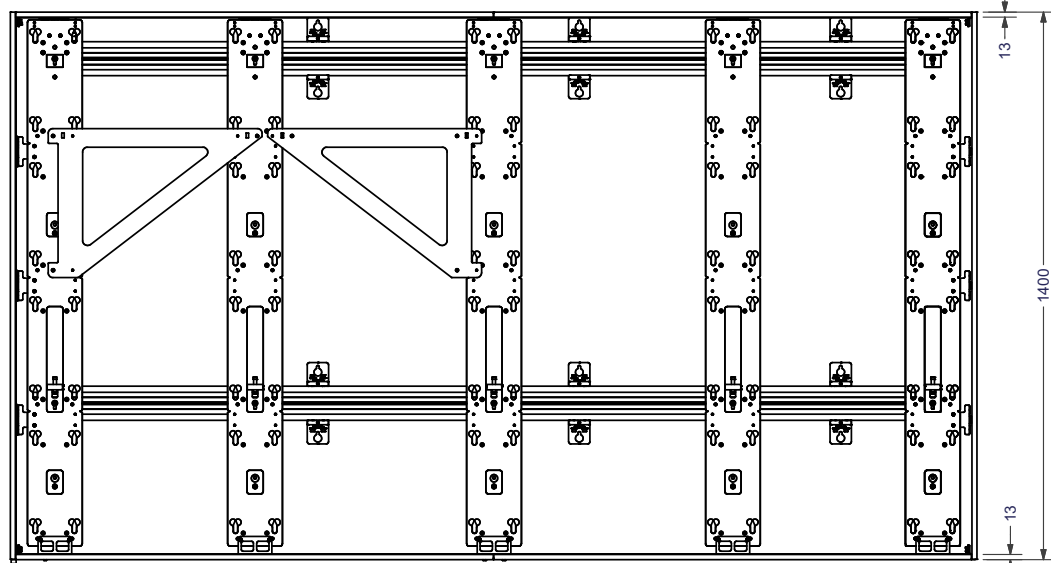

103 MIN ACCLAIM PLUS
119 MIN ACCLAIM

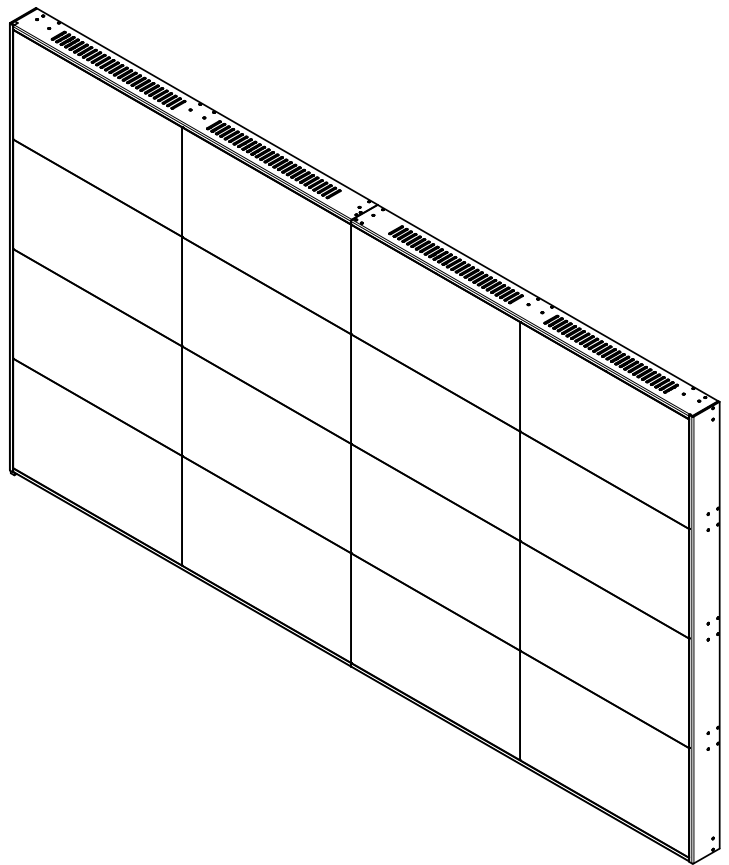

FRAME AND TRIM



PROPRIETARY DRAWING NOTICE: THIS DOCUMENT CONTAINS CONFIDENTIAL, PROPRIETARY INFORMATION OF DRAPER, INC., IS THE PROPERTY OF DRAPER, INC., AND MUST BE RETURNED UPON REQUEST. NEITHER RECEIPT NOR POSSESSION THEREOF CONFERS ANY RIGHT TO OWN, REPRODUCE, USE, OR DISCLOSE IN WHOLE OR IN PART, ANY SUCH INFORMATION WITHOUT WRITTEN AUTHORIZATION FROM DRAPER, INC.

<p>TOLERANCES UNLESS NOTED</p>	DESIGNED BY: senochs	12/17/2019	 <p>DRAPER, INC. 411 S. PEARL ST. SPICELAND, IN 47385 www.draperinc.com</p>			
	DRAWN BY: Adam Timmins	11/6/2020				
	CHECKED BY:					
MATERIAL:	TITLE: FOUNDATION 4 X 4 ABSEN ACCLAIM AND ACCLAIM PLUS MOUNT WITH TRIM					
 <p>DO NOT SCALE</p>	FINISH:	DWG SIZE: B	REV: 000	SHEET: 2	OF: 2	DWG NO.: 302251 FOR STANDARD ACCLAIM

4

3

2

1