

Installation Instructions

LCD Lift by Draper

⚠ Caution

- ① Read instructions completely before proceeding.
- ② Follow instructions carefully. Installation contrary to instructions invalidates warranty.
- ③ Do not obstruct operation of doors or universal (flat) closure with fingers or any object. Serious injury or damage could result.
- ④ It is not uncommon to overheat the motor during initial installation when setting limits. The motor is thermally protected and will stop working temporarily. DO NOT physically pull the unit down when this occurs. Once it has cooled to a safe temperature, it will begin operating again.
- ⑤ LCD Lift is designed to accommodate ceiling suspended equipment. Equipment should not be allowed to rest on doors during operation.
- ⑥ Unit must be installed level (use a carpenter's level).
- ⑦ Perform Pre-Installation Testing Procedures before beginning installation.

NOTE: Unit has been thoroughly inspected and tested at factory and found to be operating properly prior to shipment.

Planning

- ① Based on screen location and projector specifications, determine proper position for projector installation.
- ② Confirm that there is adequate space available above the ceiling: 19½" for LCD Lift A; 24½" for LCD Lift B.
- ③ Arrange to provide service access to electrical control box on lift.

As Soon as LCD Lift Arrives:

- ① Open carton and inspect for damage.
- ② Locate the following parts:
 - A. The unit itself
 - B. Bomb bay doors or optional ceiling closure
 - C. Controls
- ③ Follow Pre-Installation Testing Procedure.

Pre-Installation Testing Instructions

This LCD Lift was extensively tested and in perfect condition when it left our plant. To make sure that it arrived in the same condition, please use the following procedure to test the unit prior to installation. Draper does not accept back charges for labor. Make sure that this unit is operating satisfactorily before installation.

Danger! The traveling pan can exert over 65 pounds of force. Do not insert any body parts or other objects into this unit while power is connected.

- ① Remove the unit from the outer carton.
- ② Remove the cover of the electrical box.
- ③ Pre-wire supplied controls and make sure that the switch is in the off position and plug the unit into a 110-120V AC outlet. **Caution: do not touch any exposed wires while the unit is plugged in.**
- ④ Inside the electrical box you will find that a temporary plug has been connected to the terminal board. Extend this plug from the box. Replace the electrical box cover so that the cover is held loosely (so as not to crush the wires) in place.
- ⑤ Use the switch to move the traveling pan up and down. Removal of the access panel will allow the observation of this movement. The unit will stop automatically when it reaches the fully up or fully down position.
- ⑥ Cycle the unit in both directions until you are satisfied the unit is operating properly. If for any reason the unit does not seem to operate properly, call Draper, Inc. 765/987-7999. Do not proceed with installation.

- ⑦ If the unit has been ordered with the remote control option, again verify operation of the unit by use of the hand held transmitter. If for any reason the unit does not operate properly, call Draper, Inc., 765/987-7999. Do not proceed with installation.
- ⑧ If the unit is operating satisfactorily, remove and discard the temporary plug.
- ⑨ Disconnect the switch at the terminal board (terminals #1, #3, and #7). Do not discard this switch. It is to be used as the wall switch.
- ⑩ Replace the cover on the electrical box.
- ⑪ Proceed with the installation, referring to instructions supplied.

Hangng Unit

The LCD Lift may be installed in a variety of ways. Typically, it is recessed above the ceiling and supported by four ½" threaded mounting rods. The bottom of the LCD Lift should be recessed approximately 1½" above the finished ceiling. The threaded rods should pass through mounting holes supplied in each corner and be secured by nuts above and below (see Fig. 1). The unit should then be guy wired or blocked to prevent swinging. All installations should observe the following guidelines:

- ① Installer must ensure that all fasteners and supports are of adequate strength to securely support LCD Lift and projector.
- ② Fastening methods must be suitable for mounting surface, and anchored so vibrations or abusive pulling will not weaken installation.

⚠ Caution: DO NOT hang from, "ride" or pull down on the unit. This could create a failure and cause damage and/or injury.

- ③ Unit should be level, with weight shared more or less equally by all four threaded mounting rods.
- ④ Bottom of unit must be unobstructed after installation. 12" minimum clearance is required below LCD Lift A; 14½" below LCD Lift B.
- ⑤ Access should be provided to electrical control box in case service is required.
- ⑥ Do not use unit to support adjacent ceiling, light fixtures, etc.
- ⑦ Do not complete the ceiling below unit until electrical connections have been completed and unit has been operated successfully.
- ⑧ We recommend that safety cables be attached to the LCD Lift for added security.

LCD Lift Dimensions

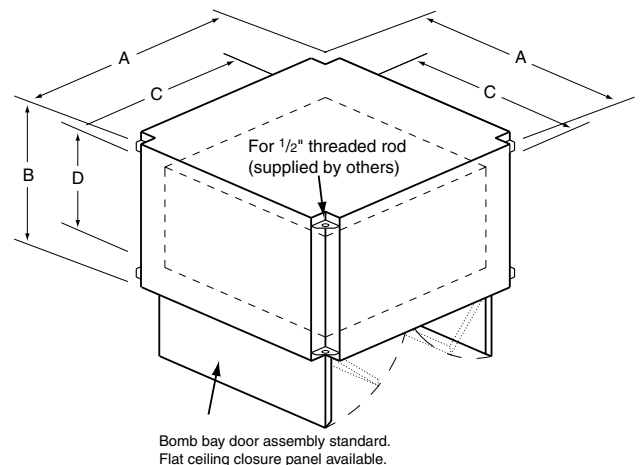

	A	B*	C	D	Travel	Capacity
LCD Lift A	24"	17¾"	18"	11"	11½"	65 lbs.
LCD Lift B	29"	22¾"	23"	16"	16½"	65 lbs.

* Ceiling Closure Panel adds ¾" to this dimension

Figure 1

DRAPER

411 S. Pearl St., Spiceland, IN 47385 USA ■ 765-987-7999
www.draperinc.com ■ fax 765-987-7142

Copyright © 2015 Draper Inc. Form LCDLift_Inst15 Printed in U.S.A.

If you encounter difficulties installing or servicing your LCD Lift, call your dealer or Draper, Inc., Spiceland, Ind., (765) 987-7999; or fax (765) 987-7142.

Electrical Connections

Unit operates on 110-120V AC, 60 Hz. current. Opening electrical control box exposes terminals for field connections. Unit is shipped with internal wiring complete and control switch(es) boxed. Wire connecting unit to switch(es) and to power supply should be furnished by installer. Connections should be made in accordance with wiring diagram, and wiring should comply with national and local electrical codes. **All operating switches should be "off" before power is connected.** LCD Lift should be operated and checked prior to installing bomb bay doors, universal (flat) ceiling closure or projector.

Operation

When unit is first operated, be cautious. If doors or closure panel do not begin to open momentarily when switch is flipped "down", return switch to "off" and free doors and/or recheck electrical connections before proceeding. Cycle unit down and up several times to confirm satisfactory operation.

Single Station Control—Moving 3-position switch to "down" position will start projector and bomb bay doors down. Moving switch to "up" will start projector and doors up. When projector is fully down or fully up, it will automatically be stopped by factory set limit switches. Whenever switch is placed in center "off" position, operation will stop.

Optional Multiple Station Control—Each switching station has a three-button switch with "up", "down", and "off" buttons. Unit starts up or down when appropriate button is pressed, and may be stopped by pressing "off" button. Factory set limit switches stop unit automatically when projector is fully up or fully down.

Optional Key Operated Switch—If ordered, a single station, key-operated three position (up/off/down) switch is available for this unit.

Optional Video Interface Control—Optional control device allows the LCD Lift switch to control the operation of a Draper motorized projection screen via relay.

Optional Infrared or Radio Frequency Remote Control—A three-button transmitter is provided, with "up", "down", and "stop" buttons. Unit starts up or down when appropriate button is pressed, and may be stopped by pressing the "off" button. Factory set limit switches stop unit automatically when projector is fully up or fully down.

Optional RS232/Ethernet—Serial communication and network communication optionally available with wall switches, RF or IR remote.

LCD Lift—Required Space Above Ceiling

	LCD Lift A	LCD Lift B
Bomb Bay Closure	18 ³ / ₄ "	23 ³ / ₄ "
Universal (Flat) Ceiling Closure	19 ¹ / ₂ "	24 ¹ / ₂ "

Installing Bomb Bay Door Closure

- Attach closure to LCD Lift frame with factory supplied hardware. Make sure the blue dot on ring holding the bomb bay doors lines up with the blue dot on the unit. (This will ensure that your doors will open down to the sides, and not to the front and back, which will block the projector's light path.) Bomb bay doors should be hanging straight down.
- Lower unit until traveling pan is approximately 4" above its lowest position.
- Install 1/2" Chase Nipples (included) before threading bead chain.
- Install supplied ball chain to connectors attached to the eye bolts threaded into angles on traveling pan (See Fig. 2).
- Install ball chain to connectors attached to bomb bay doors.
- Raise unit to highest position. Doors should close completely.
- If the doors do not close completely, lower unit and adjust the eye bolts until doors close completely.
- Once "closed" position has been accomplished, lock eye bolts into place with hex jam nuts.
- Adjust the LCD Lift to the height of the finished ceiling.

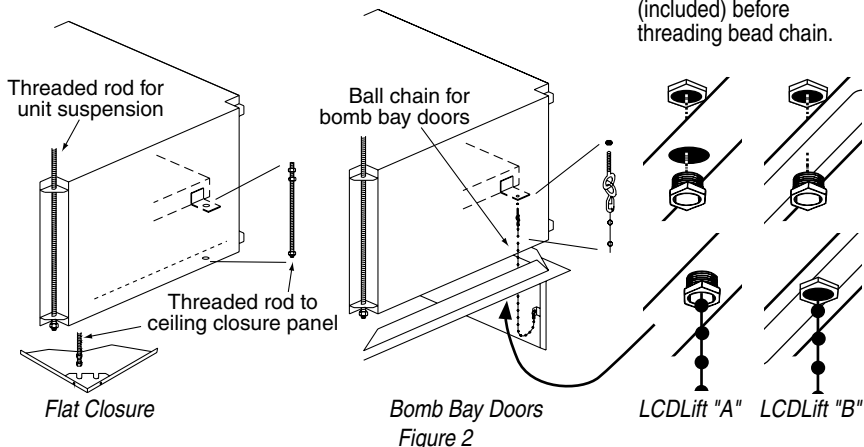

Installing Optional Ceiling Closure

If your LCD Lift is equipped with an optional ceiling closure system, it can be used as is, or in conjunction with a piece of existing ceiling tile.

- If installing with ceiling tile, you may need to cut tile so that its overall dimensions are the same as (or slightly less than) the closure panel. Place tile into trim frame. Lay closure panel on top (back side) of ceiling tile, and tighten screws to hold in place.
- If installing large closure, attach brackets to bottom of projector plate (see drawing at right).
- Attach 5/16" threaded rods to slots in projector plate or brackets.
- Run unit "up" until bottom pan stops at highest position. Mark position on 5/16" rods even with ceiling level and cut rods to length (removing from pan if convenient).
- Run unit "down" until bottom pan stops at "show" position.
- Attach closure to lower end of 5/16" rods by slipping into four corner slots and secure with nuts above and below slots.
- Run unit "up" again to highest position. Measure distance by which panel fails to reach required "closed" height for surrounding ceiling.
- Run unit "down" then re-adjust mounting of 5/16" rods in traveling grid to raise panel required distance.

Caution: Make sure nuts are completely tightened.

Test unit operation to confirm that panel will stop in closed position just before touching ceiling.

Caution: DO NOT hang from, "ride" or pull down on the unit. This could create a failure and cause damage and/or injury.

NOTE: Immediately upon completion of the surrounding ceiling, unit should be operated to confirm that optional ceiling closure panel stops just short of touching ceiling in closed position.

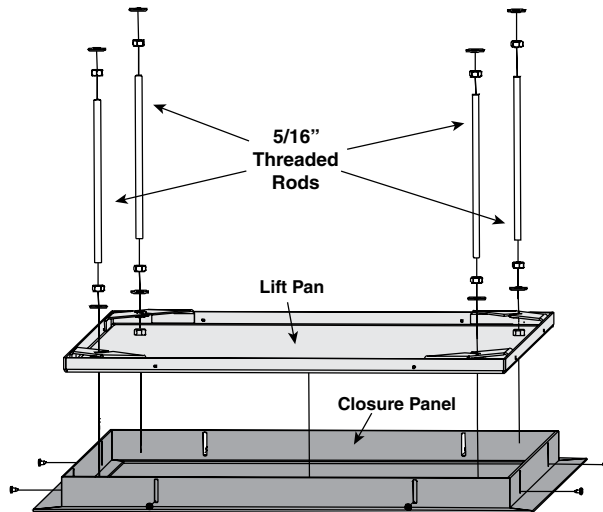

For Additional Safety:

- Be sure the nuts that attach the threaded rods to the closure panel are tight.
- Wrap a plastic wire tie around the mounting tab and the threaded rod at all four corners of the closure panel (see drawing).

Please Note: Do NOT use a paper-covered or similar wire tie—use only plastic wire ties for maximum safety.

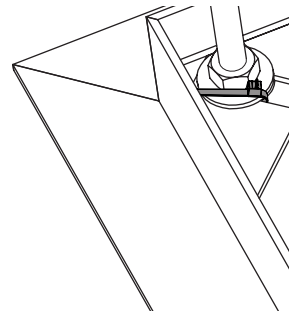

LCD Lift A with optional Closure Panel —Dims

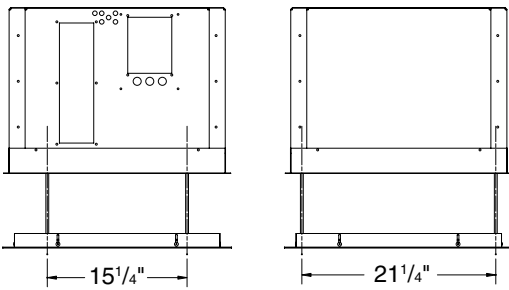

Installing Projector

Draper's optional Universal Projector Mount will hold up to 26 lbs.

- ① Bolt projector to Universal Mount Arms.
- ② Bolt Projector Pan with Universal Mount into place on bottom pan.
- ③ Use center nut and spring-loaded bolts to fine tune picture placement on screen.

If not using Draper's Universal Projector Mount, the video projector should be suspended from the traveling pan according to projector manufacturer's instructions, and using recommended standard ceiling mounting hardware ("Z" brackets are attached to bottom side of traveling pan for easier installation).

The LCD Lift has a grounded 110-120V AC, 60Hz outlet for projector power supply. Power is supplied to this outlet when unit is in "fully down" position. An

AC current sensor has been factory installed and will not allow the projector to rise into the LCD Lift until the projector has been cooled by its ventilation fan(s). When the fan(s) stop operating, the LCD Lift will raise the projector into its stored position.

Knockouts are provided for passage of signal and control cables.

Unit and projection system should be operated, checked and adjusted as necessary at this time.

Warning: Keep fingers and other objects away from automatic doors and traveling pan when unit is operating. Serious injury or damage could result.

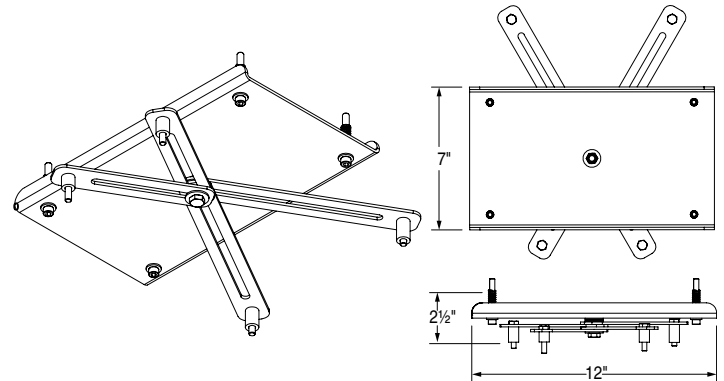

Wiring Diagram—
Single Station Control

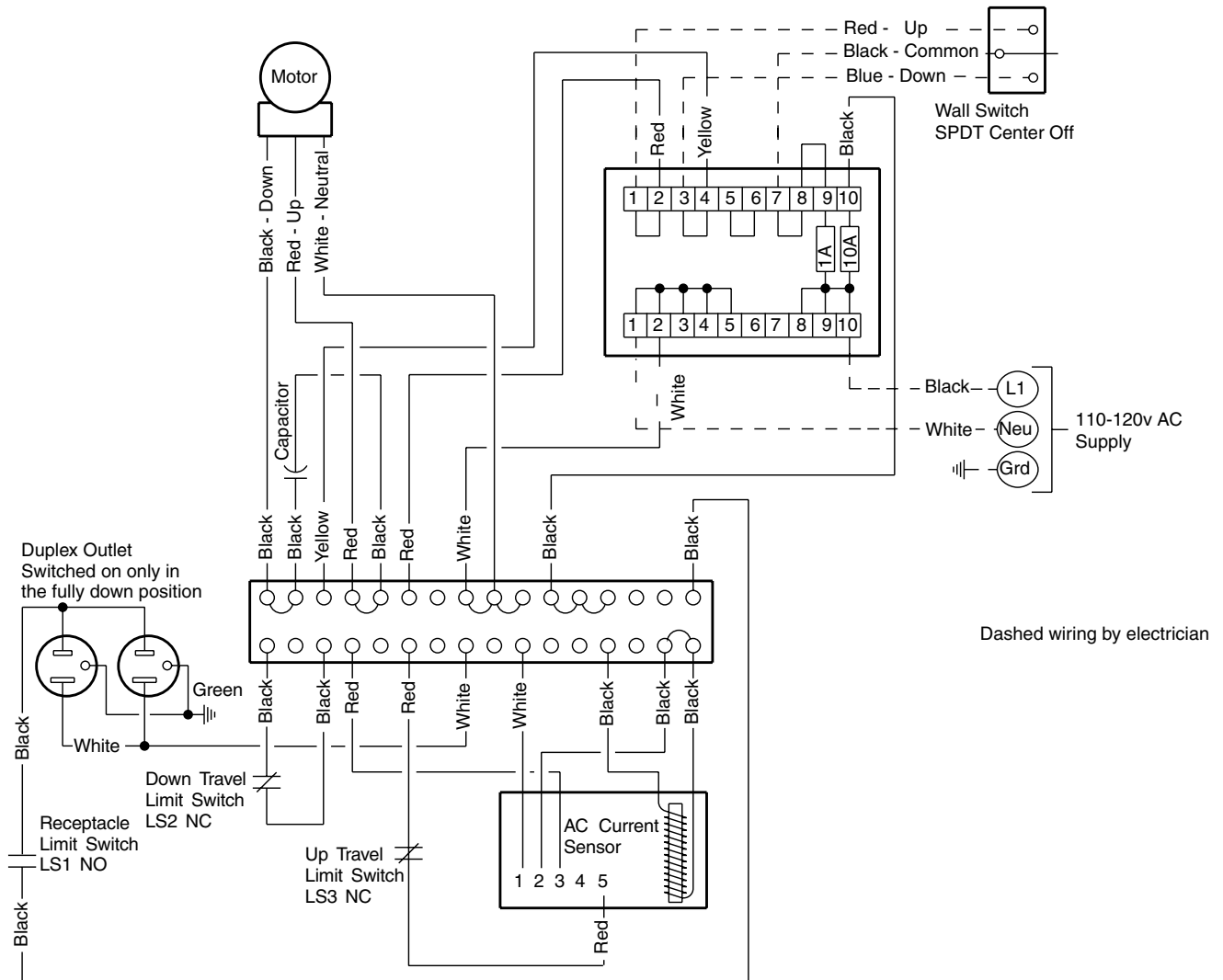

Wiring Diagram—
Optional Infrared and Radio Frequency Remote Control

Lift LVC — LCD Lift Wiring Diagram

