

ITEM	QTY	PART NUMBER	DESCRIPTION
1	4	C044.193SA	Panel, B Plenum Side
2	4	C044.191SA	Panel, B Plenum End
3	2	C044.192SA	Panel, B Plenum Middle Side
4	2	C044.190SA	Panel, B Plenum Middle End
5	28	C020.325	SCREW, 8-32X3/8 TYPE 1 HWH
6	40	C018.051	NUT #8-32 ZINC HEX KEPS
7	12	C013.070	Washer, .188 I.D. x .5 O.D. x .07 TK Nylon Flat
8	26	C020.112	SCREW, 8-32X3/8 TYPE F HWH
9	1	C028.609.01SA	Frame, B Plenum
10	1	C095.130SA	COVER, B PLENUM
11	1	C028.610.07SA	Frame, B Trim Ring
12	4	C013.024	WASHER, 3/8" FLAT
13	4	C018.044	NUT 3/8-16 ZINC HEX KEPS
14	4	C020.313	SCREW 3/8-16x1" GR 5 ZINC HEX HEAD CAP

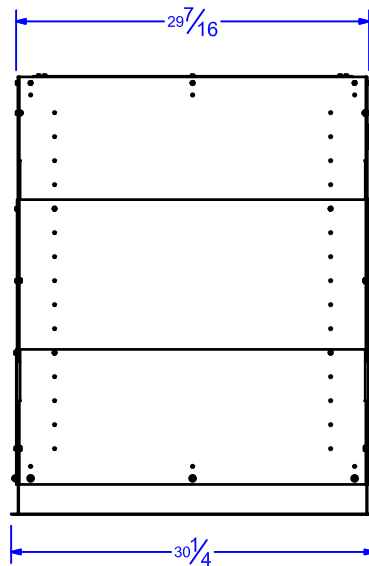
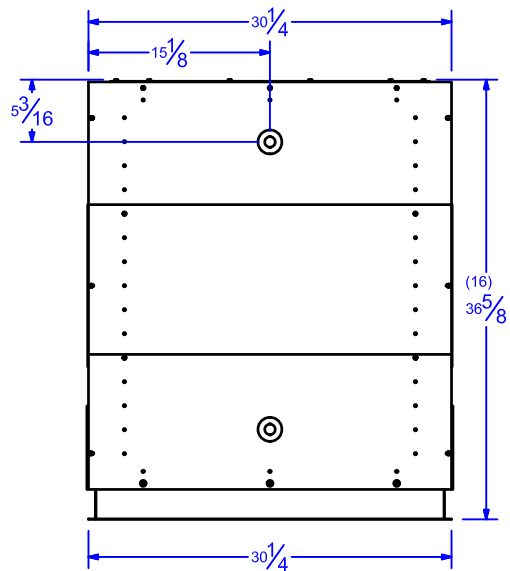
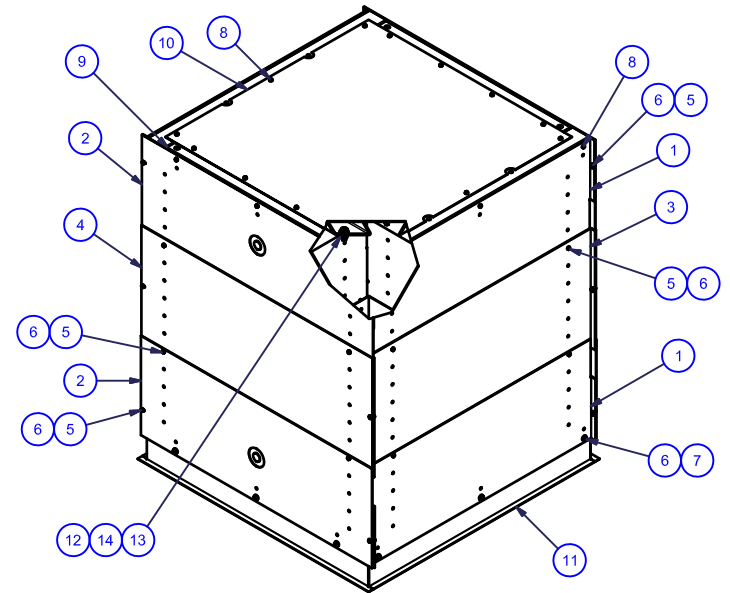
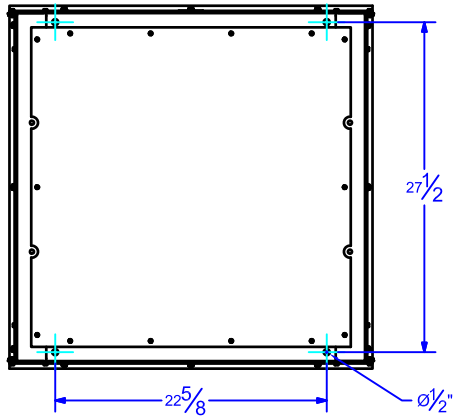

NOTES:
1. COMPRESSED HEIGHT = 16 in.

DRAPER DRAPER Inc.
411 S. Pearl St.
Spiceland, Indiana

Title
B Environmental Air Space

Sheet 1 of 1

Scale $3/4" = 1'$ Date 7/6/2012 Part NO. 300280