

EZ Fold® TB-25R

**Basketball Backstop—
Ceiling-Suspended, Compact
Rear-Folding, Rear-Braced**

by **DRAPER**

1. Superstructure supplied for existing conditions.
2. Contact Draper for Dimensions A & B.

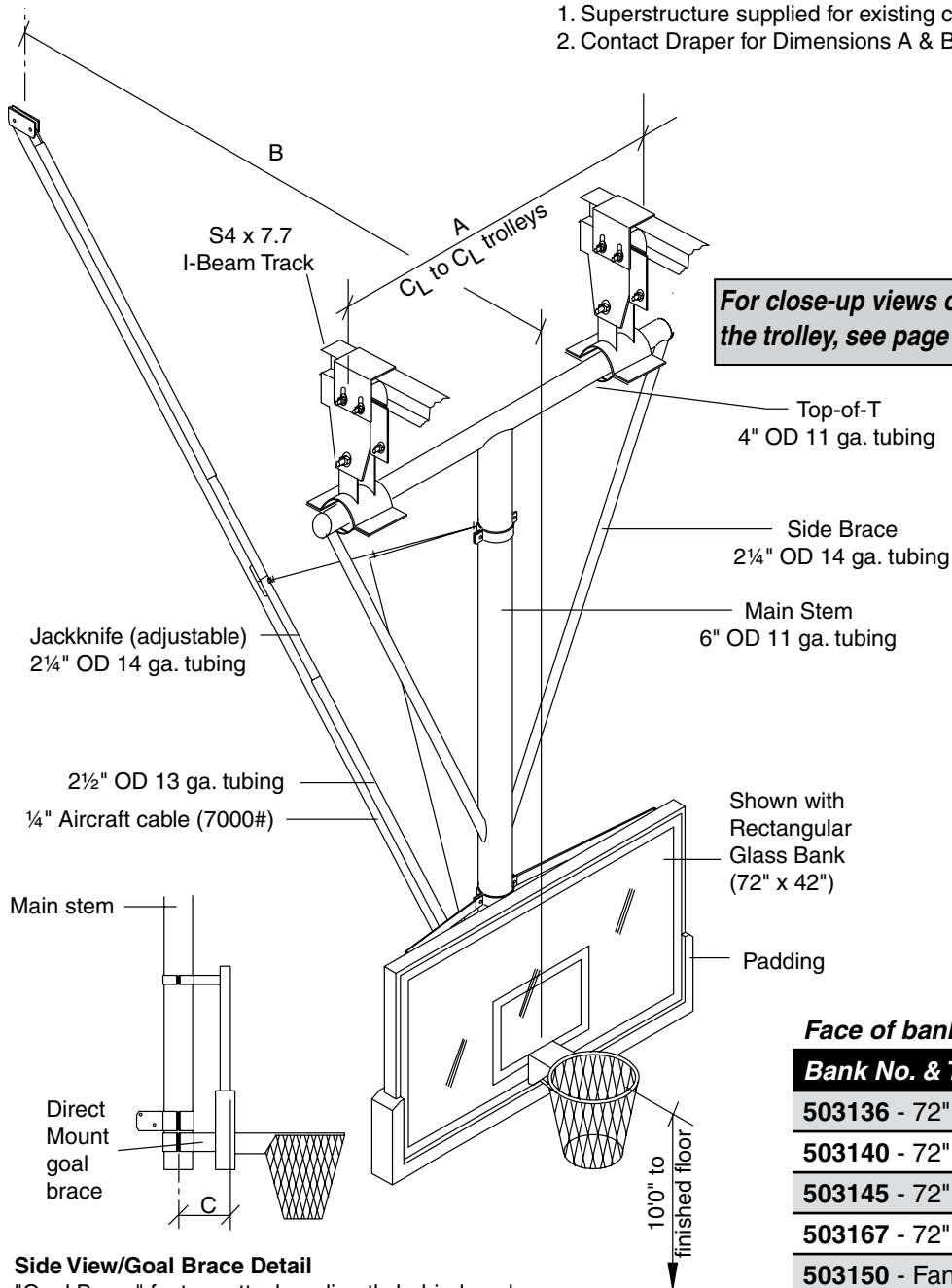

Side View/Goal Brace Detail

"Goal Brace" feature attaches directly behind goal mounting plate and directly to main stem of backstop, which eliminates strain on backboards.

Face of bank to CL of stem

Bank No. & Type	Dim C
503136 - 72" x 42" Rectangular Glass	11 ¼"
503140 - 72" x 42" Rectangular Wood	10 9/16"
503145 - 72" x 42" Rect. Fiberglass	10 ½"
503167 - 72" x 42" Rectangular Steel	10 ½"
503150 - Fan Glass	11"
503148 - Fan Fiberglass	10 ½"
503143 - Fan Aluminum	10 3/16"

Draper offers a 25-year limited warranty on the EZ Fold basketball backstop structure.

DRAPER

411 S. Pearl St., Spiceland, IN 47385 USA ■ 765-987-7999
www.draperinc.com ■ fax 765-987-7142
Copyright © 2015 Draper Inc. Form EZ-TB-25R_Sub15 Printed in U.S.A.

PROJECT: _____

ARCHITECT: _____

CONTRACTOR: _____

SUPPLIER: _____

DATE: _____ REVISED: _____

EZ Fold® TB-25R

**Basketball Backstop—Ceiling-Suspended,
Compact Rear-Folding, Rear-Braced**

Specifications—EZ Fold TB-25R

Ceiling-Suspended, Compact Rear-Folding Backstop (Under 28'4")

Product Description

Basketball backstop shall be the EZ FOLD Model TB-25R, ceiling-suspended, rear-fold by Draper, Inc. of Spiceland, IN.

Backstops shall be a welded together main frame constructed from steel mechanical tubing to form a rigid tetrahedral "T" design of back-to-back right triangles. The main stem (center strut) shall be 6" OD 11-gauge steel tubing, the top of the "T" shall be 4" OD 11-gauge steel tubing or 3½" ID pipe (above 32'5"), and the side braces shall be 2¼" OD 14-gauge steel tubing. Side braces shall join stem no higher than 4'6" above goal. The main stem shall be of sufficient length to allow plus or minus 6" height adjustment of either fan or rectangular banks.

The folding rear brace shall be jackknife type, fully adjustable, self-locking in the down position and constructed of 2½" OD 13-gauge (outer) steel tubing and 2¼" OD 14-gauge (inner) steel tubing.

The backstop shall be supported from 4" OD 11-gauge steel mechanical tubing (as shown on plans). Superstructure tubes shall be reinforced with bridging and/or bracing when truss centers exceed 10'0". Overhead structure to include two S4 X 7.7 I-Beam style tracks to which the top of the backstop T-frame is attached by means of two four wheeled heavy-duty trolley assemblies.

Pivot or hinge joint (pin height) for folding shall not exceed 15" from roof structure except when required by architect for coordination with other trades.

The main backstop frame shall pivot on 1¼" minimum solid steel shaft secured in a milled bearing hole in ½" minimum steel plate hangers to insure accurate positioning of bank. When backstop folds, trolleys shall move forward on tracks, allowing backstop to fold in a compact area.

The bank shall be attached to the 6" OD main stem by heavy-duty bank hangers. Hangers shall be constructed of 2¼" OD 14-gauge steel tubing and ¼" x 2" flat steel plate with slotted holes for lateral adjustment. All glass banks shall have one upper bank hanger and include a goal brace, which attaches directly to the goal mounting plate and directly to the 6" main stem of the backstop to eliminate any strain on the bank and help prevent glass breakage. This direct mount feature shall conform to NCAA recommendation No. 5-F (dated Mar. 1982) which states that the design of the unit shall transfer the load on the goal directly to the backboard support so as to minimize stress to the glass backboard.

Backstop shall have a black or white powder coat finish. Other colors optionally available: contact Draper for details.

Backstop is raised or lowered by a ¼" (6.35 mm) aircraft cable, certified minimum break strength of 7,000 pounds (3178 kg), operating over aluminum alloy sheaves with bronze oilite bearings that do not require lubrication.

Operation: Backstop shall be operated by 503085 motorized winches. For complete specifications, see separate sheet.

Options

Backstop can be provided with any of several different styles of backboards, goals and padding. Specify types desired. See separate sheets.

Accessories

Smart Gym Control System. For group control of Basketball Backstops with Electric Winches, Electric Divider Curtains, Electric Height Adjusters and other Auxiliary Devices. For complete specifications, see separate sheet.

503060 EZ Power Wireless Remote Control—For remote control operation of electric winch. For complete specifications, see separate sheet.

503029 Posilok™—Safety belt to automatically lock basketball backstop in position due to a sudden surge of speed created by a possible malfunction of the hoisting apparatus. For complete specifications, see separate sheet.

Height Adjusters (see separate sheets):

503093— For motorized 8'-10' Height Adjustment of rectangular bank.

503097— For motorized 8'-10' Height Adjustment of fan bank.

503095— For motorized 8'-10' Height Adjustment of rectangular bank with wireless remote control.

503098— For motorized 8'-10' Height Adjustment of fan bank with wireless remote control.

503096— For motorized 8'-10' Height Adjustment of rectangular bank with EZ Stick Power Wand.

503099— For motorized 8'-10' Height Adjustment of fan bank with EZ Stick Power Wand.

503092— For manual 8'-10' height adjustment of rectangular backboards.

503094— For manual 8'-10' height adjustment of fan backboards.

503003—Portable Height Adjuster Operator—Speed controlled battery powered operator for manual height adjusters. For complete specifications, see separate sheet.

LEED® Submittal Information

Credit	Measure	
MRc4 – Recycled Content	Post Consumer Average 51.21%	Post Industrial 0%
MRc5 – Regional Materials	Raw materials are commodity items from multiple sources so extraction point cannot be determined. Final Manufacturing/Assembly in Spiceland, IN 47385.	

