

Angled Coupler for 120V AC485 Motorized FlexShade®

SUBMITTAL
TECHNICAL INFO

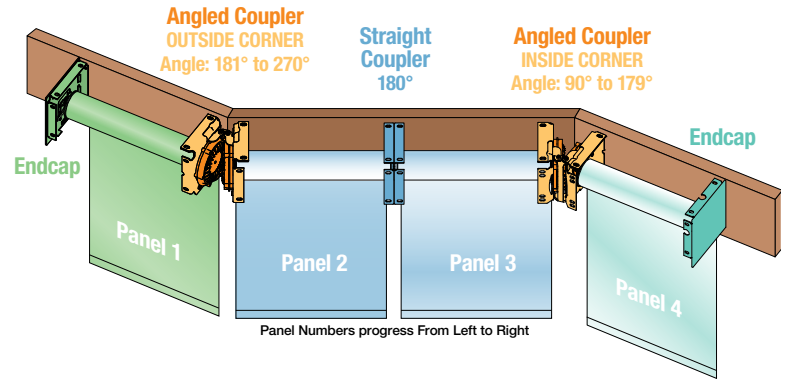

FLEXSHADE ANCOUP XMO

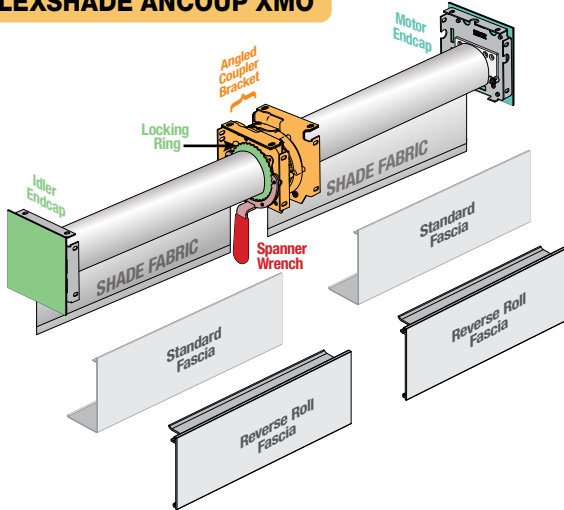

Please check all appropriate selections.

Select Shade Fabric

Fabric Series: _____

Color Name / Number: _____

Openness Factor: _____

Please visit [Draper Fabric Options](#) for fabric colors and specifications.

Select Fabric Orientation

- Standard Roll (from back of roller)
- Reverse Roll (from front of roller)

Select Slat Style

- Closed Pocket - 1" (25mm) Elliptical (standard)
- Open Pocket - 1" (25mm) Elliptical
- Small Rectangular Exposed Hem Bar
- Large Rectangular Exposed Hem Bar
- Round Exposed Hem Bar
- 5/8" (16mm) Tube
- None

Select Hardware Options

- Endcaps Only (Zinc only; plastic endcap cover to match hardware finish)
- Endcaps w/Fascia
- Surface Headbox (Fascia & Top/Back Cover)

Select Hardware Finish

- Clear Anodized (standard)
- White
- Bronze
- Black
- Ivory
- Custom (Contact Draper)

Number of Fabric Panels:

Minimum 2 Panels: 1 Idler Panel, 1 Motor Panel

Maximum 5 Panels: 1 Motor Panel, Up to 3 Intermediate Panels, 1 Idler Panel



SPECIFIC DIMENSIONS OF EACH FABRIC PANEL SHOULD BE PROVIDED BY CUSTOMER USING the form titled: [Measuring Motorized FlexShades for Angled Coupler](#)

Select Motor Location

As seen from **INSIDE** the room facing the window. Also indicate on room schedule.

- Right Side (standard)
- Left Side

Select 120V AC Intelligent Technology Motor (ILT)

- 120V RS485 Quiet Sonesse Motor (standard)
- 120V RS485 ULTRA Quiet Sonesse Motor

Select Control Options

- 6 Button Digital Keypad
- 8 Button Digital Keypad
- Data Hub



Draper, Inc. | 411 S. Pearl St. Spiceland, IN 47385
draperinc.com | 765.987.7999 | 800.238.7999

© 2022 All Rights Reserved | FORM: AngCoup_FSMO_485AC_Sub22

PROJECT: _____

ARCHITECT: _____

CONTRACTOR: _____

SUPPLIER: _____

DATE: _____ REVISED: _____

Specifications

EQUIPMENT

485 SONESSE 120V INTELLIGENT TECHNOLOGY ELECTRIC OPERATOR: Drive unit inside roller, 3-wire, instantly reversible, lifetime lubricated. Right hand motor location standard. Left hand available. Built-in encoder and low voltage controller with data cable. Limit switches adjustable using wall switch or remote control. Thermal overload protector and electric brake. Operates on 110-120V AC 1 HP 60 HZ current. Draws 1.1 Amps.

HARDWARE

ROLLERS: Extruded aluminum or steel. Roller assembly easily removable.

ROLLER IDLER ASSEMBLY: Injection molded nylon and a zinc-plated cold rolled steel pin. Sliding pin for easy installation and removal of the roller.

SLAT: Aluminum, min. 1/8" x 1" (3 x 25mm), enclosed in heat sealed hem.

ENDCAPS: Zinc plated steel stamping. 4 1/2" x 4 1/2" (114x114mm). Complete with adapter roller bracket. Installs to wall, ceiling, or jamb. Accepts fascia or headbox.

ENDCAP COVERS: Plastic covers snap onto endcaps. Available in silver, ivory, bronze, black or white to match fascia.

FASCIA: "L" cover of extruded aluminum, .060 (1.5mm) wall. Fascia snaps onto endcaps. Clear Anodized (standard), black, white, ivory, or bronze powder coat finish available.

REVERSE ROLL FASCIA: "L" cover of extruded aluminum, .060 (1.5mm) wall. Fascia attaches onto endcaps. With Attachment Clips. Clear Anodized (standard), black, white, ivory, or bronze powder coat finish available.

SURFACE HEADBOX: Consists of fascia, L-shaped back/top cover. Endcaps slide into extrusion without exposed fasteners.

STRAIGHT COUPLER ASSEMBLY: Zinc plated steel Coupler Shafts shall be retractable into coupler assembly for ease of installation and to lock units in place. Zinc plated steel coupler brackets shall have spherical OD bearings allowing for misalignment of the mounting brackets of up to 1.25-degrees. One motor or crank operator to drive additional shade rollers. Patent pending.

ANGLED COUPLER ASSEMBLY: Adjustable to accommodate wall angles of 90° to 270°. Inside corners 0° - 179°; Outside corners 181° to 270°. Gear wheel of Delrin 500AL with applied Super Lube grease.

PATENT INFORMATION: available at <http://www.draperinc.com/legal/patents/>

DOWNLOADABLE 3-PART SPECIFICATIONS: available at www.draperinc.com.

Please note: Dimensions of rollers, operators and hardware at manufacturer's discretion.

Hardware Dimensions

Please Note: Endcaps have the attachment points for mounting a Motorized FlexShade. Optional fascia and headbox have a thickness of 1/16" (1.5mm).

Motorized FlexShade Endcap Mounting Dimensions

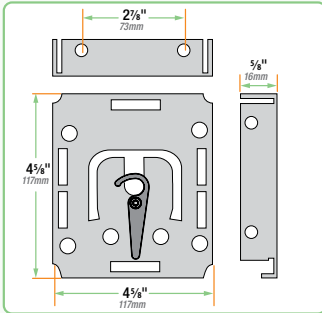

Angled Coupler Mounting Dimensions

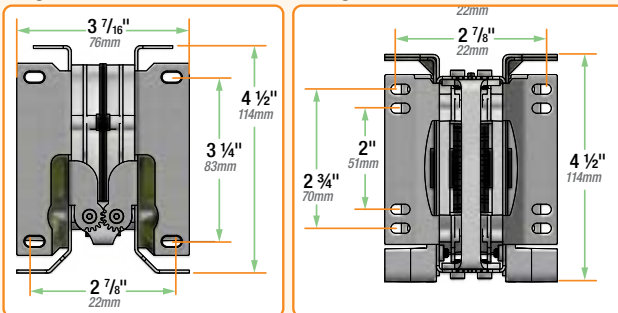

Endcap Covers

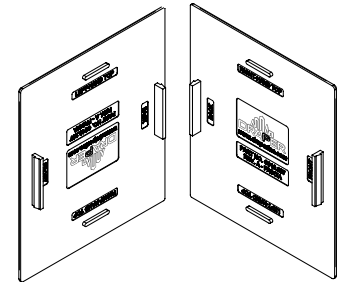

Installation Options

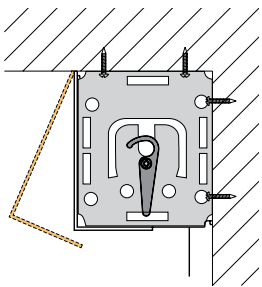

Ceiling or Wall Mounting Endcaps with Optional Fascia

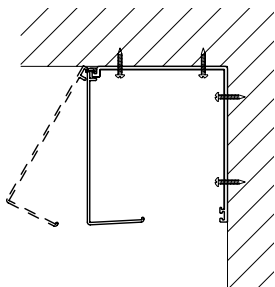

Surface Headbox Consists of:

- Fascia,
- Back/Top Cover
- Ceiling/Wall Endcaps

Standard Fascia

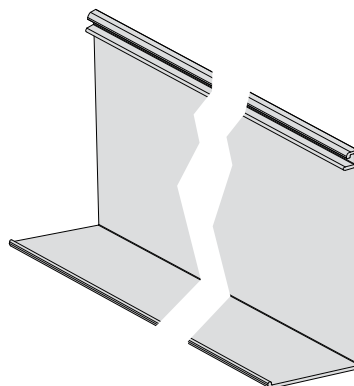

Reverse Roll Fascia

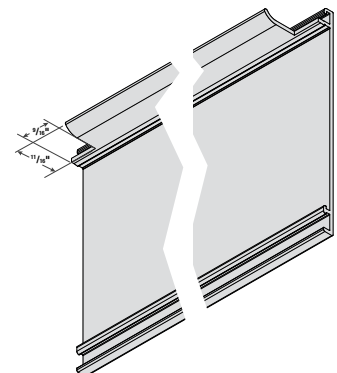

Slat Options

Standard Hem Bar Sealed End



1" aluminum elliptical slat inside of a 1-5/8" pocket with heat sealed ends.

Hem Bar Open End (Optional)



Plastic hem bar end caps provide a finished look. 1" aluminum elliptical slat inside of 1-5/8" heat seamed pocket with open pocket ends. Plastic end caps on hem bar.

Exposed Hem Bar Small Rectangular (Optional)



7/8" X 5/16" aluminum rectangular hem bar with plastic end caps.

Exposed Hem Bar Large Rectangular (Optional)



1-1/2" X 5/16" aluminum rectangular hem bar with plastic end caps.

Exposed Hem Bar Round



(Optional) 3/4" aluminum round hem bar with plastic end caps.

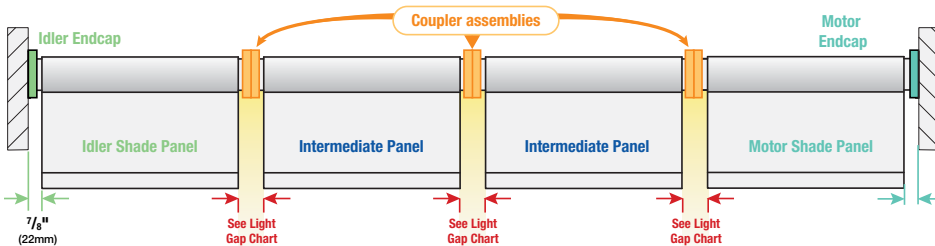

Light Gap dimension will vary depending on fabric orientation (e.g. - reverse roll). See chart below.

MOTOR TYPE
Round-Head
Square-Head
Star-Head
Gaposa

Roller Diameter			
2"	50.8mm	3"	76.2mm
15/16"	23.8mm	1"	25.4mm
1 1/16"	27mm	1 1/4"	31.8mm
1 3/16"	30.2mm	1 3/8"	35mm
1 1/8"	27mm	1 1/4"	27mm

LIGHT GAP for INSIDE WALL ANGLES: 90° to 179°

Angle°	2" Roller				3" Roller			
	Standard Roll		Reverse Roll		Standard Roll		Reverse Roll	
	Inches	mm	Inches	mm	Inches	mm	Inches	mm
175°	2.7"	68.6	2.5"	63.5	2.8"	71.1	2.5"	63.5
170°	2.9"	73.7	2.5"	63.5	3"	76.2	2.5"	63.5
165°	3.1"	78.7	2.5"	63.5	3.2"	81.3	2.4"	63.5
160°	3.2"	81.3	2.5"	63.5	3.5"	88.9	2.4"	63.5
155°	3.4"	86.4	2.5"	63.5	3.7"	94.0	2.3"	58.4
150°	3.6"	91.4	2.5"	63.5	3.9"	99.1	2.3"	58.4
145°	3.7"	94.0	2.5"	63.5	4.1"	104.1	2.2"	55.9
140°	3.9"	99.1	2.5"	63.5	4.3"	109.2	2.1"	53.3
135°	4"	101.6	2.4"	61	4.5"	114.3	2.1"	53.3
130°	4.2"	106.7	2.4"	61	4.6"	116.8	2"	50.8
125°	4.3"	109.2	2.4"	61	4.8"	121.9	1.9"	48.3
120°	4.4"	111.8	2.4"	61	5"	127	1.9"	48.3
115°	4.6"	116.8	2.3"	58.4	5.1"	129.5	1.8"	45.7
110°	4.7"	119.4	2.3"	58.4	5.3"	134.6	1.7"	43.2
105°	4.8"	121.9	2.2"	55.9	5.4"	137.2	1.6"	40.6
100°	4.9"	124.5	2.2"	55.9	5.5"	139.7	1.5"	38.1
95°	4.9"	124.5	2.1"	53.3	5.7"	144.8	1.5"	38.1
90°	5"	127	2.1"	53.3	5.8"	147.3	1.4"	35.6

LIGHT GAP for OUTSIDE WALL ANGLES 181° to 270°

Angle°	2" Roller				3" Roller				
	Standard Roll		Reverse Roll		Standard Roll		Reverse Roll		
	Inches	mm	Inches	mm	Inches	mm	Inches	mm	
185	2.5"	63.5	2.7"	68.6	185	2.5"	63.5	2.8"	71.1
190	2.5"	63.5	2.9"	73.7	190	2.5"	63.5	3"	76.2
195	2.5"	63.5	3.1"	78.7	195	2.4"	63.5	3.2"	81.3
200	2.5"	63.5	3.2"	81.3	200	2.4"	63.5	3.5"	88.9
205	2.5"	63.5	3.4"	86.4	205	2.3"	58.4	3.7"	94.0
210	2.5"	63.5	3.6"	91.4	210	2.3"	58.4	3.9"	99.1
215	2.5"	63.5	3.7"	94.0	215	2.2"	55.9	4.1"	104.1
220	2.5"	63.5	3.9"	99.1	220	2.1"	53.3	4.3"	109.2
225	2.4"	61	4"	101.6	225	2.1"	53.3	4.5"	114.3
230	2.4"	61	4.2"	106.7	230	2"	50.8	4.6"	116.8
235	2.4"	61	4.3"	109.2	235	1.9"	48.3	4.8"	121.9
240	2.4"	61	4.4"	111.8	240	1.9"	48.3	5"	127
245	2.3"	58.4	4.6"	116.8	245	1.8"	45.7	5.1"	129.5
250	2.3"	58.4	4.7"	119.4	250	1.7"	43.2	5.3"	134.6
255	2.2"	55.9	4.8"	121.9	255	1.6"	40.6	5.4"	137.2
260	2.2"	55.9	4.9"	124.5	260	1.5"	38.1	5.5"	139.7
265	2.1"	53.3	4.9"	124.5	265	1.5"	38.1	5.7"	144.8
270	2.1"	53.3	5"	127	270	1.4"	35.6	5.8"	147.3

FlexShade Components

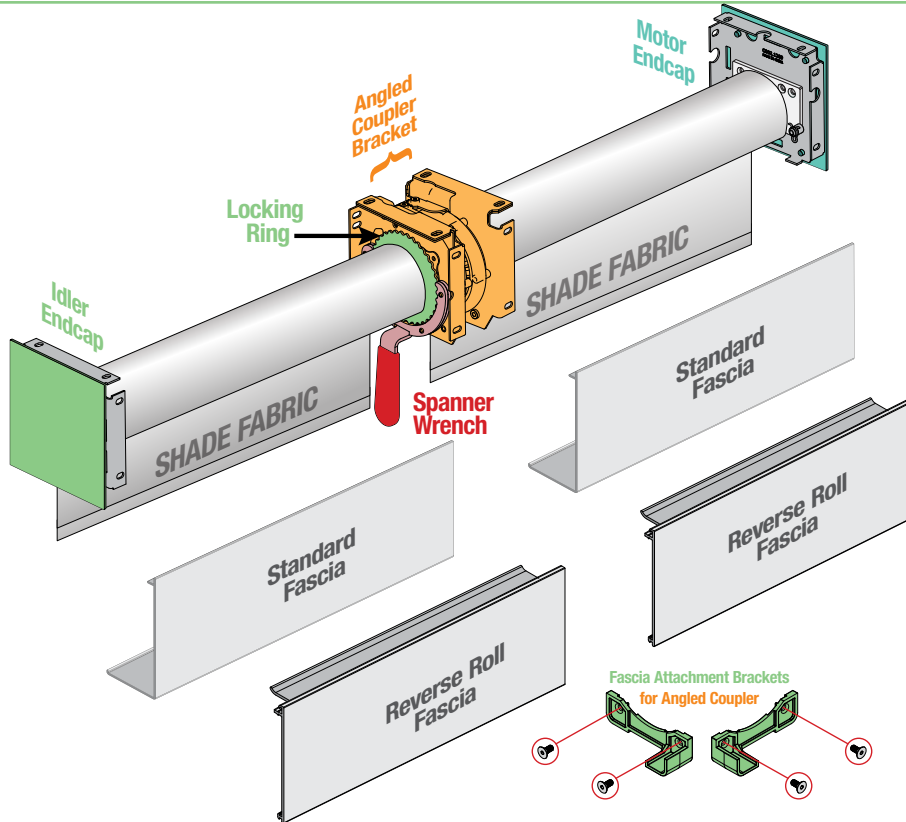

Wiring Diagrams

