

FLEXSHADE® PANELS

Non-operable sunlight filtration system

SUBMITTAL TECHNICAL INFO

Please check all appropriate selections and attach room schedule with verified dimensions.

Fabric Series: _____

Color Name / Number: _____

Openness Factor: _____

Please see Draper® Fabric Options for fabric colors and specifications.

Select Frame Color

- Clear Anodized
- Black
- Dark Bronze
- White

Select Frame Type

- Rectangular
- Triangular
- 5-Sided
- Gabled

Select Mounting Clips

Note: Each panel comes with 8 clips

- Inside
- Face
 - _____ # of extra clips needed
- Optional Mounting Track for installation on building exterior
(See dimensions on page 2)
- Side Keeper Track
Length: _____

Exterior Installation

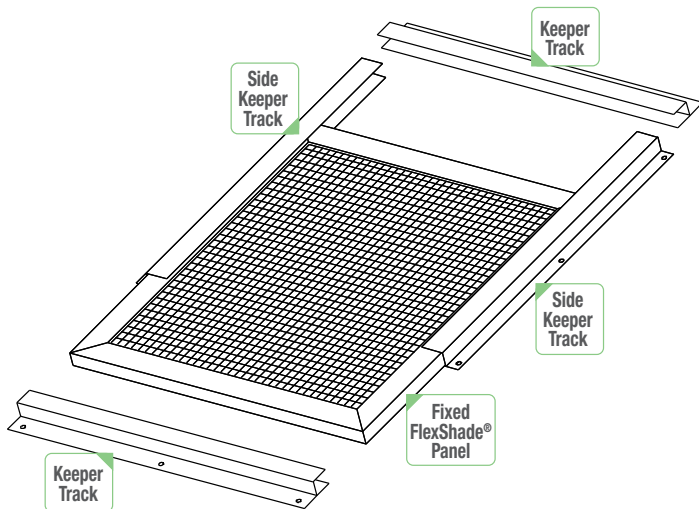

Interior Mounting Clips and Installation Options

Face Mounting

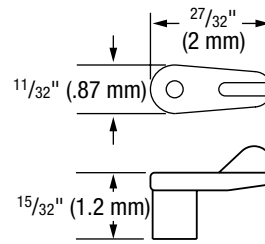
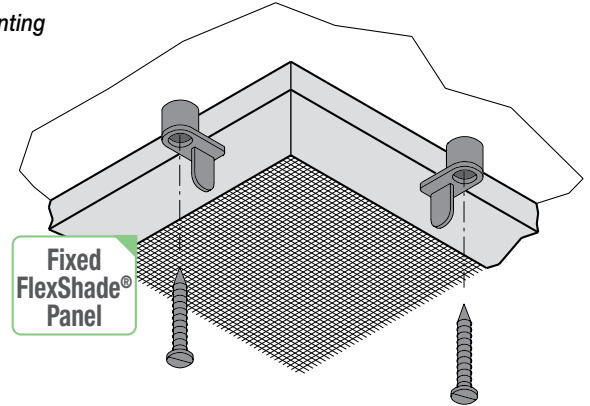

Inside Mounting

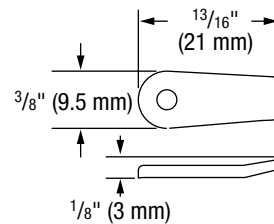
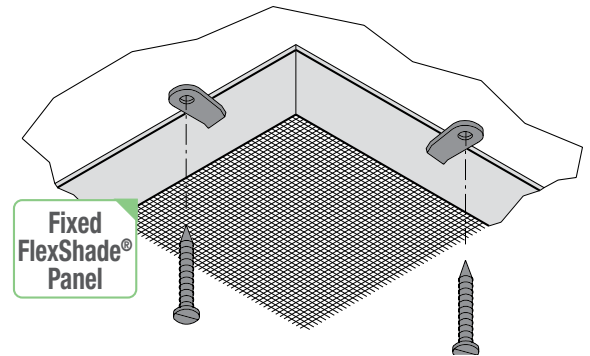

Draper, Inc. | 411 S. Pearl St. Spiceland, IN 47385
draperinc.com | 765.987.7999 | 800.238.7999
© 2026 All Rights Reserved | FORM: FS_Panels_Sub26

PROJECT: _____

ARCHITECT: _____

CONTRACTOR: _____

SUPPLIER: _____

DATE: _____ REVISED: _____

Specifications

EQUIPMENT

FLEXSHADE PANELS: Fixed panels, for interior and exterior applications, to consist of aluminum framing, with open weave glare control fabrics splined in frame groove with vinyl spline. Fabrics available in a variety of openness configurations and colors, to be specified from manufacturer's standard offering. Frames attach to glazing frames, either inside or ceiling/wall, with clips provided. Units for mounting on building exterior install in extruded slide tracks. Removable for cleaning and maintenance.

FRAMING: Extruded framing, to be min. of $\frac{3}{4}$ " x $\frac{3}{8}$ " x .019", or larger, at manufacturer's discretion. Units exceeding 40" in length or width to have center cross brace. Finish available in mill finish aluminum, dark bronze, or white. Mounting clips heads will closely match frame finish. Heavy duty extruded track available for mounting on exterior of building. Mounting hardware by others.

FABRICS

PHIFER SUNSCREEN® SERIES SW1000: Woven vinyl-coated fiberglass screening. Approx. 23% open. It is noncombustible and will not rust, corrode, shrink, scratch or stain.

FOR OTHER FABRIC SPECIFICATIONS: please refer to Draper's Shade Fabrics Reference Sheet, available at www.draperinc.com.

PLEASE NOTE: Extreme air currents or physical interference may cause product failure.

DOWNLOADABLE 3-PART SPECIFICATIONS: available at www.draperinc.com.

Please note: Dimensions of rollers, operators, and hardware at manufacturer's discretion.

Sunscreen is a registered trademark of Phifer.

Hardware Selection

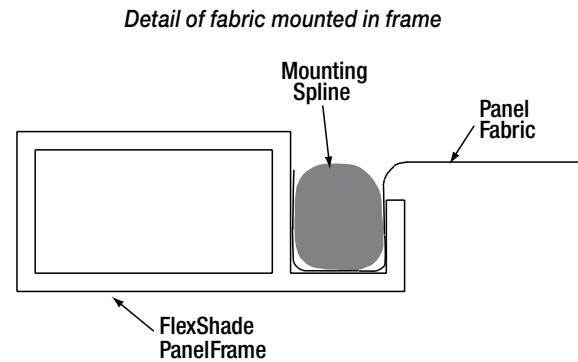
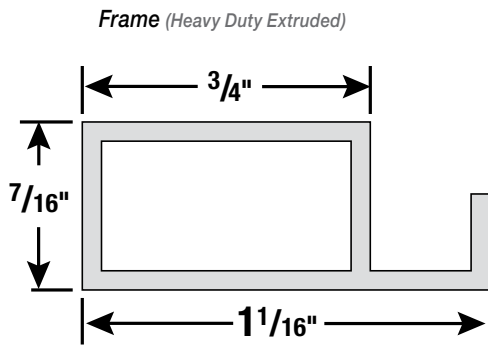

Exterior Mounting Hardware

