

Access XL E

Extra large, ceiling-recessed electric screen



SUBMITTAL TECHNICAL INFO

Specifications **Please check all appropriate selections and attach room schedule with verified dimensions.**

QUANTITY: _____ SIZE: _____ h. x _____ w.

Projection screens for recessed ceiling mounting. Case back, top, and front constructed of steel. Endcaps are steel. Bottom panel forms slot for passage of viewing surface, easily removable for access. Housing allows for left- or right-hand motor location and for viewing surface to unroll from the back or front of the roller. Housing includes bottom flange for trim around edges of ceiling opening. Case may be mounted with 3/8" (9.5mm) threaded rod, or with 3/8" (9.5mm) lag screws through mounting brackets. Mounting brackets slide in 18" (45.7cm) long channels on top of case, allowing brackets to be moved to avoid interference with conflicting building structures. Brackets must be locked in position by tightening screws. In typical installations, mounting brackets may be angled to meet installation requirements.

Roller/fabric assembly installed in case at factory. Brackets supporting roller/fabric assembly to slide in track inside top of case, allowing viewing surface to be centered in case. Roller of 5" (12.7cm) dia. metal. Viewing surface flame and mildew resistant.

Electrically operated 110-120V AC, 60 Hz, 4-wire motor mounted inside screen roller, max 2.1 Amp current draw, instantly reversible, lifetime lubricated, with internal thermal overload protector and electric brake, standard motor with preset accessible switches. Housing features internal junction box, allowing it to be installed and wired to building supply wires at an early stage of construction. Junction box has plug-in style connector, accepting the mating half of the connector from the motorized roller/fabric assembly. 3-position control switch (or switches—specify number) to stop or reverse screen at any point. Switch(es) furnished with cover plate.

Entire unit certified by Underwriters' Laboratories for the U.S. and Canada. Plenum rated case (UL approved "Suitable for Use in Environmental Air Space"). Specifications subject to change without notice. For more information, visit ul.com/gg.

DOWNLOADABLE 3-PART SPECIFICATIONS: available at www.draperinc.com

Please note: Dimensions of rollers, operators, and hardware at manufacturer's discretion.

Select Case Color:

- White (standard)
- Black (optional)



Select Viewing Surface:

- Matt White XT1000E (1.0 gain); GREENGUARD Gold certified
- Other: _____

Select Motor and Controls:

Standard Voltage Motor and Control Options:

- 110-120V AC (standard)

Please Note: This motor comes with one 110V-120V AC 3-position wall switch (silver wall plate with black rocker).

_____ Total number of 110-120V AC switches (operate independently)

- Substitute white switch(es) for silver wall plate with black rocker
- Optional Key Operated Switch
 - Power Supply Key Switch (on-off)
 - 3-Position Key Control
 - 3-Position Switch with Hinged Key-Locking Coverplate

Low-Voltage Control Options:

- Internal LVC-IV (Low-Voltage Control Module)
- External LVC-IV (Low-Voltage Control Module)
- Motor with Internal Low-Voltage Controller

Please Note: Select Control Options for Low-Voltage from below.

- 24 Volt 3-Button Switch
Number of 24V switches: _____
- Radio Frequency Remote Control (only with 24V)
- Infrared Remote Control (only with 24V)
- Optional Key Operated Switch
 - Power Supply Key Switch (on-off)
 - 3-Position Switch with Hinged Key-Locking Coverplate

Select Motor Location:

- Left end (standard) (fabric rolls off back of roller)
- Right end (fabric rolls off front of roller)

Optional Accessories:

- Additional Drop _____ (beyond standard 12" (30cm))
- Total Drop _____ (standard 12" (30cm) + additional drop)
 - Black (standard)
 - Same color as viewing surface
(Total screen height cannot exceed 22' (6.7m); extra drop increases length of case)

Dimensions and Data

16:10 Format

Nominal Diagonal	Image Area	Overall Size	Case Length ¹	Net Wt. (lbs.)	Qty.
255"	135" x 216"	140" x 220"	233 3/4"	260	
278"	147 1/2" x 236"	152 1/2" x 240"	253 3/4"	284	

HDTV Format (16:9)

Nominal Diagonal	Image Area	Overall Size	Case Length ¹	Net Wt. (lbs.)	Qty.
248"	121 1/2" x 216"	126 1/2" x 220"	233 3/4"	256	
270"	133" x 236"	138 1/2" x 240"	253 3/4"	279	

NTSC Video Format (4:3)

Nominal Diagonal	Image Area	Overall Size	Case Length ¹	Net Wt. (lbs.)	Qty.
250"	148" x 198"	153" x 202"	215 3/4"	246	
270"	162" x 216"	167" x 220"	233 3/4"	250	
295"	177" x 236"	182" x 240"	253 3/4"	271	

Audio Visual Format

Size H x W	Case Length	Net Wt. (lbs.)	Qty.
16' x 16'	205 3/4"	240	
13'6" x 18'	229 3/4"	246	
18' x 18'	229 3/4"	256	
8' x 20'	253 3/4"	256	
15' x 20'	253 3/4"	272	
20' x 20'	253 3/4"	283	

Custom Size (available up to 240" w.)

Size H x W	Case Length	Net Wt. (lbs.)	Qty.

¹ Includes 3/4" (19 mm) flange on each end of case. Subtract 1 1/4" (32 mm) for rough ceiling cutout size.



PROJECT: _____

ARCHITECT: _____

CONTRACTOR: _____

SUPPLIER: _____

DATE: _____ REVISED: _____

Case Dimensions and Methods of Installation

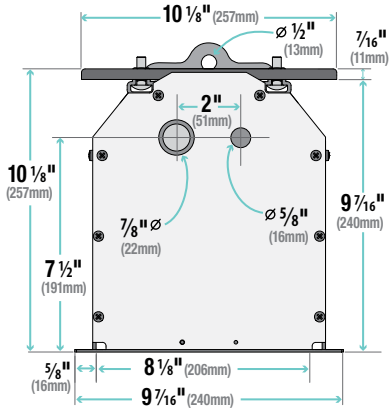

Standard Motor Wiring is on the **AUDIENCE LEFT END** of Screen Case.

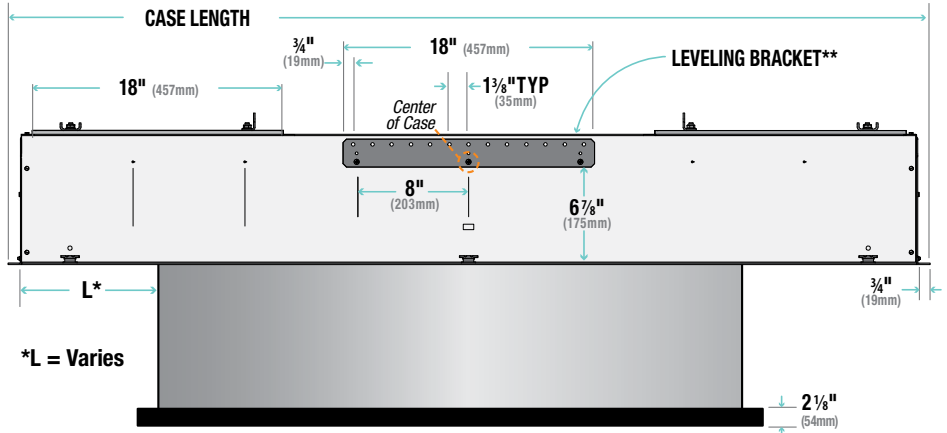

- For minimum length of ceiling cutout: subtract 1 1/4" (32mm) from case length (measured from outer edge of flanges).
- For minimum width of cutout (front to back): see case width dimensions below.
- **Leveling bracket is used to level the case and should NOT be used to support the weight of the unit.
- The leveling bracket is screwed to the side of the case. Hardware used for leveling provided by others.
- There are several knock-outs in the screen housing to allow the leveling bracket to be adjusted laterally up to 16" (40.6cm) in either direction.

Ceiling Mounting Bracket Locations and Configurations

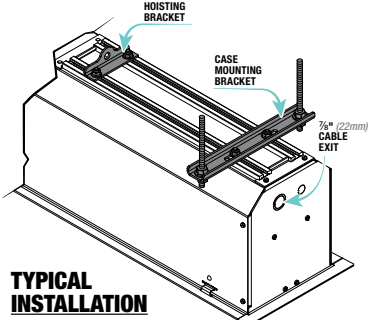

TYPICAL INSTALLATION

With typical installation, brackets may be angled to meet installation requirements.

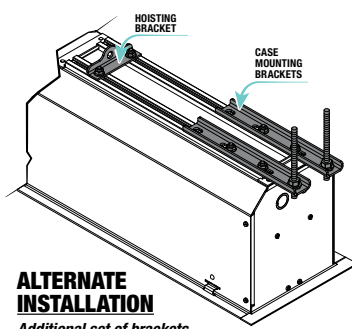

ALTERNATE INSTALLATION

Additional set of brackets required, but **NOT** included.

Mounting Bracket Dimensions

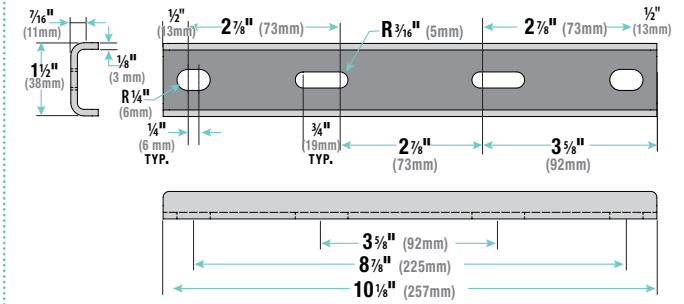

Wiring Diagrams

110-120V Motor 110-120V MOTOR AND QUIET MOTOR Single Station Control

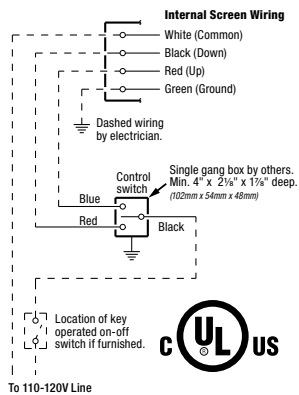

110-120V Motor

(motor with internal low-voltage controller)

Single Station Control

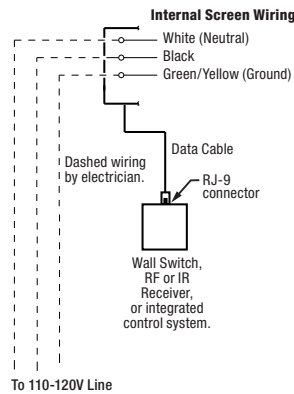

Multiple Station Control

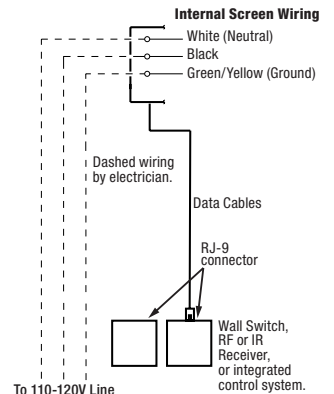

Please Note: For external low-voltage (LVC-IV), serial (LVC-IV), and network (LVC-IV) wiring diagrams, please consult instructions for those modules.

PROJECT: _____

ARCHITECT: _____

CONTRACTOR: _____

SUPPLIER: _____

DATE: _____ REVISED: _____