

Volleyball Floor Anchors

By **DRAPER**

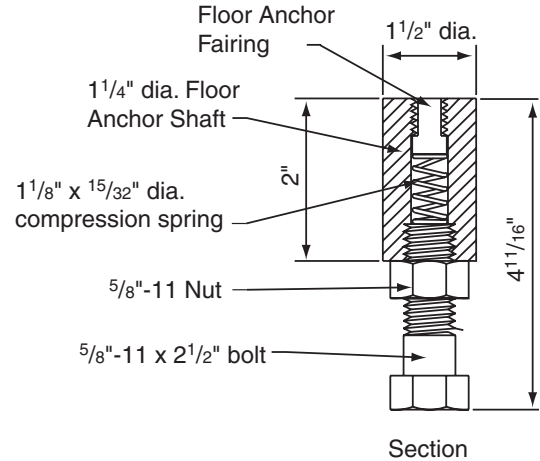
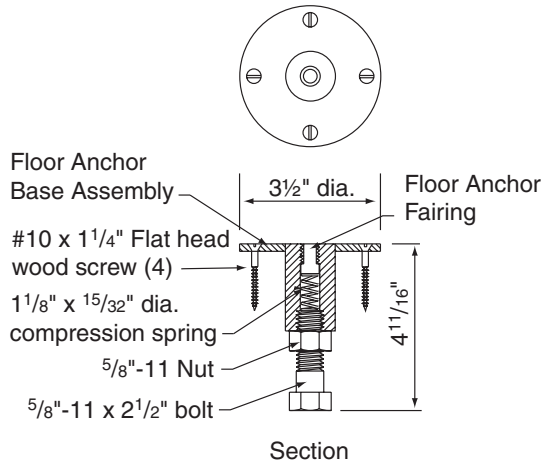

501011 Floor Anchor—For Wood Floor Over Concrete

Product Description

Specify _____ floor anchors, manufactured by Draper, Inc., Spiceland, Indiana. One piece floor anchor shall be chrome-plated and designed for grout-in installation. Anchors shall have spring-loaded flush fairings with standard 1/2"-13 NC threads. Model 501011 shall be used for wood over concrete floors.

501012 Floor Anchor—For Concrete or Tile Floor

Product Description

Specify _____ floor anchors, manufactured by Draper, Inc., Spiceland, Indiana. One piece floor anchor shall be chrome-plated and designed for grout-in installation. Anchors shall have spring-loaded flush fairings with standard 1/2"-13 NC threads. Model 501012 shall be used for tile, concrete or rubber floors.

DRAPER

411 S. Pearl St., Spiceland, IN 47385 USA ■ 765-987-7999 ■ fax 765-987-7142
e-mail draper@draperinc.com ■ www.draperinc.com

Copyright © 2004 Draper Inc.

Form VB-FloorAnchors_Sub04

Printed in U.S.A.

PROJECT: _____
ARCHITECT: _____
CONTRACTOR: _____
SUPPLIER: _____
DATE: _____ REVISED: _____