

Elite Volleyball Systems

by DRAPER

500041 EVS-01

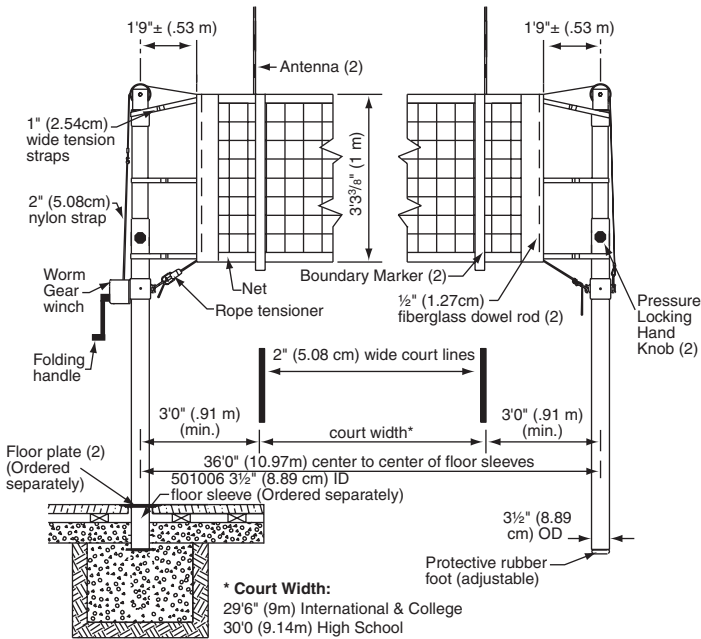

500042 EVS-02

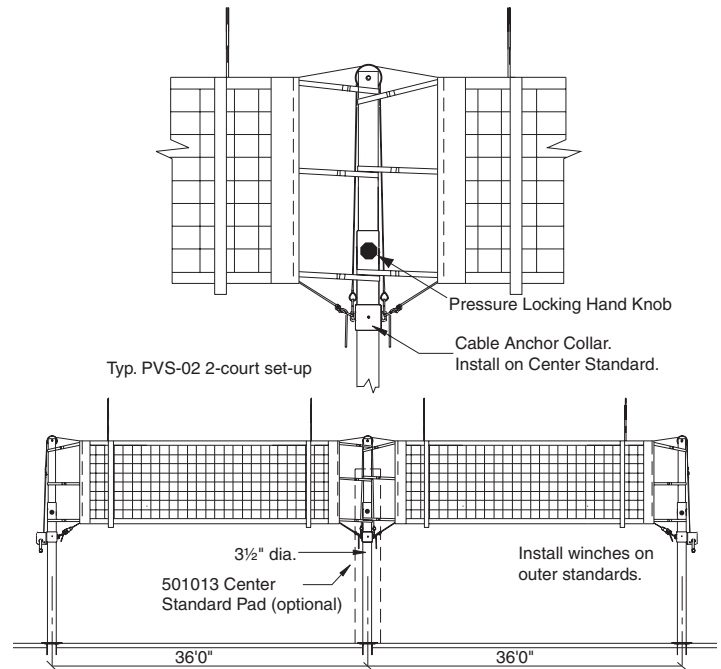

Please Mark Appropriate Selections

Select Power Volleyball System

- 500041 EVS-01 (Two-Pole System)
- 500042 EVS-02 (Three-Pole System)

Please Note: Specifications can be found on back page

Official Heights for USVBA, NCAA, and NFHS

Volleyball Heights	Girls	Boys
Grades 1-6 (Elem.)	6'1" (1.85m)	6'1" (1.85m)
Grades 7-9 (Middle School)	7'4 1/8" (2.24m)	7'4 1/8" (2.24m)
Grades 7-9 (Jr. High)	7'4 1/8" (2.24m)	7'11 5/8" (2.43m)
Grades 9-12 (Sr. High)	7'4 1/8" (2.24m)	7'11 5/8" (2.43m)
Collegiate & International	7'4 1/8" (2.24m)	7'11 5/8" (2.43m)

Note: Regulation net heights are set at center of net. Ends of net (at court lines) cannot exceed the regulation height by more than 3/4" (2 cm).

Net height is adjustable from 6'1" (1.85 m) to 8'4" (2.54 m) in 1" (2.54 cm) increments.

DRAPER®

411 S. Pearl St., Spiceland, IN 47385 USA ■ 765-987-7999
www.draperinc.com ■ fax 765-987-7142

Copyright © 2008 Draper Inc. Form VB-EliteVolleyballSystems_Sub08 Printed in U.S.A.

PROJECT: _____

ARCHITECT: _____

CONTRACTOR: _____

SUPPLIER: _____

DATE: _____ REVISED: _____

Specifications—500041

EVS-01 Two-Pole Elite Volleyball System

Product Description

Volleyball System shall be #EVS-01 Elite Volleyball System, No. 500041 by Draper, Inc. of Spiceland, IN. Post shall be telescoping type to meet all FIVB, USA Volleyball, NCAA and NFHS requirements for competition. Post shall allow infinite height adjustment from 6' (1.854 m) to 8'4" (2.540 m) to meet all age group height settings from elementary school use to international competition for both men and women. EVS-01 shall incorporate an internal spring assist mechanism for easy, precise and infinite height adjustments. EVS easily locks in place with a pressure lock hand knob and post is clearly marked at normal competition heights.

Clear anodized finish for professional looking appearance.

The 6' (1.890 m) bottom upright shall be 3½" O.D. (8.890 cm) schedule 80 aluminum tube, with a wall thickness of .300" (.7620 cm). The bottom upright is provided with a special rubber foot to protect finished floors and to provide precise net height adjustment.

The upper telescoping adjustable tube shall be 2⅞" O.D. (7.303 cm) schedule 80 aluminum tube, with a wall thickness of .300" (.7620 cm).

The tensioning winch shall incorporate a heavy-duty, self-locking worm gear mechanism. Winch shall be furnished with a heavy 2" (5 cm) wide high tensile nylon strap with heavy-duty snap hook to eliminate the possibility of hook breaking and guarantee safe connection to net top cable. The winch is furnished complete with a folding handle for player safety.

Secure cast-in-place 3½" I.D. floor sleeves with flush cover plates provide rigid support—for the life of the installation.

The 500041 EVS-01 shall consist of one telescoping standard with winch and one telescoping standard with adjustable cable anchor collar.

Volleyball Net shall be #500004 by Draper, Inc. of Spiceland, IN. Net shall be 32' (9.75 M) long x 39⅜" (1 M) high. Netting shall be high quality 4" square #36 black nylon cord with vinyl coated polyester hem double stitched around entire perimeter of net. Top hem of net shall be furnished with a 42'6" long x ⅛" diameter 2000 lb. minimum breaking strength galvanized aircraft cable with a nylon coating (⅜" O.D.) to protect against fraying. Ends of cable to have loops with heavy swaged type fittings for easy installation. Hems in end of net shall be furnished with a pocket for use with a ½" diameter fiberglass dowel rod. Ends of net shall have six 1" wide polypropylene tension straps with buckles for providing additional tightening of net. Bottom of net shall be furnished with a ¼" diameter braided white nylon rope equipped with a spring loaded, pressure type rope tensioner.

Rope Tensioner shall be #500005 by Draper, Inc. of Spiceland, IN.

Combination Antenna and Boundary Marker shall be #500016 by Draper, Inc. of Spiceland, IN.

Optional Protective Pads shall provide maximum player protection. Two, 5'8" high pads are constructed of 1½" thick, cross-linked polyethylene foam covered with polyester reinforced vinyl fabric. Dark blue is standard; other colors available.

STANDARD DIMENSIONS

36'0" center to center of standards/sleeves.

Specifications—500042

EVS-02 Three-Pole Elite Volleyball System

Product Description

Volleyball System shall be #EVS-02 Elite Volleyball System, No. 500042 by Draper, Inc. of Spiceland, IN. Post shall be telescoping type to meet all FIVB, USA Volleyball, NCAA and NFHS requirements for competition. Post shall allow infinite height adjustment from 6' (1.854 m) to 8'4" (2.540 m) to meet all age group height settings from elementary school use to international competition for both men and women. EVS-02 shall incorporate an internal spring assist mechanism for easy, precise and infinite height adjustments. EVS easily locks in place with a pressure lock hand knob and post is clearly marked at normal competition heights.

Clear anodized finish for professional looking appearance.

The 6' (1.890 m) bottom upright shall be 3½" O.D. (8.890 cm) schedule 80 aluminum tube, with a wall thickness of .300" (.7620 cm). The bottom upright is provided with a special rubber foot to protect finished floors and to provide precise net height adjustment.

The upper telescoping adjustable tube shall be 2⅞" O.D. (7.303 cm) schedule 80 aluminum tube, with a wall thickness of .300" (.7620 cm).

The tensioning winch shall incorporate a heavy-duty, self-locking worm gear mechanism. Winch shall be furnished with a heavy 2" (5 cm) wide high tensile nylon strap with heavy-duty snap hook to eliminate the possibility of hook breaking and guarantee safe connection to net top cable. The winch is furnished complete with a folding handle for player safety.

Secure cast-in-place 3½" I.D. floor sleeves with flush cover plates provide rigid support—for the life of the installation.

The 500042 EVS-02 shall consist of two standards with winch and adjustable cable anchor collar, and 501013 center standard.

Volleyball Nets shall be #500004 by Draper, Inc. of Spiceland, IN. Net shall be 32' (9.75 M) long x 39⅜" (1 M) high. Netting shall be high quality 4" square #36 black nylon cord with vinyl coated polyester hem double stitched around entire perimeter of net. Top hem of net shall be furnished with a 42'6" long x ⅛" diameter 2000 lb. minimum breaking strength galvanized aircraft cable with a nylon coating (⅜" O.D.) to protect against fraying. Ends of cable to have loops with heavy swaged type fittings for easy installation. Hems in end of net shall be furnished with a pocket for use with a ½" diameter fiberglass dowel rod. Ends of net shall have six 1" wide polypropylene tension straps with buckles for providing additional tightening of net. Bottom of net shall be furnished with a ¼" diameter braided white nylon rope equipped with a spring loaded, pressure type rope tensioner.

Rope Tensioner shall be #500005 by Draper, Inc. of Spiceland, IN.

Combination Antenna and Boundary Marker shall be #500016 by Draper, Inc. of Spiceland, IN.

Optional Protective Pads shall provide maximum player protection. Two, 5'8" high pads are constructed of 1½" thick, cross-linked polyethylene foam covered with polyester reinforced vinyl fabric. Dark blue is standard; other colors available.

STANDARD DIMENSIONS

36'0" center to center of standards/sleeves (each court).

LEED® Submittal Information

Credit	Measure	
MRc4 – Recycled Content	Post Consumer Average 42.8%	Post Industrial 0%
MRc5 – Regional Materials	Product Manufactured in Spiceland, IN 47385	