

Volleyball Transporters

by **DRAPER**

501023

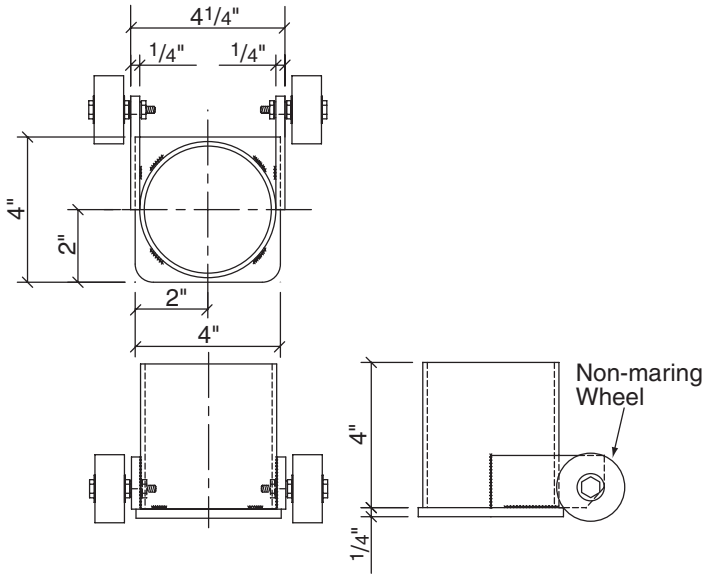

Specifications—501023 Single Volleyball Post Transporter

Product Description

For transporting a single volleyball post, specify Draper Model No. 501023 Single Volleyball Post Transporter.

Model No. 501023 Single Post transporter is constructed with 3 1/2" ID tube welded to 1/4" thick flat plate. Transporter features two 1 1/2" non-marking nylon casters. Entire unit is finished in attractive gloss black powder coat. Post transporter makes it easy to move volleyball posts to and from storage area.

501016

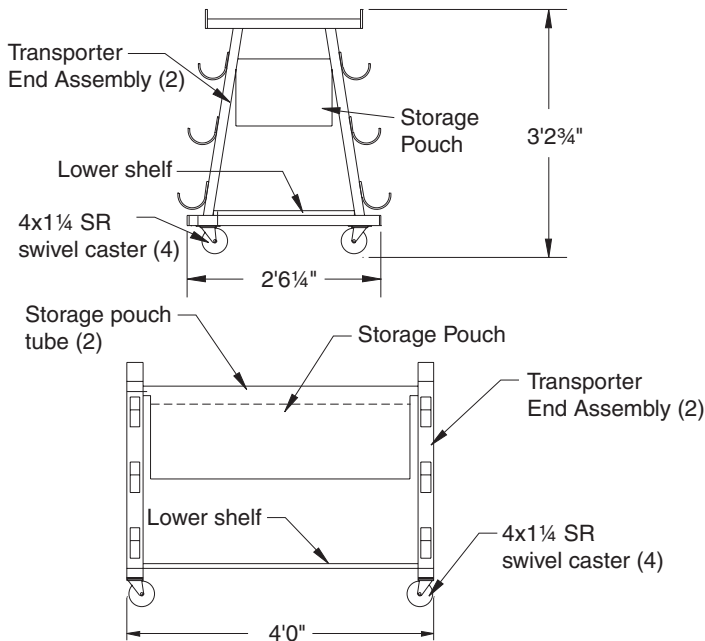

Specifications—501016 Volleyball Transporter

Product Description

Heavy-Duty Volleyball Transporter shall be 501016 by Draper, Inc. of Spiceland, IN.

Heavy-duty transporter is designed to store entire PVS-01 System 500001. Transporter rolls on swivel casters.

DRAPER[®]

411 S. Pearl St., Spiceland, IN 47385 USA ■ 765-987-7999
www.draperinc.com ■ fax 765-987-7142

Copyright © 2008 Draper Inc. Form VB-501023-501016-Transporters_Sub08 Printed in U.S.A.

PROJECT: _____

ARCHITECT: _____

CONTRACTOR: _____

SUPPLIER: _____

DATE: _____ REVISED: _____