

Assembly Instructions

501016 Volleyball Transporter by Draper

⚠ Caution

- ① Read instructions through completely before proceeding.
- ② Equipment Cart/Transporter should only be used for intended purpose of moving and storing volleyball equipment.
- ③ Casters should be kept clean and free from debris to protect playing surface from damage.
- ④ These Instructions are meant as a guide only. They do not imply any responsibility on part of Draper, inc for improper installation or faulty workmanship at the jobsite.

Tools Required

¾" Wrench, 7/16" Wrench, Drill with 5/16" Bit

Parts List

Part No.	Qty	Description
C028.206SA	2	Transporter End Assembly
C073.173	2	Storage Pouch Tube
C238.003	1	Vinyl Wrapped Lower Shelf
C192.010	1	Vinyl Storage Pouch
C035.004	4	4" x 1¼" Swivel Caster
C020.266	4	½"-13 x 2" Hex Head Cap Screw
C020.323	8	¼"-20 x 1¾" Hex Head Cap Screw
C019.033	8	¼"-20 x 2¼" Carriage Bolt
C018.052	16	¼"-20 Keps Nut
C013.033	16	¼" Flat Washer

Assembly Instructions

- ① Unpack all component parts and check against Parts List to ensure all have been included.
- ② Slide a Storage Pouch Tube through each top pocket in the Vinyl Storage Pouch.
- ③ Attach Storage Tubes to each Transporter End Assembly using ½"-13 x 2" Hex Head Cap Screws.
- ④ Place subassembly of Transporter End Assemblies and Storage Pouch Tubes upside down on floor with Storage Pouch open toward the floor.
- ⑤ Place Vinyl Wrapped Storage Shelf inside Transporter End Assembly with vinyl toward floor.
- ⑥ Align end of board with outside edge of rectangular tube at bottom of Transporter End Assembly and drill two holes in one corner of the shelf using holes in bottom tube of the Transporter End Assembly as guide.
- ⑦ Place ¼"-20 x 2" carriage bolts through holes drilled with head toward floor (to side with vinyl). Push carriage bolts through holes in Transporter End Assembly.
- ⑧ Attach a Swivel Caster to Transporter End Assembly by placing over ends of carriage bolts and securing with ¼" Washer and ¼"-20 Keps Nut.
- ⑨ Place two ¼"-20 x 1¾" Hex Head Cap Screw through other holes into each caster with the bolt head toward the floor (away from caster) and secure with ¼" washer and ¼"-20 Keps Nut.
- ⑩ Repeat steps 6-9 for all four casters.
- ⑪ Turn assembled cart over and place casters on floor.
- ⑫ Your Storage Cart/Transport is now ready to use.

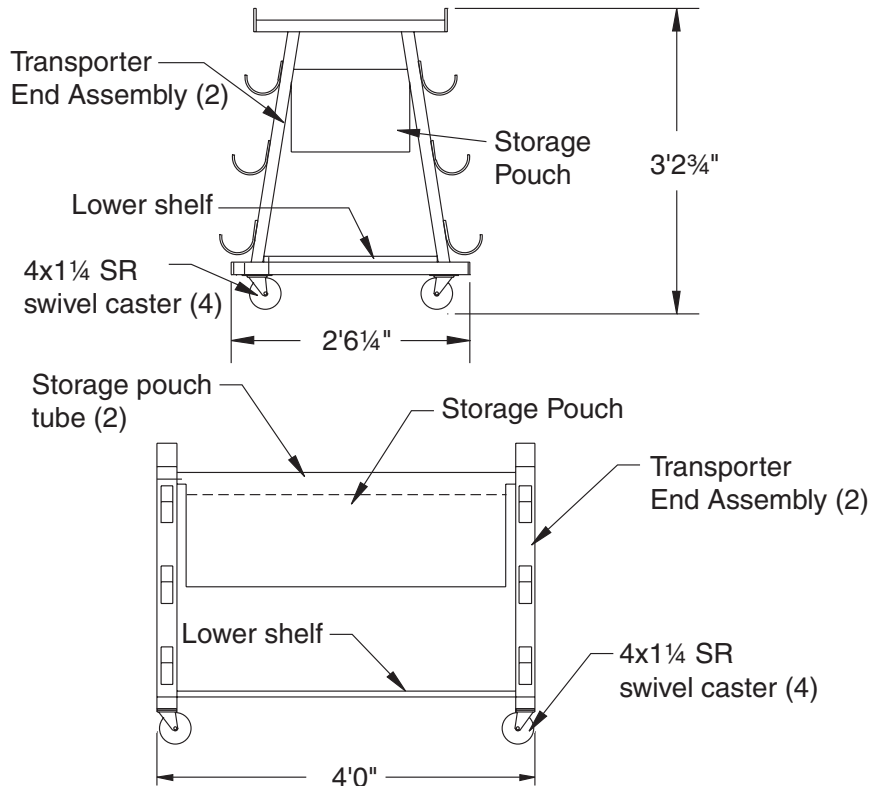

DRAPER®

411 S. Pearl St., Spiceland, IN 47385 USA ■ 765-987-7999

www.draperinc.com ■ fax 765-987-7142

Copyright © 2008 Draper Inc. Form VB-Equipment-Transporter_Inst08 Printed in U.S.A.

If you encounter any difficulties installing or servicing your transporter cart, call your dealer or Draper, Inc., Spiceland, Ind., (765) 987-7999, or fax (765) 987-7142.