

501011

Floor Anchor

501012

Floor Anchor by

DRAPER

NOTE: Both anchors on this page fit the 500008 PTVS-01 and 500009 PTVS-02 Portable Volleyball Systems.

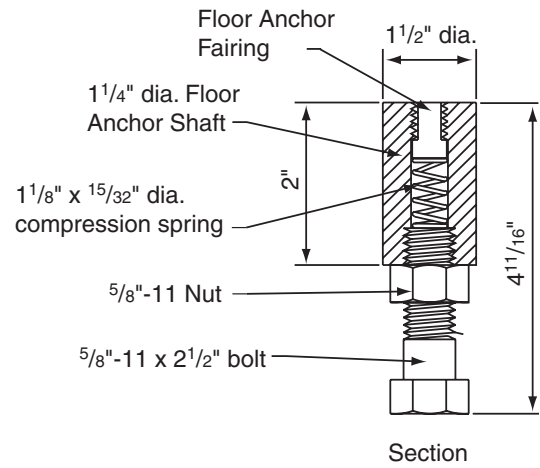
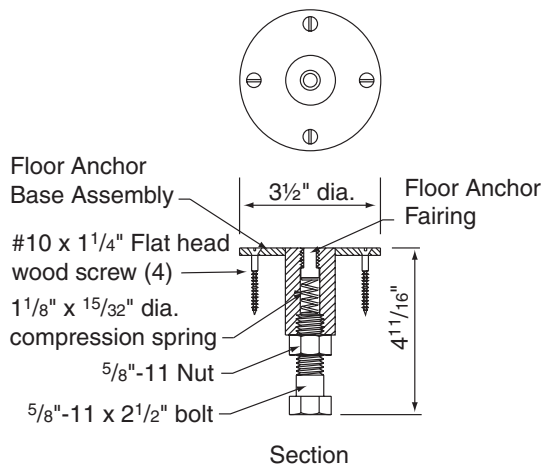

Installation Instructions—501011

Floor Anchor—For Wood Floor Over Concrete

- ① Locate center of anchor at required location.
- ② Turn anchor upside down and scribe around outside.
- ③ Locate center of circle and drill 1 1/4" depth and route out circle.
- ④ Set router at 1/4" depth and route out circle.
- ⑤ Drill concrete with 1 1/4" diameter hole 5 1/2" from finished floor.
- ⑥ Mix approximately one (1) cup of fast setting grout and pour in hole.
- ⑦ Insert floor anchor in hole and tap down level with finished floor.

Please Note: Use wood block between anchor and hammer so as not to damage chrome plated anchor.

- ⑧ Insert four(4) #10 Phillips wood screws.
- ⑨ Let anchor set for one (1) week before using.

Installation Instructions—501012

Floor Anchor—For Concrete or Tile Floor

- ① Locate center of anchor at required location.
- ② Drill concrete with 1 1/4" diameter hole 5 1/2" from finished floor.
- ③ Mix approximately one (1) cup of fast setting grout and pour in hole.
- ④ Insert floor anchor in hole and tap down level with finished floor.

Please Note: Use wood block between anchor and hammer so as not to damage chrome plated anchor.

- ⑤ Let anchor set for one (1) week before using.

DRAPER