

# Colossal FlexShade

Large Motorized Window  
Shade With Motor-In-Roller by



## Specifications—Colossal FlexShade

\_\_\_\_\_ window shades, size \_\_\_\_\_ w. x \_\_\_\_\_ h., electrically operated 110-120V AC 60 Hz. 3-wire motor mounted inside shade roller, 2.5 amp draw, instantly reversible, lifetime lubricated, with internal thermal overload protector and mechanical brake. Motor mounted with sound-absorbing fixtures. Preset, accessible limit switches. **Right hand motor location standard**; left hand available. Optional J-box inside headbox accessible via 22 ga. steel cover plate. Entire roller and drive assembly easily removable through bottom of headbox. Roller to be 6" OD x 1/8" wall steel tube. Roller brackets to be painted white and to have double row radial ball bearings. Standard or reverse roll available. Fabric stays to be installed on all shades that exceed 16' in case length. Stays will be installed at each panel seam, and across the center of each panel when panel height exceeds 54". Slat shall be 1/2" OD steel tube with black polyethylene endcaps.

Headbox constructed of extruded aluminum. Bottom of headbox fully enclosed except for slot allowing fabric passage. Bottom closure panel shall be extruded aluminum, finished white, and may be removed manually for access to roller and drive unit. Closure panel shall be held in place by screw and bracket at each end of headbox. Aluminum endplates with integrated steel brackets for suspended mounting shall be fastened to extruded headbox with thread-cutting screws. Eyebolts shall be provided for use in hoisting shade. Headbox support brackets shall be welded steel channel, riveted to exterior of headbox. Headbox shall feature a deflection compensation system to minimize fullness caused by deflection in extremely wide units. U.S. Patent No. 6,873,461.

A variety of control options are available using Draper's IntelliFlex® Control System. See control system reference sheet and planning sheet for details.

### Options:

**Wall Mount Bracket Kit:** Kit includes two structural steel brackets and hardware to attach brackets to headbox. Hardware for mounting to wall structure by others.

**Endcap Ceiling Tile Flange Kit:** Extruded aluminum, finished white. Attaches to endcaps. Each kit contains two (2) flange pieces and hardware for attaching trim flanges to endcaps.

**Ceiling Tile Flange for Front of Case:** 12' extruded aluminum, finished white. Attaches to front of headbox. Hardware for attachment to headbox included.

**Downloadable 3-part specifications are available at [www.draperinc.com](http://www.draperinc.com).**

## Please Mark Appropriate Selections

**Note Overall Opening Size:** \_\_\_\_\_

### Options and Accessories:

- Junction Box inside headbox
- Reverse Roll (Standard is fabric rolling from back of roller)
- Wall Mount Bracket Kit (Includes two brackets)
- Endcap Ceiling Tile Flange Kit (2 per kit)
- Ceiling Tile Flange for front and or rear of case (12' lengths)  
How many 12' lengths do you need? \_\_\_\_\_

### Motor Location:

- Right Hand (standard)
- Left Hand

### Control Options:

- 110-120V Wall Switch for Single Shade Control
- Low Voltage and/or Multiple Shade Control: **Please see Draper's IntelliFlex Controls Reference Sheet and IntelliFlex® Control System Planning Sheet to design a control solution for this product. The forms are available at [www.draperinc.com](http://www.draperinc.com), or by contacting Draper.**

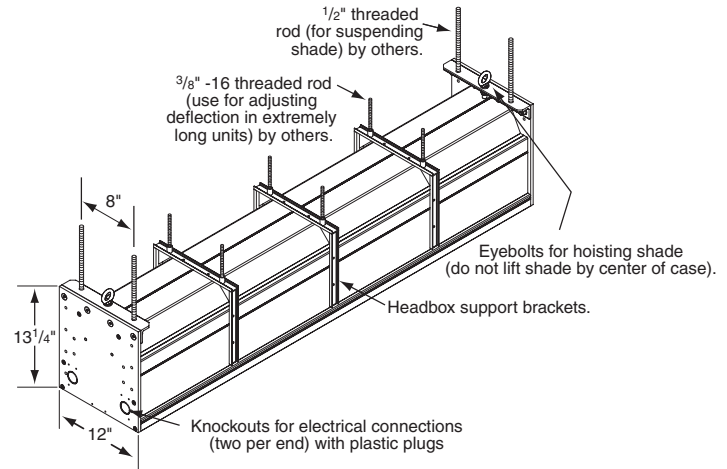

## Select Fabric, Color and Openness:\*

- CL8000 \_\_\_\_\_
- "E" Screen by Mermet \_\_\_\_\_
- Linen Veil by Newcastle \_\_\_\_\_
- "M" Screen by Mermet \_\_\_\_\_
- R1 by Mermet \_\_\_\_\_
- SheerWeave® Infinity \_\_\_\_\_
- SheerWeave® SW2000/2100 \_\_\_\_\_
- SheerWeave® SW2400/2500/2600/2900 \_\_\_\_\_
- SheerWeave® SW2700/2701 \_\_\_\_\_
- SheerWeave® SW3000 \_\_\_\_\_
- SheerWeave® SW5000 \_\_\_\_\_
- SheerWeave® SW7100 \_\_\_\_\_
- SheerWeave® PW3500/4100/4400 \_\_\_\_\_
- SheerWeave® PW4500/4600 \_\_\_\_\_
- SheerWeave® PW4550/4650 \_\_\_\_\_
- SheerWeave® PW4800 \_\_\_\_\_
- SilverScreen by Mermet \_\_\_\_\_
- Soltis 99® by Ferrari \_\_\_\_\_
- SunBloc SB9000 \_\_\_\_\_
- SunBloc SB9100 \_\_\_\_\_
- "T" Screen by Mermet \_\_\_\_\_
- Terra by Mermet \_\_\_\_\_
- Vela by Mermet \_\_\_\_\_

**\*Please see Draper's Shade Fabric Reference Sheet for fabric colors and specifications.**



411 S. Pearl St., Spiceland, IN 47385 USA ■ 765-987-7999  
[www.draperinc.com](http://www.draperinc.com) ■ fax 765-987-7142

Copyright © 2008 Draper Inc. Form ColossalFlexShade\_Sub08 Printed in U.S.A.

PROJECT: \_\_\_\_\_

ARCHITECT: \_\_\_\_\_

CONTRACTOR: \_\_\_\_\_

SUPPLIER: \_\_\_\_\_

DATE: \_\_\_\_\_ REVISED: \_\_\_\_\_

## Case Dimensions\*

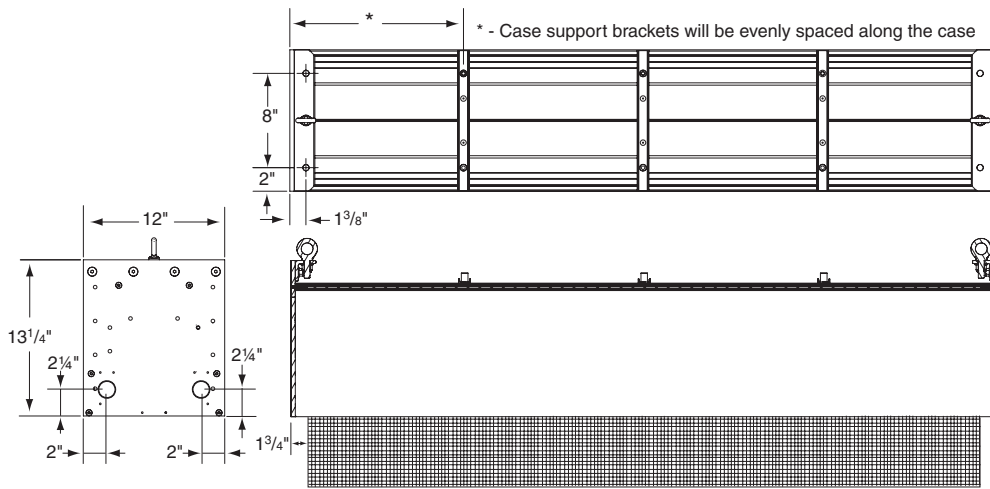

**\*Please Note: Optional wall brackets add 1 3/4" per bracket to case length. Wall mounting bracket hole location is 1" from end of case.**

## Colossal FlexShade Options—Wall Mounting Bracket and Ceiling Trim Flange

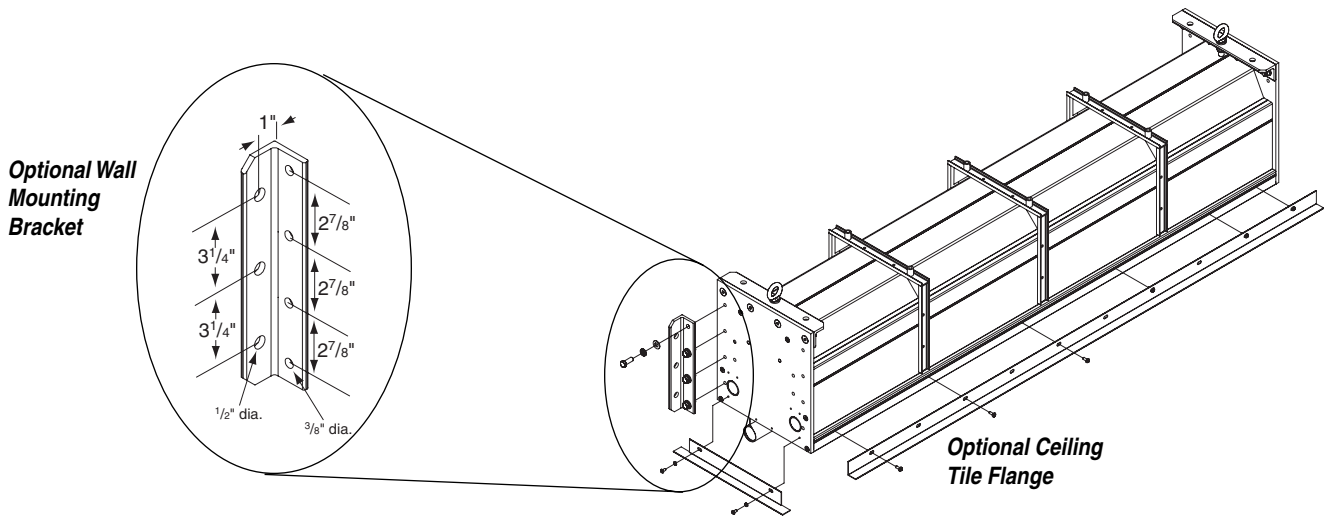

## Wiring Diagram

For multiple shade or low voltage wiring consult diagrams provided with control.

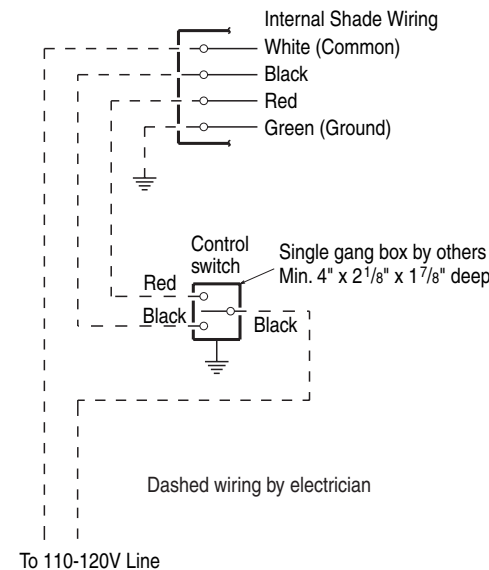

**NOTE: Test shade operation. If shade direction does not correspond with the switch orientation, turn power back off and switch the red and black wires from the motor to the switch.**