

Installation Instructions IntelliFlex™ Wall Switch by Draper

RF "Bus" Wall Switch

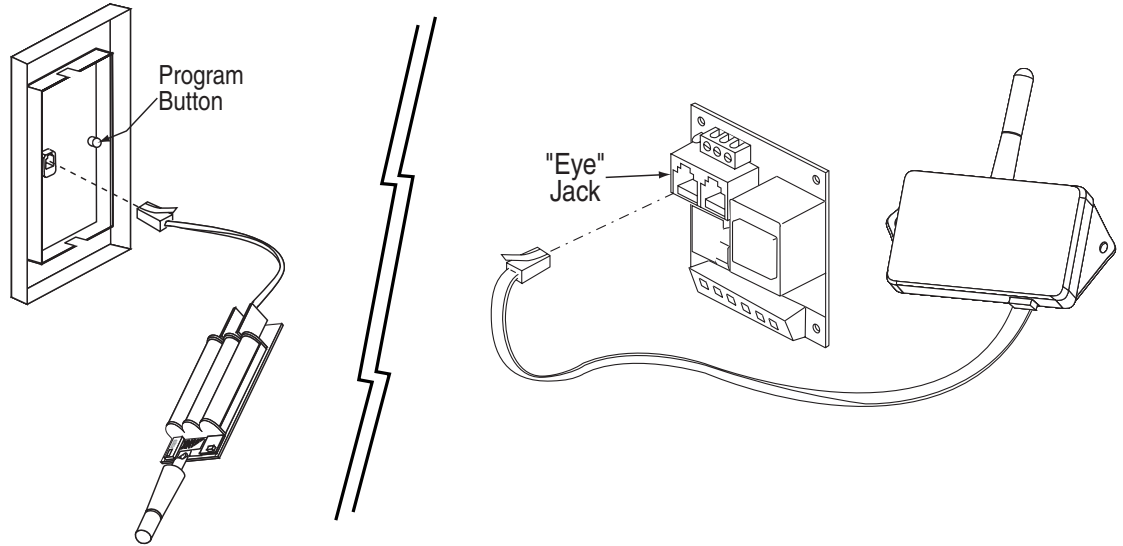

"Bus" Wall Switch

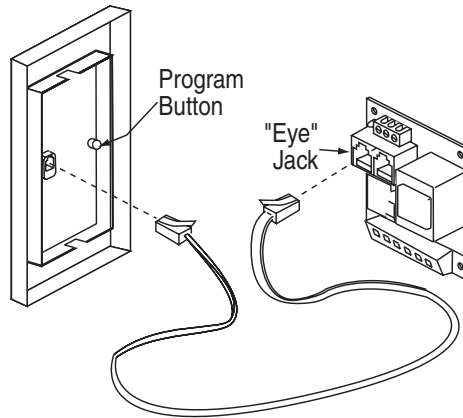

Dry Contact Wall Switch

(Switch Front/
Button Map)

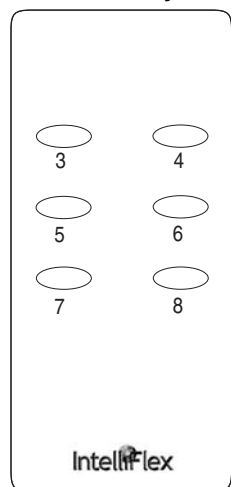

(Switch Back/
Board Map)

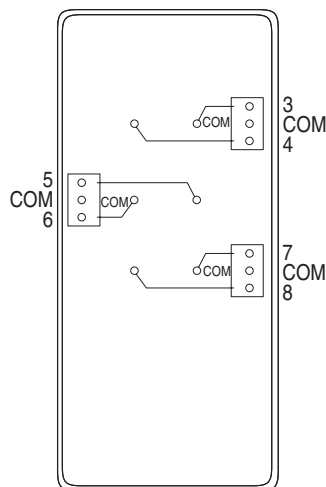

Please Note: This drawing indicates all possible connection and button locations. Your switch may not have the same number of buttons or connections, but their locations will be consistent with these "maps."

Compare your switch with these diagrams, and wire the buttons and connections on your switch accordingly.

Dry Contact switch is not programmable. Dry Contact switch can be connected to a Bus via a PSI60.

DRAPER

Please Note: For programming instructions, please see page 2.

Programming IntelliFlex Switch

Dry Contact: Does not have a Bus connection, and is not programmable. It is somewhat configurable, based on how it is connected—it must be connected directly to each device it is controlling. Can be connected to a Bus via PSI60.

RF: Battery operated. Programming the RF switch requires physical contact with the back of the switch, and allows programming of which button sends which command, along with other options. When replacing batteries, test switch to make sure it works. If not, remove batteries, wait a few seconds, then re-insert them. The switch may operate with low batteries, but programming may not work.

Programming Switch “Locally” Using IR Transmitter

Press programming button on back of switch. Red LED on back of switch will come on, indicating it is in program mode. This method uses the eye on the back of the switch, so you must use an IR transmitter for programming, and you must have access to the back of the switch. Bus commands are ignored during this process.

To set button “#” on switch to send a new “command”:

- ① Press programming mode button on back of switch (red LED appears).
- ② Press and release the switch button you want to program. The LED will change from red to green.
- ③ Press the command on the IR transmitter you want to be assigned at the button you just selected (pressing “Stop” at this point will assign the stop command to the selected button).

- ④ The LED will go back to red and you are back in program mode; e.g. to program the top left button to send Close 7: press the top left button, then press Close 7 on the IR transmitter.

Clear button “#”:

Press programming mode button on back of switch (red LED will appear). Press OPEN “#” on the IR transmitter, where “#” is the switch button number to clear. The red LED will blink off then back on, and you are back in program mode.

Reset to factory default:

Press programming mode button on back of switch (red LED will appear). Press CLOSE ALL on IR transmitter. The red LED will blink off then back on, and you are back in program mode. If this is an RF switch, the radio address will not change.

Change RF switch’s radio address:

Press programming mode button on back of switch (red LED will appear). Press Open 13 on the IR transmitter. Red LED will blink off then back on, and the radio address will be changed.

Exit programming mode:

Press STOP on the IR transmitter, and LED will turn off; or, LED will turn off automatically after 10 seconds of no IR commands or buttons pushed.

Please Note

The eye on the back of the switch is only for programming and will not act as a receiving eye.