

Installation Instructions

IntelliFlex™ Wall Entry Plate by Draper

Please Note

- ① Pre-wire one Wall Entry Plate per motor.
- ② The wire used on both the male and female terminators may be up to 12 AWG.
- ③ Be sure that wire colors on motor plug match up with wire colors running in to Wall Entry Plate.
- ④ **Make sure power is off before installing the Wall Entry Plate.**

The Wall Entry Plate (WEP) is a part that is designed to assist in the pre-wire of any sized project and allow your installer to hang the motorized window treatment and connect to a rigged and ready connection.

Wall Entry Plate Installation

- ① Supply one WEP for every motor specified at the project. Terminate, color for color, the four-conductor wire installed in the walls to the 90° plug in the plate (see Fig. 1). Use a small flat screwdriver to open the spring-loaded terminals on the plate. **Make sure the power is off before installing the Wall Entry Plate.**

Please Note: The wire used on both the male and female terminators may be up to 12 AWG.

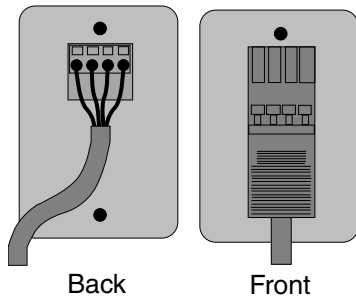

Figure 1

Hardware/Parts List

- 1—Single Gang Cover Plate (gray) with Screws & Female Plug (gray)
- 1—Male Motor Plug (gray)
- 1—Spring Clip Tool for Wiring Connections (Male Motor Plug only)
- 1—Zip Tie for Securing Sheathed Cable to Male Motor Plug Body

Motor Plug Assembly

Please Note: Each Wall Entry Plate comes with a special tool for opening the spring-loaded terminals on the Motor Plug (see Fig. 2).

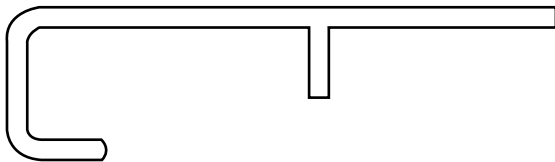

Figure 2

- ① Strip outer wire sheathing back 1", then strip insulation of individual wires back 3/8".
- ② Slide back shell onto plug (see Fig. 3).
- ③ Place plastic tool as shown in Figure 3 to open spring-loaded terminal.

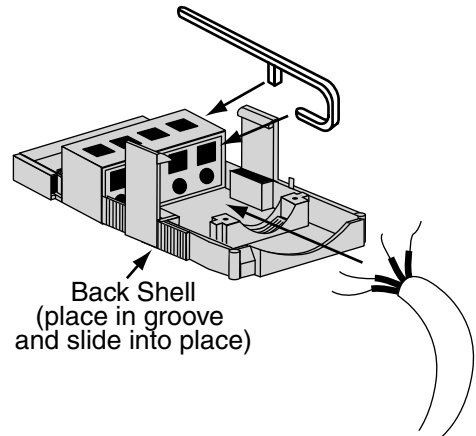

Figure 3

- ④ Insert wire into spring-loaded terminal. Move plastic tool to next terminal and repeat step three for remaining wires.

Please Note: Be sure that wire colors match up with wire colors already running in to the Wall Entry Plate.

- ⑤ Secure cable to plug body using plastic "zip tie" (included), and trim excess.
- ⑥ Once all wires are securely in place, assemble plug by snapping cap onto body of plug (see Fig. 4).

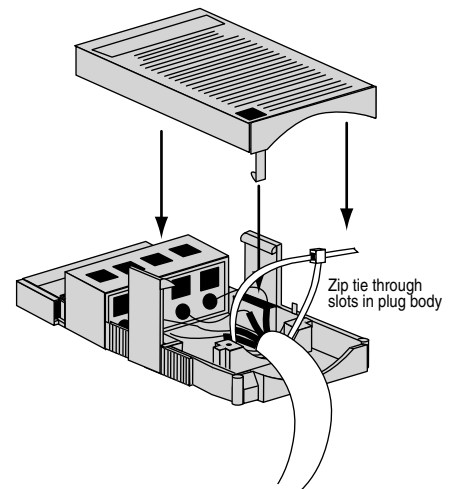

Figure 4

- ⑦ Plug motor into Wall Entry Plate.

Please Note: All operating switches should be "Off" before power is connected.

DRAPER

411 S. Pearl St., Spiceland, IN 47385 USA ■ 765-987-7999 ■ fax 765-987-7142

e-mail draper@draperinc.com ■ www.draperinc.com

Copyright ©2004 Draper Inc.

Form IntelliFlex-WallEntryPlate_Inst04

Printed in U.S.A.

If you encounter any difficulties installing/wiring your IntelliFlex Wall Entry Plate, call your dealer or Draper, Inc., Spiceland, Ind., (765) 987-7999; fax (765) 987-7142; or e-mail draper@draperinc.com.