

# Installation Instructions

## IntelliFlex™ Repeater/Timer Interface by Draper

### **Installing the Repeater/Timer Interface:**

The REP/TTI combines the features of the repeater and timer interface in one unit. It is required on all IntelliFlex™ Techniku Chronolux 4 Channel Timer installations.

A repeater can be used to solve several problems. One problem that occurs in the field is light disturbance. e.g., fluorescent lights or a lot of sunlight. This disturbance causes the eye (s) to generate noise that confuses the SC1s. This confusion is most evident when the ALL button is pushed and some of the motors start but some don't. This action is usually very inconsistent and usually goes away when the transmitter is held close to the eye.

Another problem that a repeater can solve is when there is too much wire connecting receivers together. The REP/TTI can easily drive 1000 feet of modular cable.

### **General rules:**

- ① There should only be one REP/TTI in a given system.
- ② The REP/TTI must connect to an "Eye" port on an SC1 (see Fig. 1).
- ③ ALL eyes in the system must be connected to the "Eye" port on the REP/TTI, and there must NOT be any eyes connected directly to any of the receivers.

- ④ The eye must be placed so that it can "see" the Techniku Chronolux Timer. This generally means to the left, right or above the timer on the same wall, or looking at the timer from the opposite wall. Below or behind the timer is least optimal placement, and the eye will have to be much closer for it to work correctly.

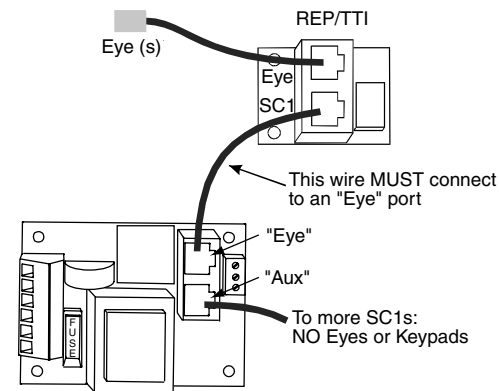

Figure 1

**Please Note:** Please consult appropriate separate instruction sheets for information on installing devices to be connected using the Repeater/Timer Interface.

# DRAPER

411 S. Pearl St., Spiceland, IN 47385 USA ■ 765-987-7999 ■ fax 765-987-7142  
e-mail draper@draperinc.com ■ www.draperinc.com

Copyright ©2004 Draper Inc. Form IntelliFlex-Rep-TimerInterface\_Inst04 Printed in U.S.A.

If you encounter any difficulties installing/wiring your IntelliFlex Repeater-Timer Interface, call your dealer or Draper, Inc., Spiceland, Ind., (765) 987-7999; fax (765) 987-7142; or e-mail draper@draperinc.com.