

Installation/Operating Instructions

Colossal FlexShade by Draper

Caution

- ① Read instructions through completely before proceeding.
- ② Follow instructions carefully. Installation contrary to instructions invalidates warranty.
- ③ Pick up shade from **ends only**. Picking headbox up at other points **will damage case** and **may damage fabric**.
- ④ Entire bottom of shade headbox should be unobstructed to permit access to bottom panel for making electrical connections or servicing.
- ⑤ Shade should be installed level (using a carpenter's level).
- ⑥ Operating switch(es) packed separately in shade carton. Do not discard with packing material.
- ⑦ Shade operates on 110-120V, 60 Hz. current.

NOTE: Shade has been thoroughly inspected and tested at factory and found to be operating properly prior to shipment.

Mounting Shade

Regardless of mounting method used, the following points apply:

- ① Shade should be lifted into position **only by the end mounting brackets**. **Draper provides eyebolts to use in hoisting the shade. Never attempt to lift shade along its length.**
- ② Shade should be positively and securely supported so that vibration or even abusive pulling will not weaken installation.
- ③ Installer must insure that fasteners used are of adequate strength and suitable for the mounting surface chosen. **Installer must also insure that wall or ceiling structure are of adequate strength.** Supporting hardware (chains, cables, rods, etc.) must be essentially vertical.
- ④ Entire bottom of headbox must be readily accessible after installation is complete.
- ⑤ Front, back and top of case must be straight—not forced to warp or bow. Adjust spreader bars to keep large cases from warping.
- ⑥ Do not use headbox to support adjacent sections of ceiling.
- ⑦ If optional ceiling flange trim kits are attached, use hardware provided.
- ⑧ If headbox is painted, slots on bottom of case should be shielded to protect viewing surface from paint splatters or overspray.
- ⑨ After the headbox is mounted, and before the shade is operated, you will need to remove the shipping brackets from inside the headbox. First, remove the closure panel (see instructions on page 2). You will find the shipping brackets on the motor-end endcap—one in front of the roller and one behind (see Fig. 1). Remove the black hexagonal brackets with a wrench, taking care not to damage the fabric or loosen the wiring (see caution note below). Replace the closure panel.

Caution: Shade is shipped with motor wiring mounted to the headbox. Be careful not to pull the wiring loose from the headbox while removing the brackets—if wiring is loose, it could be damaged during shade operation. If wiring does come loose, re-mount as it was.

- ⑩ Do not seal unit in ceiling until electrical connections have been made and shade has been operated successfully.



Figure 1 (roller and fabric removed for clarity)

Electrical Connections

Shade operates on 110-120V, 60 Hz. current.

Junction box is located just above the closure panel, at the motor end of shade. To properly remove closure panel, two people should follow the steps on page two of these instructions. The junction box access plate is held closed with pan head screws and may be opened with a Phillips screwdriver. Removal of access plate exposes red, black and white pigtail leads and green internal ground wire per wiring diagram attached.

Shade is shipped with internal wiring complete and control switch(es) fully boxed. Wire connecting shade to switch(es) and switch(es) to power supply should be furnished by installer. Connections should be made in accordance with attached wiring diagram, and wiring should comply with national and local electrical codes.

All operating switches should be "off" before power is connected.

Please Note: For low voltage wiring requirements, Draper recommends consulting with a professional low voltage electrical contractor. It is very important that shielded and stranded CAT 5 cable be used to prevent any electrical interference.

Operation

When shade is first operated, **be cautious!** Cycle unit down and up several times to confirm satisfactory operation.

Adjustments

Shade has been factory set and should not normally require further adjustment. However, if you desire to change the "up" and "down" stopping positions, proceed as follows:

CAUTION: Be sure all switches are in "off" position before adjusting limit switches. Always be prepared to shut shade off manually when new adjustment is being tested. Shade may be severely damaged if allowed to run too far up or too far down.

ADJUSTING "FULLY UP" POSITION—Put a small screw driver in the groove of the yellow button on the motor and press vertically until hearing a "click". Raise the shade by pressing the "up" switch on unit. Press the "stop" switch when the shade is at the desired position. Then press the yellow button on motor until you hear a "click", then release.

ADJUSTING "FULLY DOWN" POSITION—Put a small screw driver in the groove of the white button on the motor and press vertically until hearing a "click". Lower the shade by pressing the "down" switch on unit. Press the "stop" switch when the shade is at the desired position. Then press the white button on motor until you hear a "click", then release.

AT NO TIME SHOULD SHADE BE UNROLLED ENOUGH TO EXPOSE ANY PART OF SHADE ROLLER.

Please Note: The above instructions affect only the limits on the motors. For adjustment procedures using Draper's IntelliFlex Control Systems, please consult the installation information for the appropriate control.

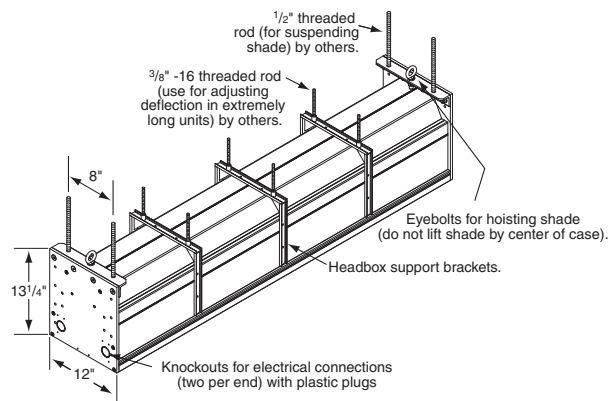

Caution: Do not remove the roller assembly from the case unless necessary for repairs. If the roller assembly is removed, be sure motor is fully re-sprung in the bracket, and re-secure it carefully with the motor retaining spring and screw (see diagram below).

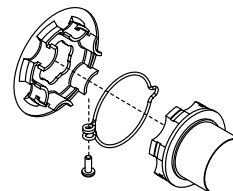

Please note: Maximum torque for tightening screw is 5 lb-inches.

DRAPER®

411 S. Pearl St., Spiceland, IN 47385 USA ■ 765-987-7999
www.draperinc.com ■ fax 765-987-7142

Please see back page for dimensional diagrams of case and optional wall mounting bracket, wiring diagrams and instructions on removing and replacing the bottom closure.

If you encounter any difficulties installing or servicing your Colossal FlexShade, call your dealer or Draper, Inc., Spiceland, Indiana, (765) 987-7999 or fax (765) 987-7142.

Optional Wall Mounting Bracket

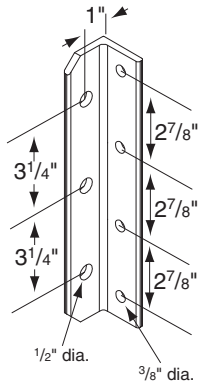

Dimensions*

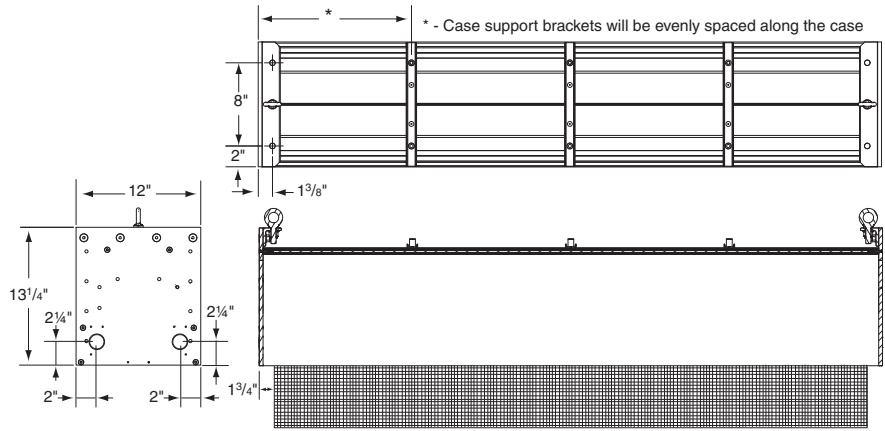

Bottom Closure Removal/Replacement

Removal and replacement of the bottom closure panel requires two people. Closure should be handled as shown in Step 5 below to prevent bowing of the closure during handling.

Before removing bottom closure, you must first remove brackets at each end of case (see drawing at right).

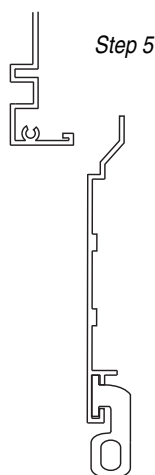
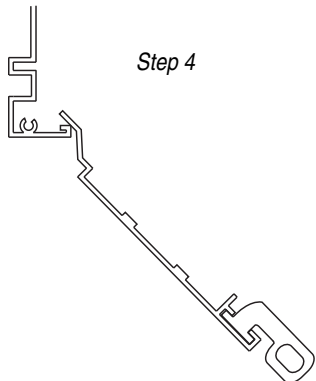
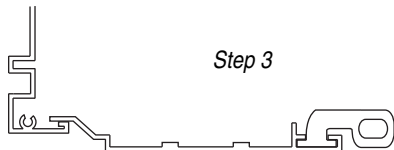
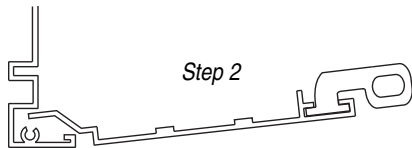
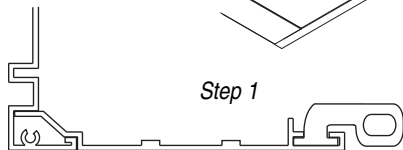
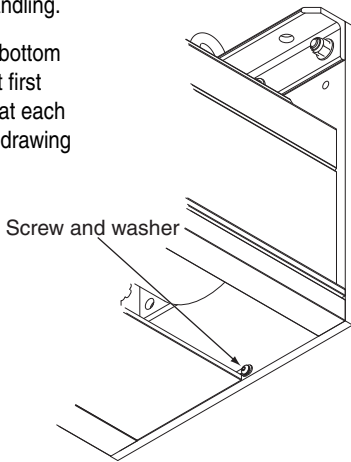

***Please Note: Optional wall brackets add 1 1/4" per bracket to case length. Wall mounting bracket hole location is 1" from end of case.**

Wiring Diagrams

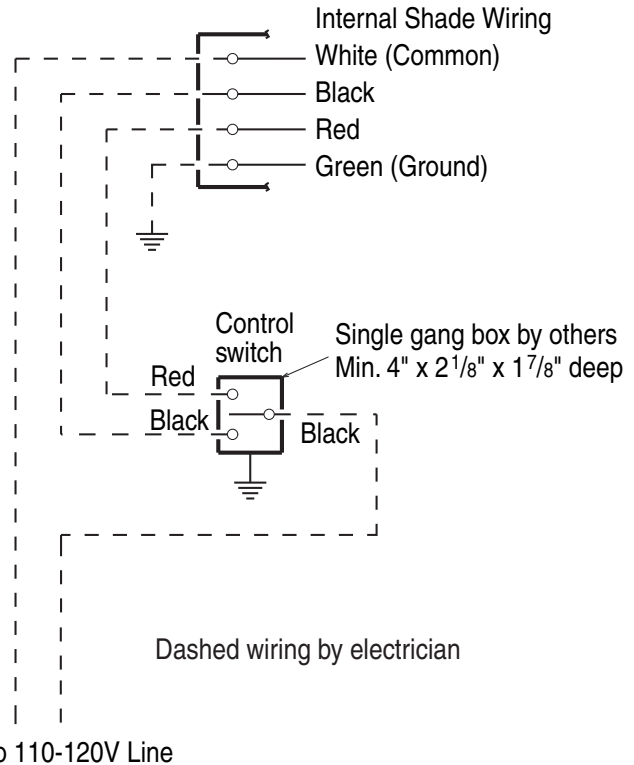

NOTE: Test shade operation. If shade direction does not correspond with the switch orientation, turn power back off and switch the red and black wires from the motor to the switch.

Cleaning and Maintenance

Idlers on motorized shades may occasionally need lubrication. If lubrication is required, apply a small amount of a lithium based grease direct to the idler pin.

Most of Draper's standard fabrics may be cleaned at the window by vacuuming with a soft brush attachment. They may also be cleaned by using a sponge or soft cloth and mild solution of warm soapy water. A dishwashing liquid, such as Ivory liquid, is recommended. A clean dry cloth is recommended for the metal finish. **Exceptions are Flocké, Roc-Rol and Phifer SW7000 fabrics, which must be cleaned with a dry art sponge.**