

Revelation

Stationary, Ceiling-Recessed Mount
for single lens projector

by DRAPER

Specifications—Revelation

_____ Revelation (Model A/Model B) video projector mount (s) for projectors weighing up to 100 lbs. Projector to rest in a pan to be mounted permanently above the ceiling. Overall size to be (Model A—13" x 38¹/₄" x 34") (Model B—13" x 38¹/₄" x 44").

From room side, only visible part to be operating door finished in white baked textured powder coat. Can be installed to match a 24" x 24" ceiling grid spacing or used with reveal style grid ceilings. Door to lower smoothly into audience room to preset point: approximately a 45° angle to the ceiling—a vertical distance of approximately 17". Factory set limit switches to automatically stop door travel at open and closed positions.

Unit's electrical box to include one, continuously energized, 60 hz, 110-120v AC, fused outlet. Unit to be furnished with holes for cable passages. 3-position low voltage control switch to stop or reverse cycle at any point. Door to be electrically operated 60 hz, 110-120v AC. Motor to be UL recognized, instantly reversible, and lifetime lubricated. Draws 1 amp (does not include

any load placed on internal outlet).

Door to contain first surface optical grade 6 mm glass mirror, 94% reflective. A second identical mirror to be mounted in pan above ceiling. Mirrors to work in tandem to reflect projected light onto a wall or ceiling mounted Draper projection screen. U.S. Patent Number 6,379,012.

Options

Environmental Airspace Housing: Aluminum, suitable for use in Environmental Airspace. Housing to have intake and exhaust fan system with 4" couplers for connection to remote ventilation duct work.

Ceiling Access Door (2' x 2'): Provides access to projector and lift when unit is installed above hard ceiling.

Glass Shield: Can be installed with unit or later to an existing unit, to further reduce projector noise.

Downloadable 3-part specifications are available at www.draperinc.com.

Please Check All Appropriate Selections

Select Model:

- Model A
- Model B

Select Options:

- Environmental Airspace Housing
- Ceiling Access Door
 - Ceiling access door, white painted finish
 - Ceiling access door, accepts ceiling tile
- Glass Shield

Select Controls:

- Standard—Single Station Control—12v AC
- Optional—Multiple Station Control—24v DC
 - Specify number of stations _____
 - Wireless Remote Control (Infrared transmitter & receiver)
 - Wireless Remote Control (Radio Frequency transmitter & receiver)
- Optional—Key-Operated Power Supply Control Switch
- Optional—Video Interface Control For Projection Screen Operation (VIC-12 Kit for Revelation)

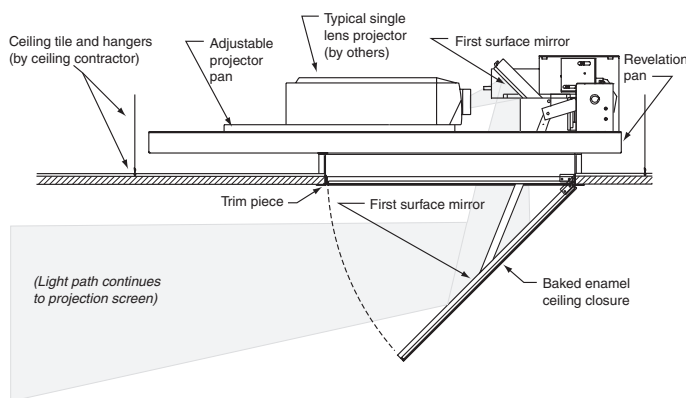

Revelation Dimensions & Data	Model A	Model B
Overall Unit Size (HWL)	13" x 38 ¹ / ₄ " x 34"	13" x 38 ¹ / ₄ " x 44"
Required Space Above Ceiling*	13 ⁵ / ₈ " x 38 ¹ / ₄ " x 34"	13 ⁵ / ₈ " x 38 ¹ / ₄ " x 44"
Clearance Below Ceiling	approx. 17"	approx. 17"
Rough Ceiling Opening for motorized door	23 ¹ / ₂ " x 23 ¹ / ₂ "	23 ¹ / ₂ " x 23 ¹ / ₂ "
Capacity	100 lbs.	100 lbs.
Door's Downward Travel Distance	approx. 17"	approx. 17"
Travel Time	9 sec.	9 sec.
Net Weight	85 lbs.	90 lbs.
Shipping Weight	215 lbs.	220 lbs.

Projector Space (HWL)—To fit within parameters of inner pan.

* 13⁵/₈" is overall height of Revelation with Environmental Airspace housing (13" WITHOUT Environmental Airspace housing).

Electrical Specifications

Operating Voltage	110–120 VAC 50–60 Hz
Amperes	1 Amp**
Control Voltage	12 VAC

Motor Specifications:

Voltage	110–120 VAC 50–60 Hz
Amps	.43
Torque	200 IN–lbs.

** Does not include any load placed on internal outlet.

U.S. Patent Number 6,379,012

DRAPER®

411 S. Pearl St., Spiceland, IN 47385 USA ■ 765-987-7999
www.draperinc.com ■ fax 765-987-7142

Copyright © 2009 Draper Inc. Form Revelation_Sub09 Printed in U.S.A.

PROJECT: _____

ARCHITECT: _____

CONTRACTOR: _____

SUPPLIER: _____

DATE: _____ REVISED: _____

Revelation Dimensions & Wiring Diagrams

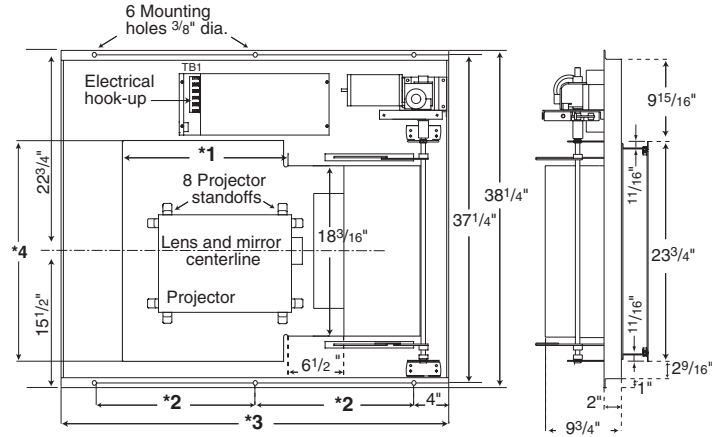

	Model A	Model B
*1	9 1/8"	18 11/16"
*2	13"	18"
*3	34"	44"
*4	21 1/2"	24 13/16"

Minimum rough opening
23 1/2" x 23 1/2"

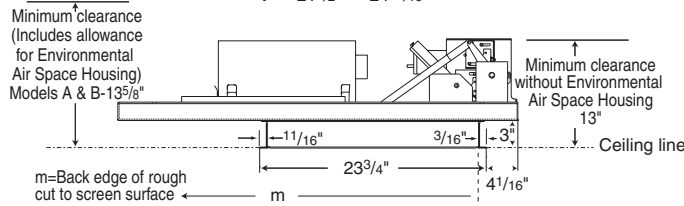

Wiring Diagrams for Revelation without Environmental Airspace Housing Single Station Control

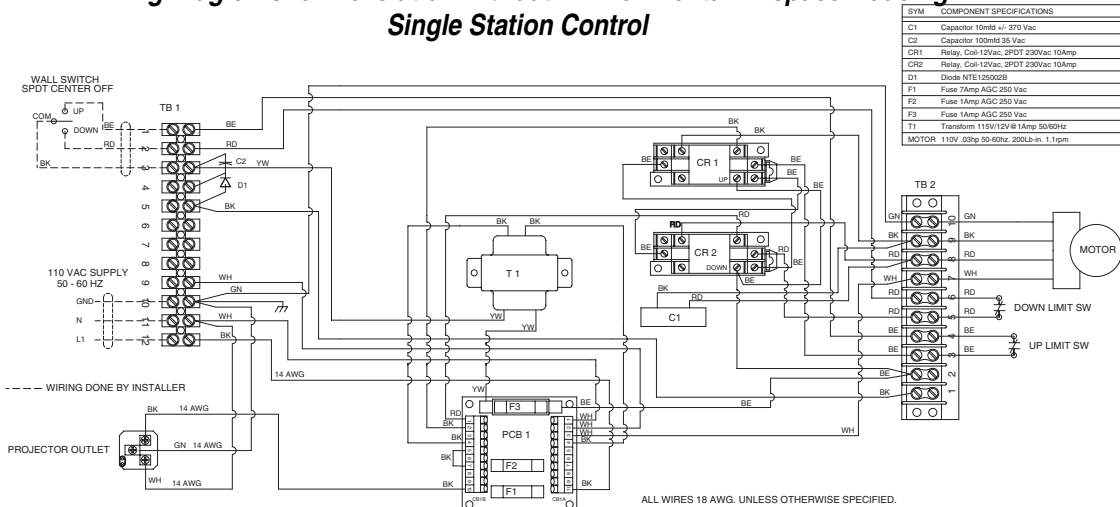

SYM	COMPONENT SPECIFICATIONS
C1	Capacitor 10mfd +/- 370 Vac
C2	Capacitor 100mfd 35 Vac
CR1	Relay, Coil 12Vac, 2PDT 230Vac 10Amp
CR2	Relay, Coil 12Vac, 2PDT 230Vac 10Amp
D1	Diode NTE120028
F1	Fuse 7Amp AGC 250 Vac
F2	Fuse 1Amp AGC 250 Vac
F3	Fuse 1Amp AGC 250 Vac
T1	Transformer 115V/12V/48 1Amp 50/60Hz
MOTOR	110V @3hp 50-60hz 200Lb-in. 1.1pm

Low Voltage Multiple and Remote Control

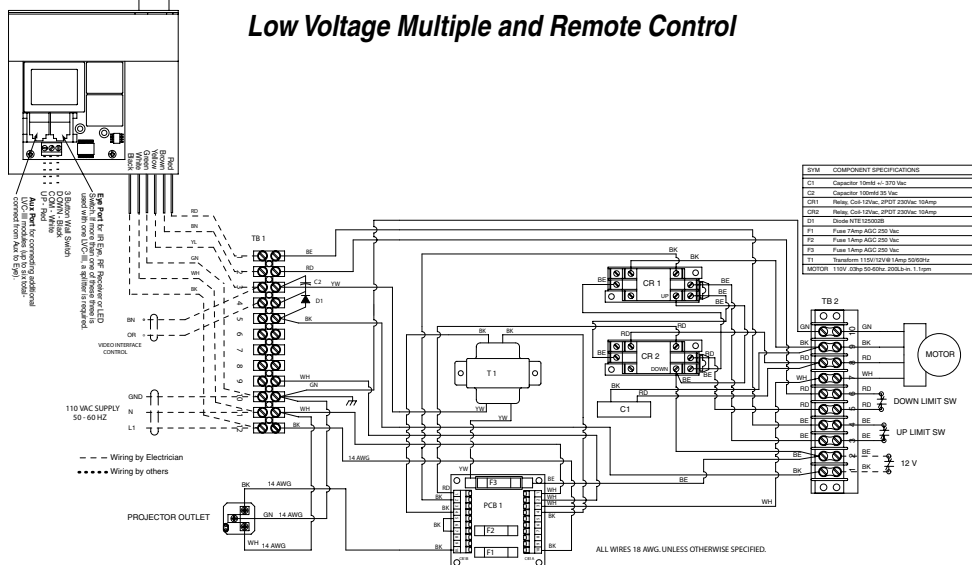

SYM	COMPONENT SPECIFICATIONS
C1	Capacitor 10mfd +/- 370 Vac
C2	Capacitor 100mfd 35 Vac
CR1	Relay, Coil 12Vac, 2PDT 230Vac 10Amp
CR2	Relay, Coil 12Vac, 2PDT 230Vac 10Amp
D1	Diode NTE120028
F1	Fuse 7Amp AGC 250 Vac
F2	Fuse 1Amp AGC 250 Vac
F3	Fuse 1Amp AGC 250 Vac
T1	Transformer 115V/12V/48 1Amp 50/60Hz
MOTOR	110V @3hp 50-60hz 200Lb-in. 1.1pm