

# Installation Instructions

## Accuset Component Kit for LCD/DLP Projectors by Draper

### **Caution**

- ① Installer must make sure Accuset Mount for LCD/DLP Projectors is positively and securely attached, and appropriate fasteners are used.
- ② Before installing, check to make sure all parts of the mount are there.
- ③ Assembly hardware is included; fasteners for attaching mount to ceiling are not included.
- ④ Make sure all screws and bolts are tightened before allowing Accuset Mount for LCD/DLP Projectors to bear the full weight of the projector.
- ⑤ Mount projector before hooking up to electrical and other cables.
- ⑥ When making adjustments, make sure projector is firmly supported.
- ⑦ Adjustment setscrews require Metric Allen wrench (included).
- ⑧ Assembly screws require Torx Head drive (included).

### **Installation—Adjustable (See Fig. 1)**

- ① Screw Outer Column (2" NPT pipe) into Ceiling Plate.
- ② Attach Positive Stop to upper end of Inner Column, then slide Inner Column down through Extension Adapter. Tighten Extension Adapter using two 10-32 x 5/8" torx screws and #10 washers.
- ③ Install Extension Adapter and Inner Column assembly to Outer Column. Secure with one 10-32 x 5/8" torx screw. For increased security, replace the standard screw with a security screw (provided).
- ④ Attach Bracket Adapter and Ball Joint Assembly to Inner Column and secure with provided screw. For increased security, replace the standard screw with a security screw (provided). For additional security, remove the three standard screws holding the Ball Joint in the Bracket Adapter, and replace with provided security screws. You can also replace the adjustment screws in the Extension Adapter with provided security screws.
- ⑤ Use ceiling plate to mark ceiling.
- ⑥ If appropriate, run cabling down through pipe and out through opening in Bracket Adapter.
- ⑦ Attach plate to ceiling. If using optional Angled Mounting Plate, attach Ceiling Mounting Plate to Angled Mounting Plate using 1/4"-20 x 5/8" long hex head screws (provided), then attach Angled Ceiling Mounting Plate to ceiling (hardware for ceiling attachment not included).
- ⑧ Install Universal Projector Bracket on projector if applicable (see separate instructions). Then, attach bracket and projector to Accuset ball joint. Adjust as necessary (see Fig. 3).

### **Installation—Fixed (See Fig. 2)**

- ① Screw column (1 1/2" NPT pipe) into Ceiling Plate.
- ② Attach Bracket Adapter and Ball Joint Assembly to column and secure with provided screw. For increased security, replace the standard screw with a security screw (provided). For additional security, remove the three standard screws holding the Ball Joint in the Bracket Adapter, and replace with provided security screws.
- ③ Use ceiling plate to mark ceiling.
- ④ If appropriate, run cabling down through pipe and out through opening in Bracket Adapter.
- ⑤ Attach plate to ceiling. If using optional Angled Mounting Plate, attach Ceiling Mounting Plate to Angled Mounting Plate using 1/4"-20 x 5/8" long hex head screws (provided), then attach Angled Ceiling Mounting Plate to ceiling (hardware for ceiling attachment not included).
- ⑥ Install Universal Projector Bracket on projector if applicable (see separate instructions). Then, attach bracket and projector to Accuset ball joint (see Fig. 3).

**Please note: To adjust height, loosen two adjustment screws in Extension Adapter, retract or extend the inner column, and re-tighten adjustment screws.**

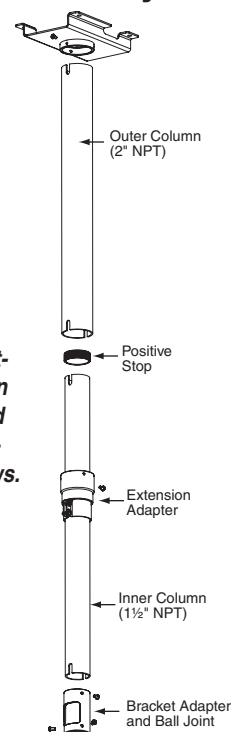
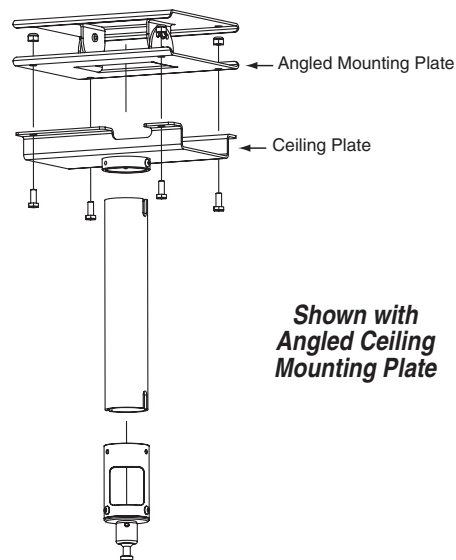

Figure 1



**Shown with Angled Ceiling Mounting Plate**

Figure 2

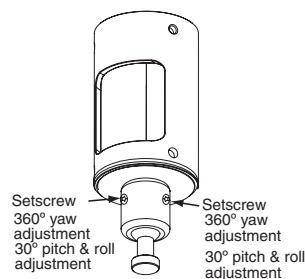

Figure 3

**Continued on Back**

# DRAPER

411 S. Pearl St., Spiceland, IN 47385 USA ■ 765-987-7999 ■ fax 765-987-7142  
 e-mail draper@draperinc.com ■ www.draperinc.com

Copyright ©2006 Draper Inc.

Form AccusetComponent\_Inst06

Printed in U.S.A.

*If you encounter any difficulty installing or servicing your Accuset Mount for LCD/DLP Projectors, call your dealer or Draper, Inc., Spiceland, Indiana, (765) 987-7999; fax (765) 987-7142; or e-mail draper@draperinc.com.*

## Installation—Bracket Adapter Only (See Fig. 4)

- ① Attach Bracket Adapter and Ball Joint Assembly to column (1½" NPT pipe) and secure with provided screw. For increased security, replace the standard screw with a security screw (provided). For additional security, remove the three standard screws holding the Ball Joint in the Bracket Adapter, and replace with provided security screws.
- ② If appropriate, run cabling down through pipe and out through opening in Bracket Adapter.
- ③ Install Universal Projector Bracket on projector if applicable (see separate instructions). Then, attach bracket and projector to Accuset ball joint (see Fig. 6).

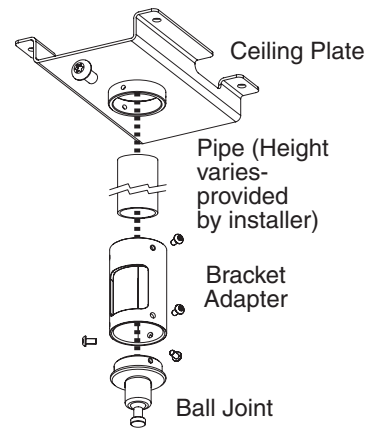

Figure 4

## Installation—Flush Extension (See Fig. 5)

- ① Screw Flush Extension into Ceiling Plate.
- ② Attach Bracket Adapter and Ball Joint Assembly to Flush Extension and secure with provided screw. For increased security, replace the standard screw with a security screw (provided). For additional security, remove the three standard screws holding the Ball Joint in the Bracket Adapter, and replace with provided security screws.
- ③ Use ceiling plate to mark ceiling.
- ④ If appropriate, run cabling down through Flush Extension and out through opening in Bracket Adapter.
- ⑤ Attach plate to ceiling. If using optional Angled Mounting Plate, attach Ceiling Mounting Plate to Angled Mounting Plate using ¼"-20 x 5/8" long hex head screws (provided), then attach Angled Ceiling Mounting Plate to ceiling (hardware for ceiling attachment not included).
- ⑥ Install Universal Projector Bracket on projector if applicable (see separate instructions). Then, attach bracket and projector to Accuset ball joint (see Fig. 6).

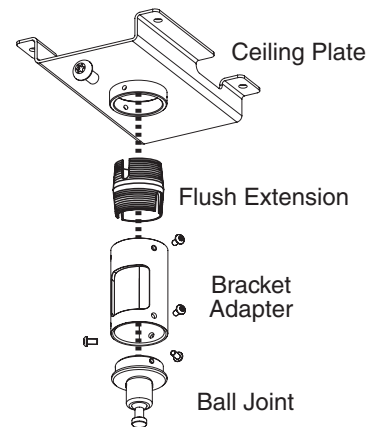

Figure 5

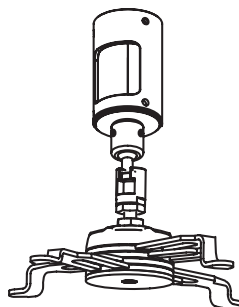

Figure 6