

Hardware for FlexShades

Type D Pocket—An extruded aluminum pocket for clean, ceiling flush installation. With bottom closure panel in place, only a narrow slot is visible. Aluminum pockets offer a convenient architectural solution for mounting either **MOTORIZED** or **MANUAL FLEXSHADES** at the curtain wall.

Installation of **TYPE D POCKET** in coordination with ceiling finishing allows for later installation of shades. Pockets are finished in white. **FLEXSHADES** are installed using standard ceiling brackets.

DRAPER'S TYPE D POCKET cross-section dimensions are $4\frac{1}{2}$ " deep x $4\frac{5}{8}$ " high. Comes in 12' lengths. A tile-support flange along lower edge supports lay-in ceiling. Pre-welded corners and pocket ends are available. Endcaps optional. Add $\frac{1}{4}$ " to overall case width if using endcaps.

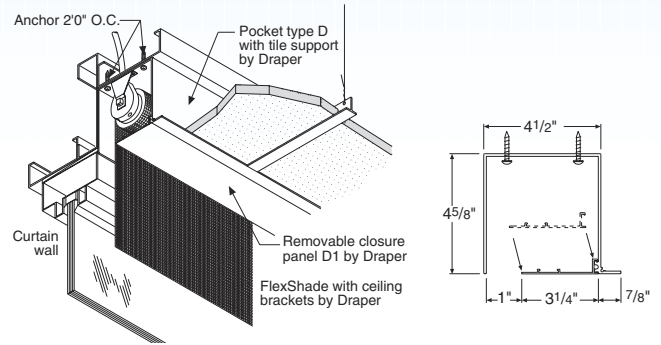

Graphic FlexShades

Virtually any logo or image

You provide the artwork, and **DRAPER** will print your logo or graphic. We use a high quality, digital four-color process to assure a crisp and clear image.

- Ideal when restrictions are imposed on signage.
- Put your logo or ad on the side of the shade facing out, and display it to the world.
- Graphic can be printed on either side of shade.
- See your **DRAPER** representative for restrictions and available fabrics.

For more information:

www.draperinc.com/go/ShadeGraphics.htm.

Graphic FlexShades with SheerWeave® PW3500 fabric at The Joan Weill Center for Dance (formerly Ailey American Dance Theater). Architects: Iu + Bibliowicz Architects LLP. Photography: © 2005 Bruce Katz. All located in New York, NY.



Graphic FlexShades with Soltis® 99 fabric at University of Missouri, Columbia. Architect: Hastings & Chivetta Architects, Inc., St. Louis, MO. Installation: Jack F. Dale & Associates. Photography: © Emily Bach, Columbia, MO.