

EZ Fold® TS-22

Basketball Backstop—Ceiling-Suspended,
Stationary, Wall-Braced

by **DRAPER**

1. Superstructure supplied for existing conditions.
2. Contact Draper for Dimension A.

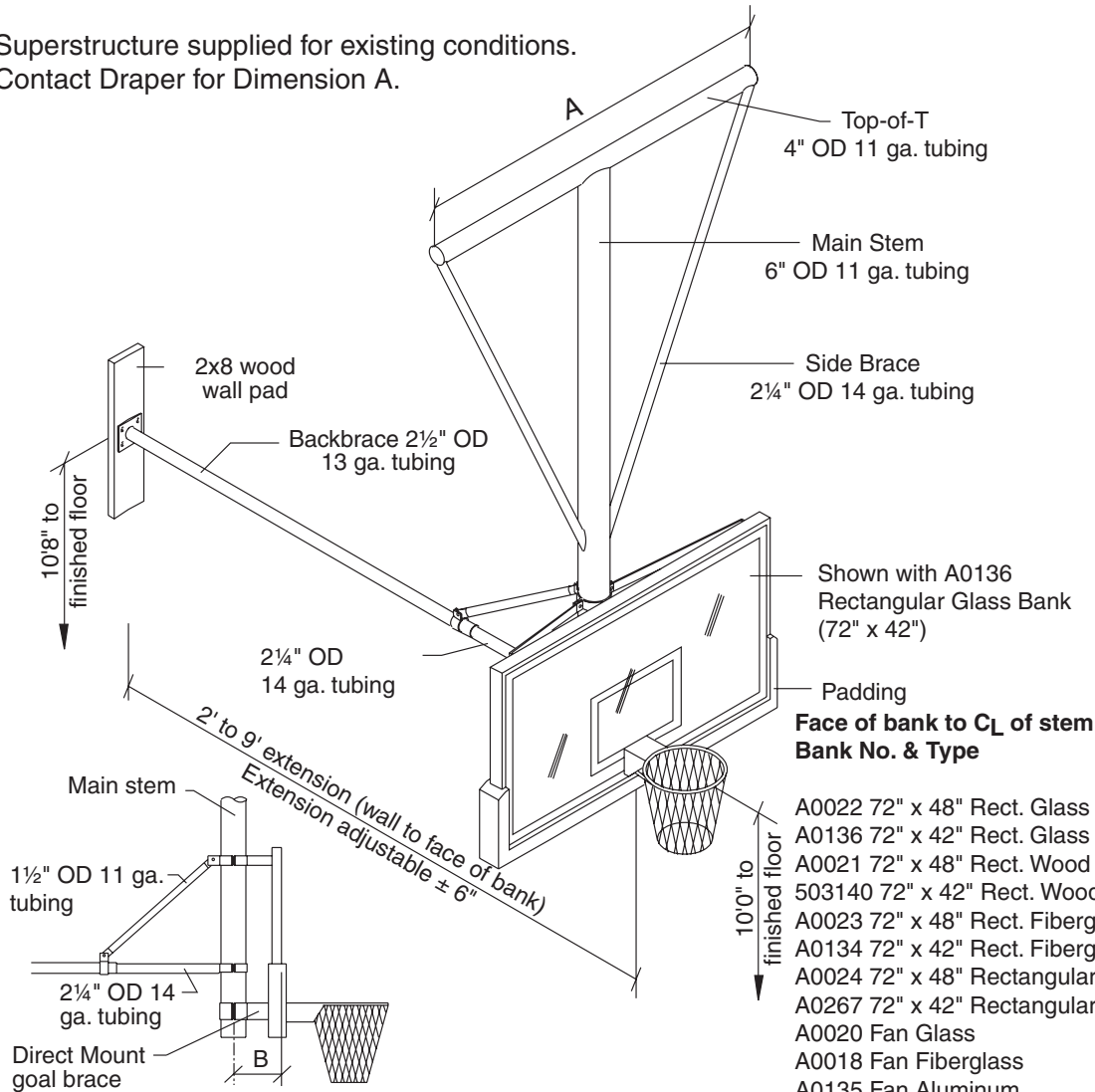

Face of bank to CL of stem Bank No. & Type	Dim. B w/o Ht. Adj	Dim B w Ht. Adj
A0022 72" x 48" Rect. Glass	11 ¹ / ₄ "	11 ¹⁵ / ₁₆ "
A0136 72" x 42" Rect. Glass	11 ¹ / ₄ "	11 ¹⁵ / ₁₆ "
A0021 72" x 48" Rect. Wood	11 ¹ / ₈ "	11 ³ / ₁₆ "
503140 72" x 42" Rect. Wood	10 ⁹ / ₁₆ "	11 ¹ / ₄ "
A0023 72" x 48" Rect. Fiberglass	10 ¹ / ₂ "	11 ³ / ₁₆ "
A0134 72" x 42" Rect. Fiberglass	10 ¹ / ₂ "	11 ³ / ₁₆ "
A0024 72" x 48" Rectangular Steel	10 ¹ / ₂ "	11 ³ / ₁₆ "
A0267 72" x 42" Rectangular Steel	10 ¹ / ₂ "	11 ³ / ₁₆ "
A0020 Fan Glass	11"	11 ¹³ / ₁₆ "
A0018 Fan Fiberglass	10 ¹ / ₂ "	11 ³ / ₁₆ "
A0135 Fan Aluminum	10 ³ / ₁₆ "	10 ⁷ / ₈ "

Side View/Goal Brace Detail

"Goal Brace" feature attaches directly behind goal mounting plate and directly to main stem of backstop, which eliminates strain on backboards.

Draper offers a 25-year limited warranty on the EZ Fold basketball backstop structure. No other basketball backstop manufacturer offers you this protection. For a copy of the EZ Fold backstop warranty in its entirety, contact Draper, Inc.

DRAPER

411 S. Pearl St., Spiceland, IN 47385 USA ■ 765-987-7999
www.draperinc.com ■ fax 765-987-7142

Copyright © 2007 Draper Inc. Form EZ-TS-22_Sub07 Printed in U.S.A.

PROJECT: _____

ARCHITECT: _____

CONTRACTOR: _____

SUPPLIER: _____

DATE: _____ REVISED: _____

Specifications—EZ Fold TS-22

Ceiling-Suspended, Stationary Backstop (Under 28'4" only)

Product Description

Basketball backstop shall be the EZ FOLD Model TS-22, ceiling-suspended, stationary by Draper, Inc. of Spiceland, IN.

Backstop shall be a welded together main frame constructed from steel mechanical tubing to form a rigid tetrahedral "T" design of back-to-back right triangles. The main stem (center strut) shall be 6" OD 11-gauge steel tubing, the top of the "T" shall be 4" OD 11-gauge steel tubing, and the side braces shall be 2¼" OD 14-gauge steel tubing. Side braces shall join stem no higher than 4'6" above goal. The main stem shall be of sufficient length to allow plus or minus 6" height adjustment of either fan or rectangular banks.

The backbrace shall be fully adjustable, and constructed of 2½" OD 13-gauge (outer) steel tubing and 2¼" OD 14-gauge (inner) steel tubing.

The backstop shall be supported from 4" OD 11-gauge steel mechanical tubing (as shown on plans) anchored to roof structure by means of heavy steel support hangers. Superstructure tubes shall be reinforced with bridging and/or bracing when truss centers exceed 8'0".

The bank shall be attached to the 6" OD main stem by heavy-duty bank hangers. Hangers shall be constructed of 2¼" OD 14-gauge steel tubing and ¼" x 2" flat steel plate with slotted holes for lateral adjustment. All glass banks shall have one upper bank hanger and include a goal brace which attaches directly to the goal mounting plate and directly to the 6" main stem of the backstop to eliminate strain on the bank and help prevent glass breakage. This direct mount feature shall conform to NCAA recommendation No. 5-F (dated Mar. 82) which states that the design of the unit shall transfer the load on the goal directly to the backboard support so as to minimize stress to the glass backboard.

Backstop shall have a black or white powder coat finish. Other colors optionally available: contact Draper for details.

Options

Backstop can be provided with any of several different styles of backboards, goals and padding. Specify types desired. See separate sheets.

Accessories

Height Adjusters (see separate sheets):

- 503093**— For motorized 8'-10' height adjustment of rectangular bank.
- 503097**— For motorized 8'-10' height adjustment of fan bank.
- 503095**— For motorized 8'-10' height adjustment of rectangular bank with wireless remote control.
- 503098**— For motorized 8'-10' height adjustment of fan bank with wireless remote control.
- 503096**— For motorized 8'-10' height adjustment of rectangular bank with EZ Stick Power Wand.
- 503099**— For motorized 8'-10' height adjustment of fan bank with EZ Stick Power Wand.
- 503092**— For manual 8'-10' height adjustment of rectangular backboards.
- 503094**— For manual 8'-10' height adjustment of fan backboards.
- 503003—Portable Height Adjuster Operator**—Speed controlled battery powered operator for manual height adjusters. For complete specifications, see separate sheet.

LEED® Submittal Information

Credit	Measure	
MRc4 – Recycled Content	Post Consumer Average 51.21%	Post Industrial 0%
MRc5 – Regional Materials	Product Manufactured in Spiceland, IN 47385 or Malta, OH 43758	

**Downloadable 3-part specifications
are available at www.draperinc.com.**