

EZ-Fold® SW

Basketball Backstop—
Wall-Mounted, Stationary

by **DRAPER**

Style of Bank	Without Height Adjuster			With Height Adjuster		
	Dimension A	Dimension B	Spread	Dimension A	Dimension B	Spread
Fan Aluminum	9'9¾"	1'8"	1'5½"	9'11½"	3'0"	1'5½"
Fan Fiberglass	10'1¾"	1'8"	1'5½"	10'0"	3'0"	1'5½"
Fan Glass	10'1½"	1'8"	1'5½"	9'11¾"	3'0"	1'5½"
72" x 42" Rectangular Fiberglass	9'9"	3'0"	2'7½"	9'10½"	3'0"	1'5½"
72" x 42" Rectangular Glass	9'9"	3'0"	2'7½"	9'10½"	3'0"	1'5½"
72" x 42" Rectangular Steel	10'17/8"	1'8"	1'5½"	10'01/8"	3'0"	1'5½"
72" x 42" Rectangular Wood	9'8"	3'0"	2'7½"	9'9½"	3'0"	1'5½"
72" x 48" Rectangular Fiberglass	9'3"	3'6"	2'7½"	9'10½"	3'0"	1'5½"
72" x 48" Rectangular Glass	9'3"	3'6"	2'7½"	9'10½"	3'0"	1'5½"
72" x 48" Rectangular Steel	10'17/8"	1'8"	1'5½"	10'01/8"	3'0"	1'5½"
72" x 48" Rectangular Wood	9'3"	3'6"	2'7½"	9'10½"	3'0"	1'5½"

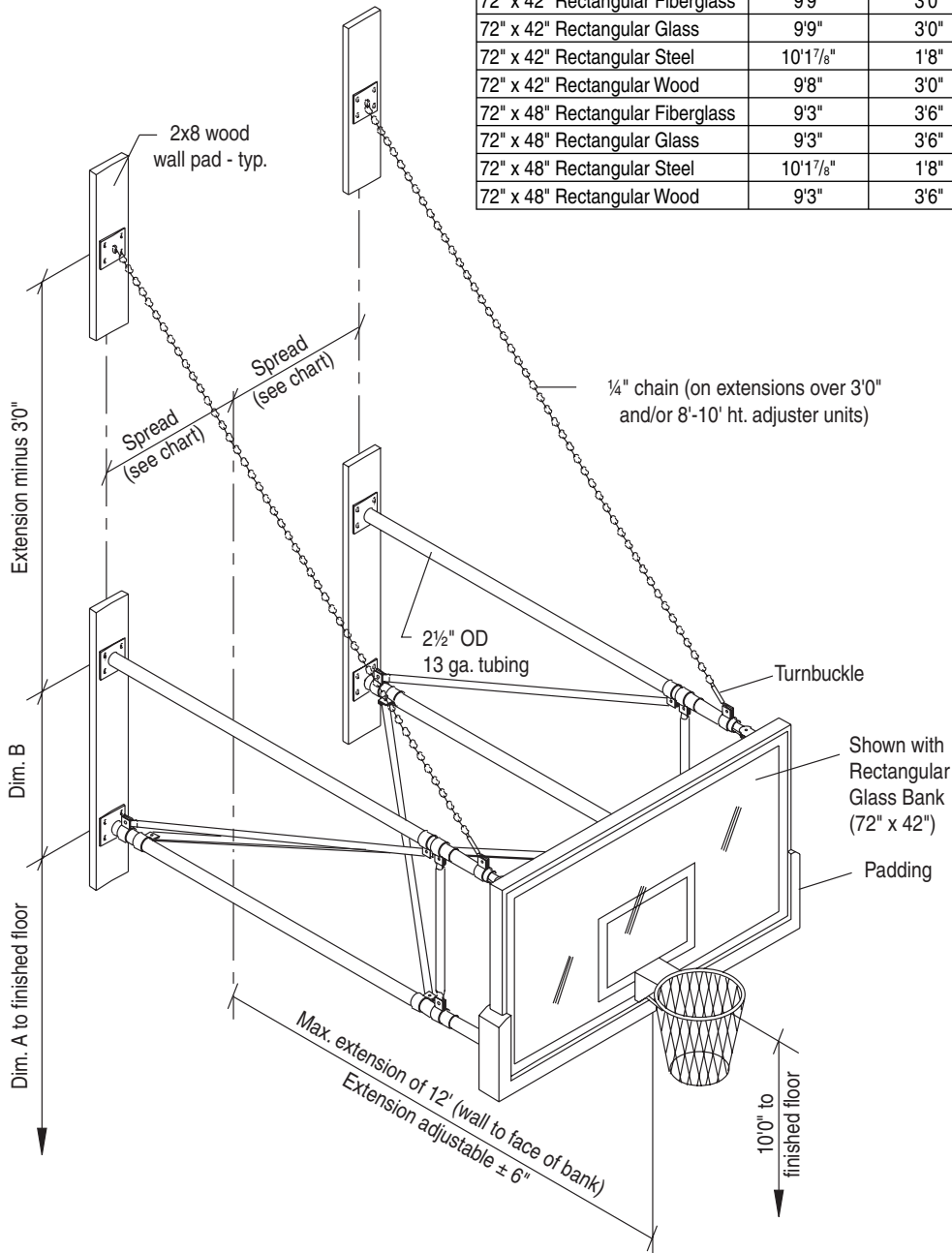

Draper offers a 25-year limited warranty on the EZ-Fold® basketball backstop structure. No other basketball backstop manufacturer offers you this protection. For a copy of the EZ-Fold® backstop warranty in its entirety, contact Draper, Inc.

DRAPER®

411 S. Pearl St., Spiceland, IN 47385 USA ■ 765-987-7999
www.draperinc.com ■ fax 765-987-7142

Copyright © 2010 Draper Inc. Form EZ-SW_Sub10 Printed in U.S.A.

PROJECT: _____
ARCHITECT: _____
CONTRACTOR: _____
SUPPLIER: _____
DATE: _____ REVISED: _____

Specifications—EZ Fold SW

Wall-Mounted, Stationary Backstop

Product Description

Basketball Backstop shall be the EZ FOLD Model SW, stationary backstop by Draper, Inc. of Spiceland, IN.

Extension frame shall be constructed of (4) 2½" (6.35 cm) 13 gauge and 2¼" (5.715 cm) 14 gauge steel tubes terminating in fabricated steel plates. The frame shall be attached to the wall and the bank. On extensions greater than 3'0" (91.44 cm) or units with height adjusters shall be supported in playing position by two ¼" (6.35 mm) welded-link chains w/turnbuckles for leveling. Frame shall be adjustable for a plus or minus 6" (15.24 cm) variation of distance from face of bank to wall.

Frames shall be further braced by ¼" (6.35 mm) x 1½" (3.81 cm) steel cross brace terminating in precision die-formed clamps. Frames shall have a black or white powder coat finish. Other colors available: contact Draper for details.

Backstop shall be provided with 2 x 8 (5.08 cm x 20.32 cm) southern yellow pine wall pads at wall attachment points. All edges shall be chamfered and pads shall be finished with high gloss polyurethane.

**Downloadable 3-part specifications
are available at www.draperinc.com.**

Options

Backstop can be provided with any of several different styles of backboards, goals and padding. Specify types desired. See separate sheets.

Accessories

Height Adjusters (see separate sheets):

- 503093**— For motorized 8'-10' (244 cm-305 cm) height adjustment of rectangular bank.
- 503097**— For motorized 8'-10' (244 cm-305 cm) height adjustment of fan bank.
- 503095**— For motorized 8'-10' (244 cm-305 cm) height adjustment of rectangular bank with wireless remote control.
- 503098**— For motorized 8'-10' (244 cm-305 cm) height adjustment of fan bank with wireless remote control.
- 503096**— For motorized 8'-10' (244 cm-305 cm) height adjustment of rectangular bank with EZ Stick Power Wand.
- 503099**— For motorized 8'-10' (244 cm-305 cm) height adjustment of fan bank with EZ Stick Power Wand.
- 503092**— For manual 8'-10' (244 cm-305 cm) height adjustment of rectangular backboards.
- 503094**— For manual 8'-10' (244 cm-305 cm) height adjustment of fan backboards.

LEED® Submittal Information

Credit	Measure	
MRc4 – Recycled Content	Post Consumer Average 26.90%	Post Industrial 0%
MRc5 – Regional Materials	Raw materials are commodity items from multiple sources so extraction point cannot be determined. Final Manufacturing/Assembly in Spiceland, IN 47385.	