

EZ Fold® 503581

Breakaway Basketball Goal with
Tube-Tie Net Attachment

by DRAPER

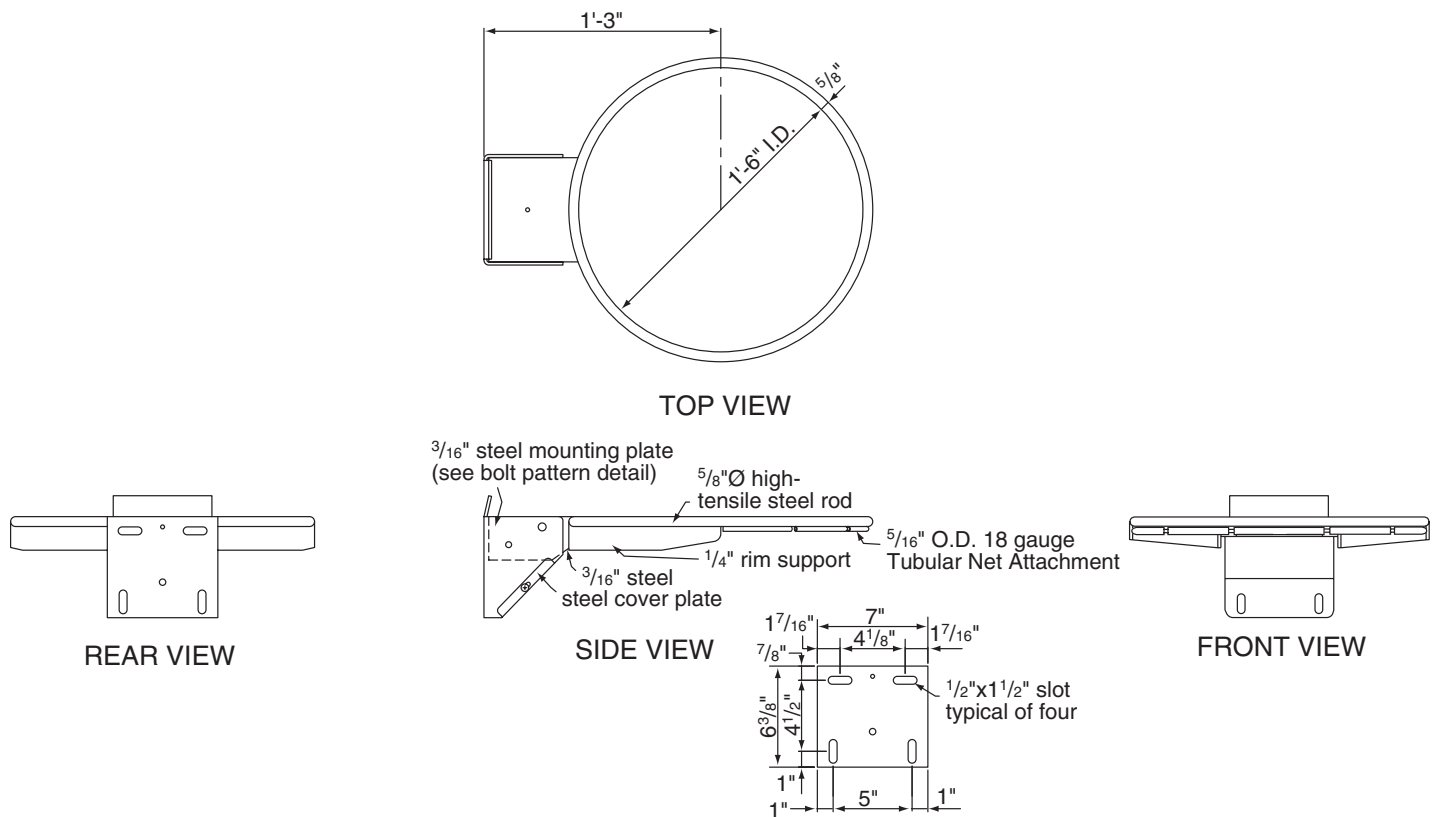

Specifications—EZ Fold 503581

Breakaway Basketball Goal (42" & 48" banks) with Tube-Tie Attachment, Hardware and Anti-Whip Net

Product Description

503581 breakaway goal is designed to withstand shock loads due to a player slam dunking and/or hanging on the rim. The rim shall deflect down when a static load of 230 pounds is applied. The rim will return to the playing position once the load is removed.

The function of the breakaway goal shall meet NCAA specifications which state: "A movable basket ring shall have rebound characteristics identical to those of a non-movable ring." Goal shall be set at factory for proper flex and rebound requirements.

This goal features Draper's easy-adjust system, which allows the end-user to adjust the breakaway point from 160 lbs. to 230 lbs.

Goal features tube-tie net attachment, which consists of a series of small tubes welded below the rim and a 1/8" nylon cord which passes through the tubes, catching the net loops between the tubes. The tube-tie provides superior strength and a smooth attachment system for maximum player safety.

Rim shall be fabricated from a 5/8" diameter steel rod formed into an 18" inside diameter ring. Inside of ring shall be positioned 6" from the face of backboard by a heavy-duty mounting plate with mounting holes centered to match 5" x 5" or 5" x 4" backboard mounting holes. Goal will mount on standard glass, fiberglass and wood banks.

Rim shall be rigidly braced by means of die cut steel braces formed and welded to underside of rim for maximum support.

Goal shall be powder coated in an official durable orange powder coat. Goal shall be furnished with zinc plated mounting hardware.

Goal provided with white nylon Anti-Whip Net. The top half of the anti-whip net is made of durable fibers encased in tough 100% nylon, preventing the net from whipping up on the rim. The lower half is all nylon.

DRAPER®

411 S. Pearl St., Spiceland, IN 47385 USA ■ 765-987-7999
www.draperinc.com ■ fax 866-637-5611

Copyright © 2010 Draper Inc. Form EZ-503581-TubeTieBreakawayGoal_Sub10

Printed in U.S.A.

PROJECT: _____

ARCHITECT: _____

CONTRACTOR: _____

SUPPLIER: _____

DATE: _____ REVISED: _____