

Installation Instructions

Heavy Duty Outdoor Basketball Backstop by Draper

Caution

- ① Immediately unpack all components and cross check against bill of materials.
- ② The extension arm will not balance by itself, serious injury may occur if arm is allowed to fall.
- ③ Allow 48 hours of drying time for concrete before completing installation. It is advisable to wait up to two weeks to allow the anchor footing to fully cure before aggressive play.
- ④ Follow instructions carefully.

Bill of Materials

A (1) Vertical Post	H (2) Backboard Frame Support
B (1) 45 Degree Extension Arm	I (8) $\frac{3}{8}$ " x $1\frac{1}{4}$ " Hex Bolt
C (1) Mounting Plate	J (8) $\frac{3}{8}$ " Flatwasher
D (6) $\frac{5}{8}$ " x 8" Hex Bolt	K (8) $\frac{3}{8}$ " Lockwasher
E (6) $\frac{5}{8}$ " Hex Nut	L (8) $\frac{3}{8}$ " Hex Nut
F (6) $\frac{5}{8}$ " Flatwasher	M (2) $\frac{3}{8}$ " x $2\frac{1}{2}$ " Hex Bolt
G (6) $\frac{5}{8}$ " Lockwasher	

NOTE: Immediately unpack all components and cross check against bill of materials.

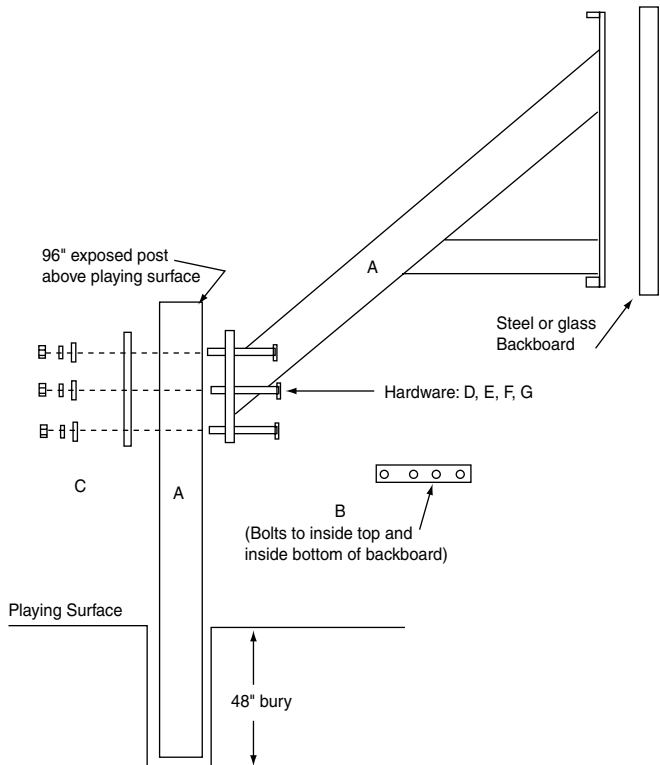

- ① Position the hole taking into consideration that the backboard will be approximately 66" from the front of the vertical post.
- ② Dig a hole 18" in diameter and 48" deep.
- ③ Install post in wet concrete with capped end up. Be sure that at least 96" of post extends above the playing surface to insure adjustment to 10'. Make sure post is installed straight and plumb, brace if necessary while cement cures.
- ④ After allowing 48 hours drying time for the concrete, mount the 45 degree extension arm as shown. Arm can be mounted loosely at ground level and

slid up the pole or mounted at correct height depending on lifting equipment available. Use hardware D, E, F and G.

Caution: The extension arm will not balance by itself, serious injury may occur if arm is allowed to fall. Making sure to keep the rim holes in the backboard in line with the rim holes in the extension arm faceplate, use a $\frac{3}{8}$ " drill bit to drill two attachment holes through the backboard at points N & O shown in Fig. C (if necessary).

- ⑤ Loosely attach both backboard frame supports (part H) to the inside top and bottom of your backboard using the $\frac{3}{8}$ " hex bolts, etc. as shown in figure A. Note: for this step only attach the backboard frame supports using the two outermost holes. Do not bolt the support at the center two holes.

ATTENTION: If your backboard is tempered glass or acrylic check to make sure all four steel grommets are located in the rim holes, if any are missing check in the box. If grommets are missing and cannot be located DO NOT proceed with assembly, call Draper immediately. Additionally, if your backboard is acrylic you will find two black rubber gaskets packaged in with your backboard. Disregard these gaskets, you will not need them.

- ⑥ Lift and slide backboard onto extension arm aligning the attachment holes at the top and bottom of extension arm with the holes in the backboard frame.
- ⑦ Bolt backboard to extension arm at all points along the top and bottom using the remaining $\frac{3}{8}$ " x $1\frac{1}{4}$ " hex bolts, etc. Make sure rim hole pattern in the extension arm faceplate lines up with the rim hole pattern in the backboard, then tighten all $\frac{3}{8}$ " hardware.
- ⑧ Attach rim using the hardware provided in the rim box. Level rim with backboard, tighten rim hardware and attach net. Check over entire unit and make sure all hardware has been tightened.

Tip: If you are setting the unit at 10', the bottom of the 45 degree extension arm will be bolted 75½" up the vertical post.

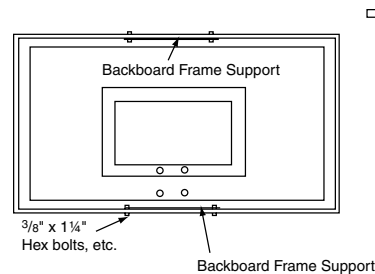

Figure A

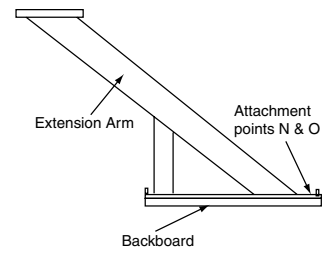

Figure B

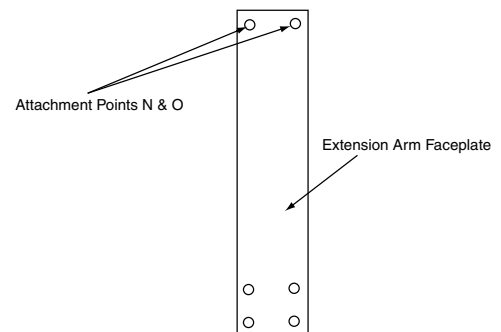

Figure C

DRAPER