

Installation Instructions

s_enn[®] Exterior Stainless Steel Shading System by Draper

⚠ Caution

- ① Never push the bottom rail of the system up by hand. This can cause irreparable damage.
- ② Access equipment must not be leant against the blind nor secured to it.
- ③ When working at height there is a risk of falling. Appropriate access equipment, harnesses, etc., must be used.
- ④ The blind may only be connected to the power supply if the electric motor's specification corresponds to the power source rating (see operating instructions). The instructions enclosed with the electrical components supplied with the product must be followed.
- ⑤ The systems should only be used for their intended purpose, i.e. as shading systems. Any alterations or modifications to the system should only be carried out with Draper's written consent. Placing additional strain on the system, e.g. by using rope restraints or suspending objects from the system, is not allowed, as it could cause the system to fail.
- ⑥ When operating the system, ensure that there are no people or obstacles blocking its path or touching any part of the system. When the system is being operated, keep hands away from the hem bar and the side guide tracks as there is a risk of fingers being trapped and injured.
- ⑦ The system is shipped without fasteners. The appropriate fasteners need to be selected by the installer by reference to the structure that the system is being attached to. Where the system is attached directly to the curtain wall, the method of installation needs to be discussed and agreed with the curtain wall contractor.
- ⑧ The system is designed for exterior use and can withstand significant wind loads. In order for this to be the case, however –
 - All the brackets supplied with the system and shown in the drawings must be used and attached to the building structure with the appropriate number of fasteners,
 - The fasteners should be selected based on a maximum applied load of 110N/m² multiplied by the area of the system, and
 - The system must be connected to the support structure in the proper way for its intended use.
- ⑨ The system should not be operated by children or by anybody who is not able to understand the potential problems if it is not used correctly. Remote controls are to be kept out of their reach.
- ⑩ Any moisture on the system, when either deployed or retracted, can cause the blind to 'freeze fast' when temperatures are close to freezing (6°C / 43°F or lower). If a blind is operated in this condition, significant damage can occur.
- ⑪ **Please read the following installation guidelines thoroughly and follow them carefully. Failure to do so may cause product to fall or otherwise fail, and invalidates warranty.**

Installation Preparation

Lifting with Ropes

If the system needs to be hoisted to the location where it will be installed, then it must be:

- taken out of the packaging;
- fastened to the ropes that will be used to hoist it in such a way that they cannot slip off; and
- pulled up smoothly with the system vertical.

This also applies when a system is taken down.

Installation Grounds

Before installation is started, the supporting structure must be checked to ensure that it can accommodate the applied loads.

When installing directly to curtain wall mullions, it is important to ensure that the fixing bolts are screwed directly into the 'nosing' of the mullion and that there is no contact with the glazing or the glazing bead as this could cause the glass to crack. Installation of the system to the curtain wall should only be undertaken after discussion and agreement of the installation method with the curtain wall contractor.

Operating without Automatic Controls

Automatic controls, if used with the system, should be disabled to ensure that the system cannot operate when it is being worked on. To do this, power to the system must be shut off either by turning off the electrical circuit to which it is connected or by disconnecting the plug connection at the motor.

Testing

The system must be tested once it has been installed to ensure that it is operating correctly. The system must be operated from a test lead so that the person doing this can see it in operation and can immediately turn off power if there are any problems. When the system has been fully operated, ie deployed and retracted, it should be visually inspected to ensure that nothing has come loose or has moved.

The motor limits are set in the factory. If these need to be adjusted for any reason, follow the instructions on page 11.

If the system is to be connected directly to a switch, follow the wiring layout on page 11. If other controls are going to be used to operate the system, please ensure that it is wired in accordance with the supplied instructions.

Safe Operation of the System

With an operable system, there is a potential risk of injury if someone is near it when it is being operated. Fingers can get caught in the side guides or someone could be hit by the bottom rail as the system is being deployed.

If the system is installed in a public location and it deploys to less than 8' above ground level, it should not be operated automatically. Switches should be located in a place where the person operating the system has full view of it and can stop the system from being deployed or retracted if required.

Handover

Prior to handover of the system to the owner, those responsible for the operation of it must be given appropriate training and be supplied with an operations and maintenance manual.

They must be advised about the risks of damage to the system through wind and ice and the automatic controls must be set with appropriate wind and temperature settings.

DRAPER[®]

411 S. Pearl St., Spiceland, IN 47385 USA ■ 765-987-7999

www.draperinc.com ■ fax 765-987-7142

Copyright © 2014 Draper Inc.

Form s_enn_Inst14

Printed in U.S.A.

Continued on next page

If you encounter any difficulties installing or servicing your s_enn system, call your dealer or Draper, Inc. in Spiceland, Indiana, 765-987-7999, or fax 765-987-7142.

Type SN 70.1 s_enn® with Guide Rod

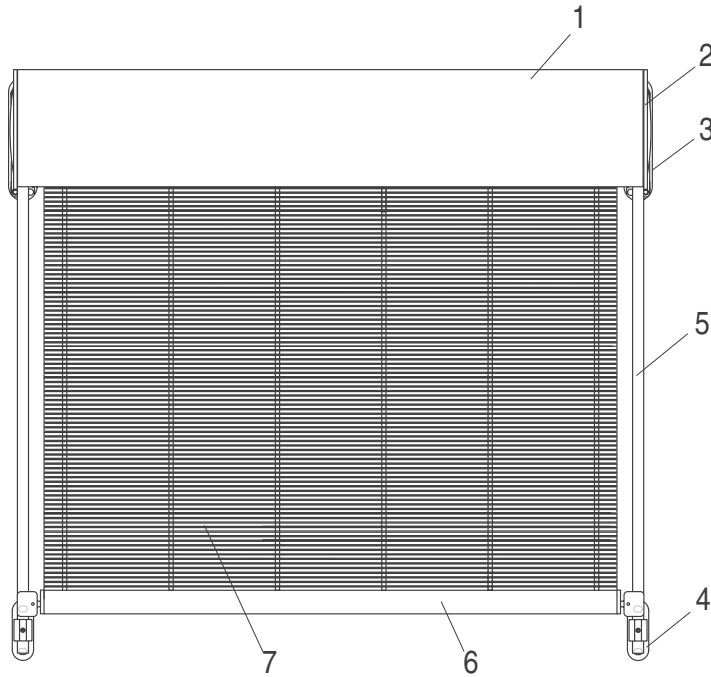

- ① Headbox
- ② Endcap
- ③ Headbox Bracket
- ④ Side Guide Bracket
- ⑤ Guide Rod
- ⑥ Bottom Rail
- ⑦ s_enn® Stainless Steel Curtain

Type SN 71.1 s_enn® with Guide Rail

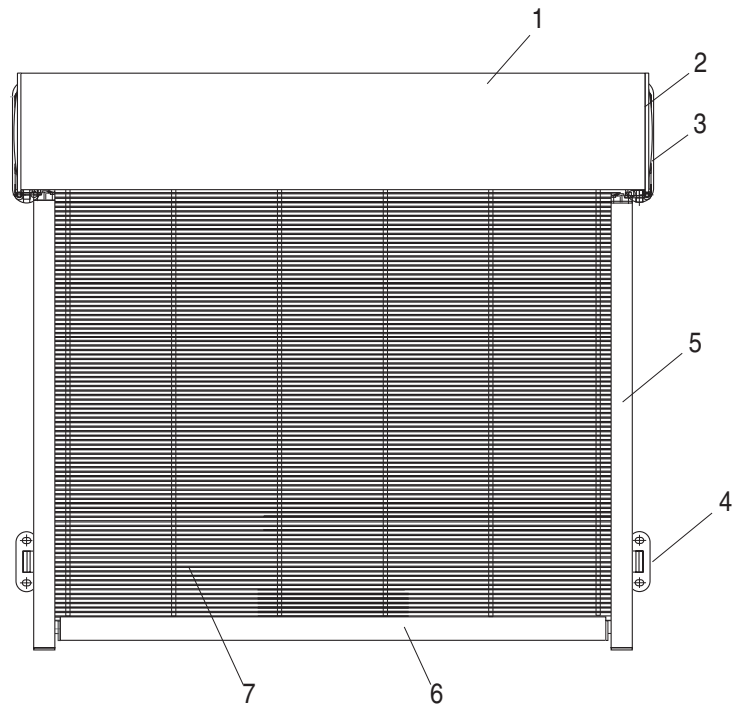

- ① Headbox
- ② Endcap
- ③ Headbox Bracket
- ④ Side Guide Bracket
- ⑤ Guide Rail
- ⑥ Bottom Rail
- ⑦ s_enn® Stainless Steel Curtain

Note:

Check delivery immediately for any damage in transit. Compare materials received with the delivery note to ensure that nothing is missing.

Checking the fixing grounds:

Prior to installation, the installer must check the structure to which the system is being attached to ensure that it is adequate.

If the system is being attached to a curtain wall, no work should be undertaken prior to agreement of the installation details and the method of attachment of the system to the curtain wall with the curtain wall contractor. Ideally, the curtain wall contractor will pre-drill the mullions or provide studs to which the system brackets will be connected.

Operational note:

The s_enn system is designed to provide shading and solar control and not for general weather protection. The system should always have an automatic control with sensors that measure wind speed, temperature and humidity. The system should automatically retract if the wind speed is above the maximum allowable limited and should not be able to be deployed if there is a risk of ice.

Anyone undertaking the installation of the system must have undertaken training with Draper before doing so.

Required tools:

- #10 and #13 metric wrenches
- #3, 4, and 5 metric Allen wrenches (Hexagon key)
- Carpenter's level

Continued on next page

1.1 System Type SN 70.1

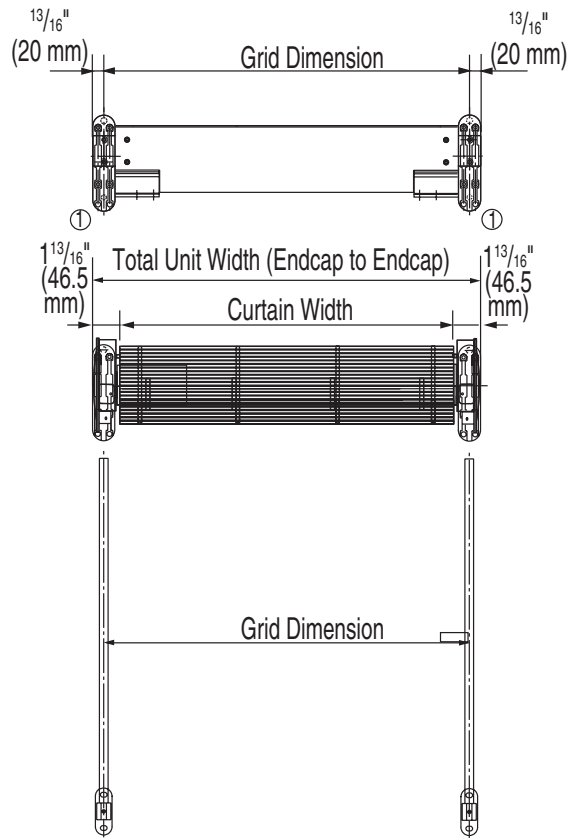

2.1 System Type SN 71.1

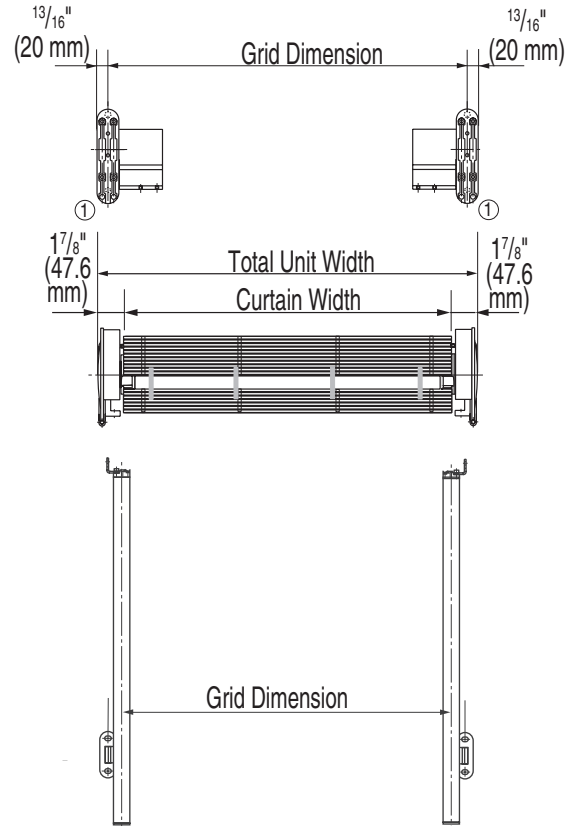

Continued on next page

3.1 Installation Standard Screws—SN 70.1

3.2 Using Countersunk Screws—SN70.1

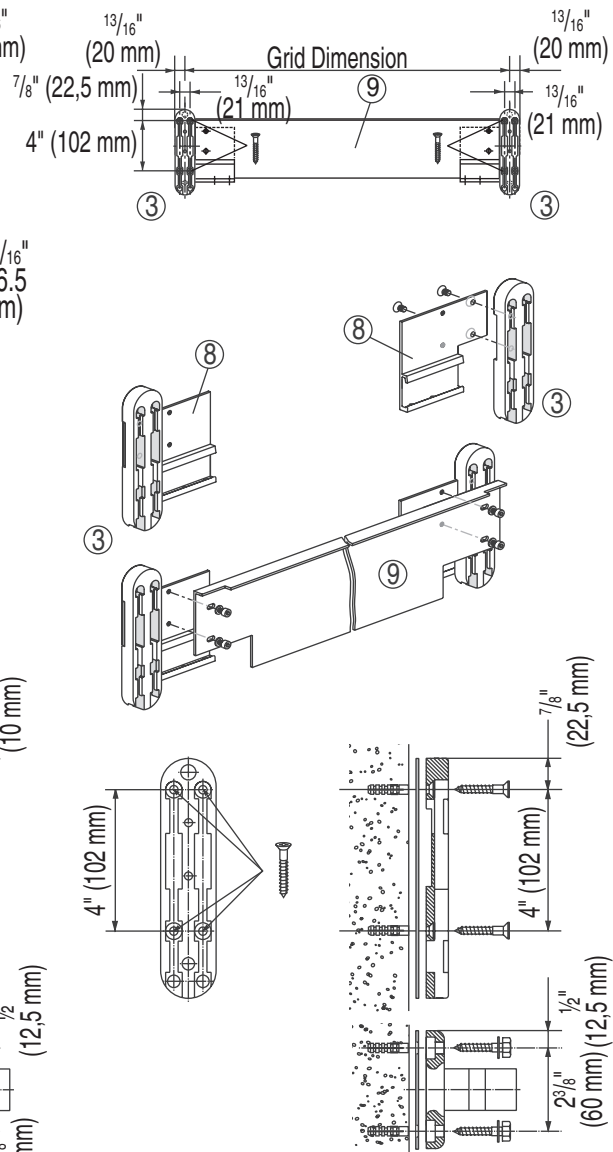
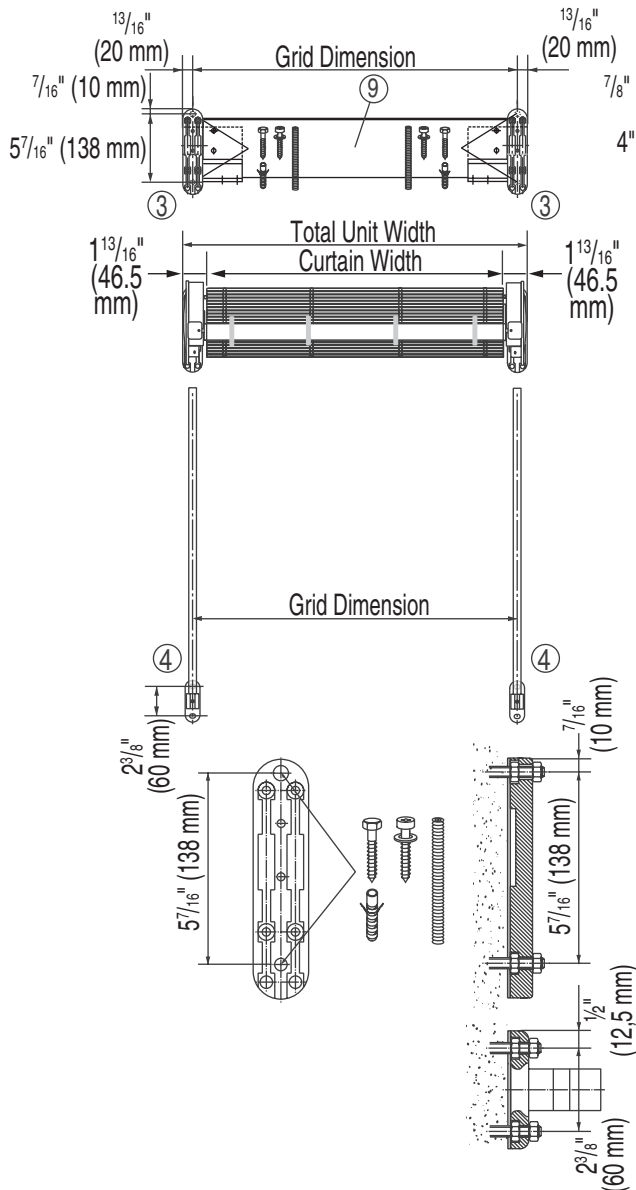

- ① The brackets can be attached to the building structure using a variety of fasteners including hex head bolts, threaded studs and bolts and countersunk screws. Depending upon the fasteners, different holes in the brackets are used for the connections.
As seen in 3.1, with hex head bolts and studs / nuts, the connections are made through the two clearance holes on the center line of the bracket. With countersunk screws (3.2) the connections are made through four recessed, countersunk holes.
- ② Using a template, as appropriate, place a bracket in the required location and mark the hole positions. Repeat for other bracket locations (other head box bracket and side guide brackets). Drill holes and install brackets.

- ③ With a single system, the endcaps are inserted in the outer grooves of the headbox brackets. With adjacent systems, it is possible to use the same headbox bracket for both systems to reduce the gap between them.
- ④ If the system incorporates a rear cover plate to the head box (generally when the head box is visible from the interior of the building), back plates (8) should be attached to the head box brackets before they are installed. The rear cover plate (9) can then be installed.

Continued on next page

3.3 Installation Using Standard Screws—SN71.1

3.4 Using Countersunk Screws—SN71.1

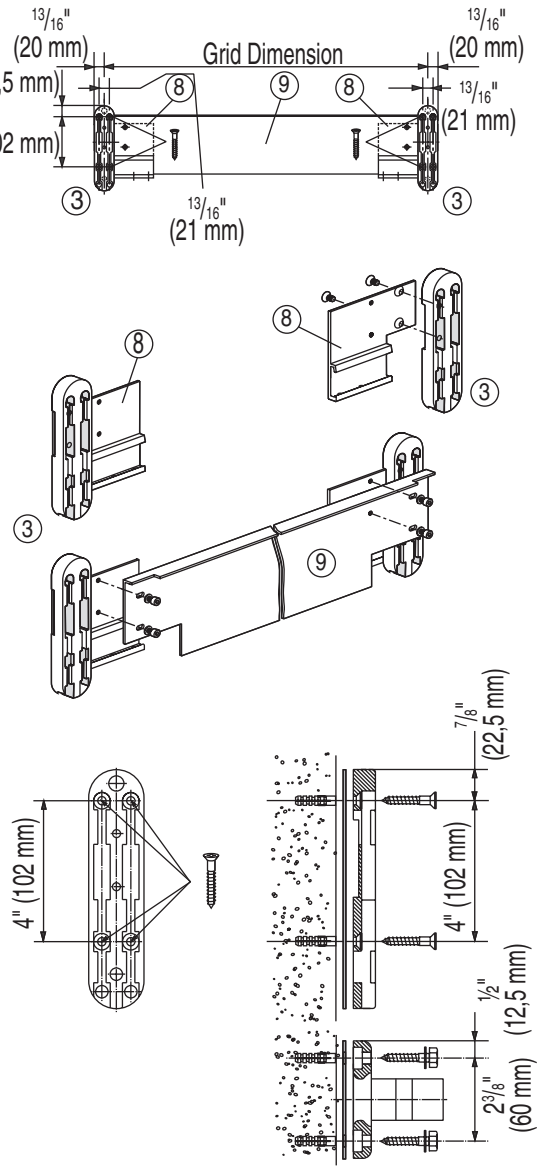
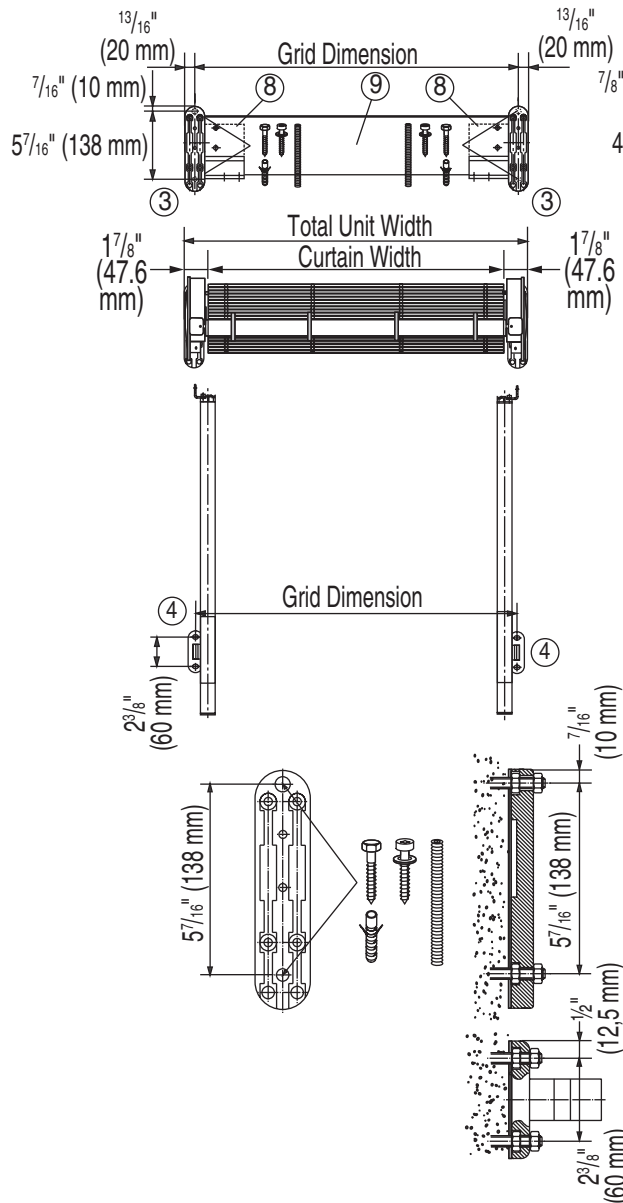

- ① The brackets can be attached to the building structure using a variety of fasteners including hex head bolts, threaded studs and bolts and countersunk screws. Depending upon the fasteners, different holes in the brackets are used for the connections. As seen in 3.1, with hex head bolts and studs / nuts, the connections are made through the two clearance holes on the center line of the bracket. With countersunk screws (3.2) the connections are made through four recessed, countersunk holes.
- ② Using a template, as appropriate, place a bracket in the required location and mark the hole positions. Repeat for other bracket locations (other Headbox bracket and side guide brackets). Drill holes and install brackets. **Please Note: If the drop of the blind is 78 3/4" (2m) or more, an additional set of side guide brackets will be required. These (and their required**

- location) will be shown in the supplied drawing. The maximum system height must not exceed 110 1/4" (2.8m).**
- ③ With a single system, the endcaps are inserted in the outer grooves of the headbox brackets. With adjacent systems, it is possible to use the same headbox bracket for both systems to reduce the gap between them.
- ④ If the system incorporates a supporting roller assembly and / or a rear cover plate to the Headbox (generally where the head box is visible from the interior of the building) back plates (8) should be attached to the head box brackets before they are installed. The rear cover plate (9) can then be installed.

Continued on next page

4 Fixing the roller tube assembly with stainless steel curtain into the wall bracket

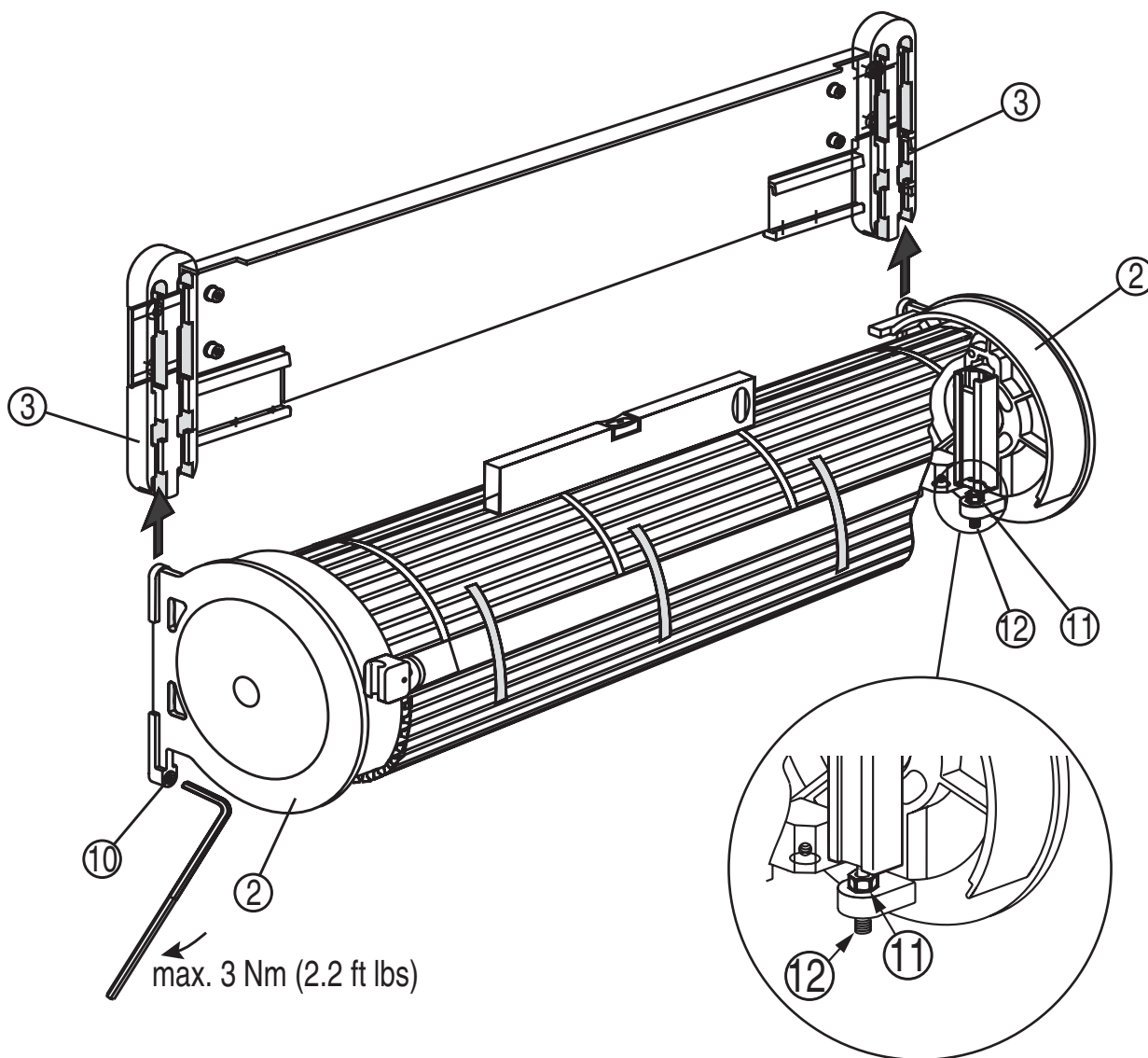

Please Note: Prior to starting the installation, the Headbox must be dismantled.

- ① Slide the Endcaps (2) up into the outer grooves of the Headbox brackets (3). Push the Endcaps up as far as they will go.
- ② Tighten the two setscrews (10) with 3 Nm of torque (#4 Allen key).

- ③ Use a carpenter's level to ensure the unit is level.
- ④ If required, adjust the horizontal position using the vertical adjustment setscrew (12) (this takes a #4 metric Allen wrench). To lock in place, use a #13 metric wrench to tighten the locking nut (11).

Continued on next page

5 Fixing the supporting roller assembly (SN 71.1 system only)

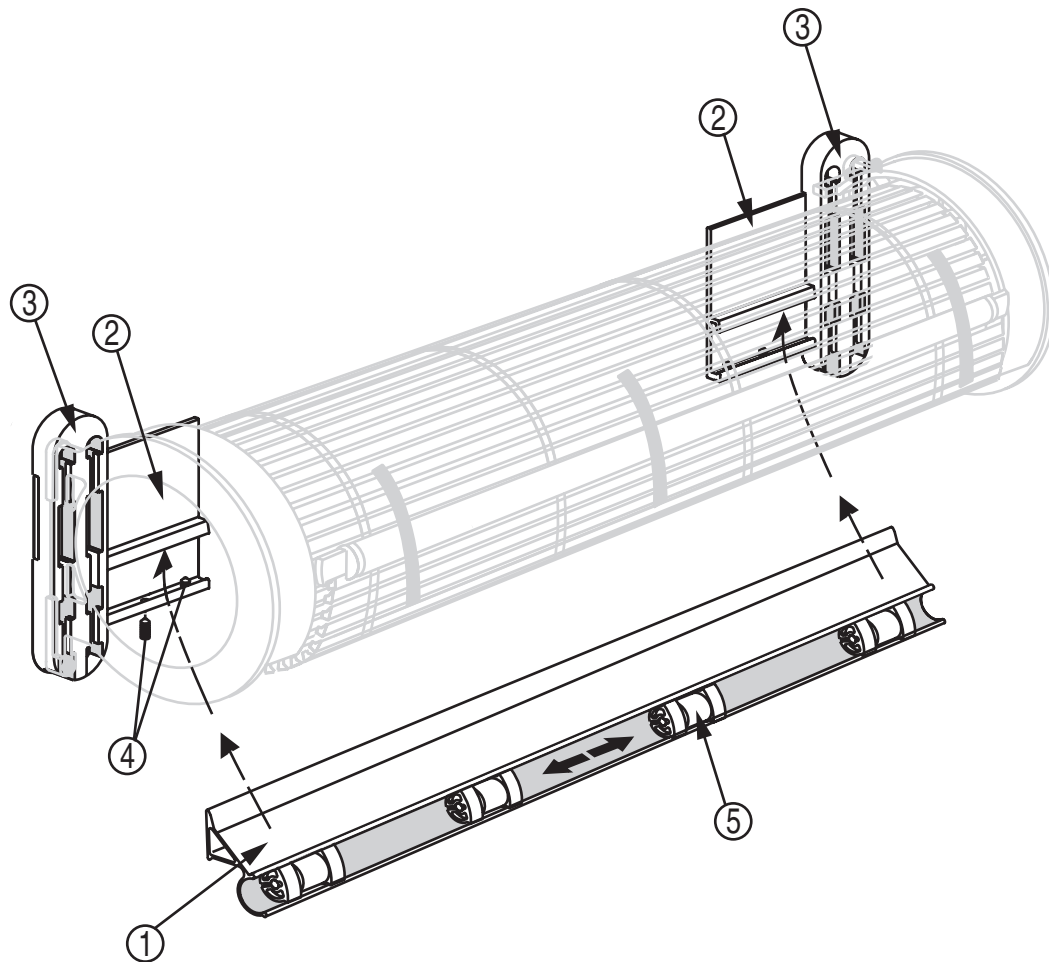

- ① Ensure that back plates (2) have been attached to the head box brackets (see page 5 of 11).
- ② Tilt the roller assembly (1) slightly up from horizontal and present the top edge of the back part of the assembly into the upper slot of the back plates (2).
- ③ Rotate the assembly to vertical and lower it so that the bottom edge of the back part of the assembly seats into the lower groove.

Please Note: The Supporting Roller Assembly must be centered precisely between the Headbox Brackets (3).

- ④ Ensure that the supporting rollers (5) align with the welded stainless steel tapes of the s_enh curtain. If they don't, adjust the position of the supporting roller assembly as required. Once this is the case, secure the supporting roller assembly by tightening the two set screws (4). Note: The purpose of the supporting roller assembly is to ensure that the s_enh curtain properly tracks into the guide rails.

Continued on next page

6.1 Fixing the Guide Rods—type SN 70.1

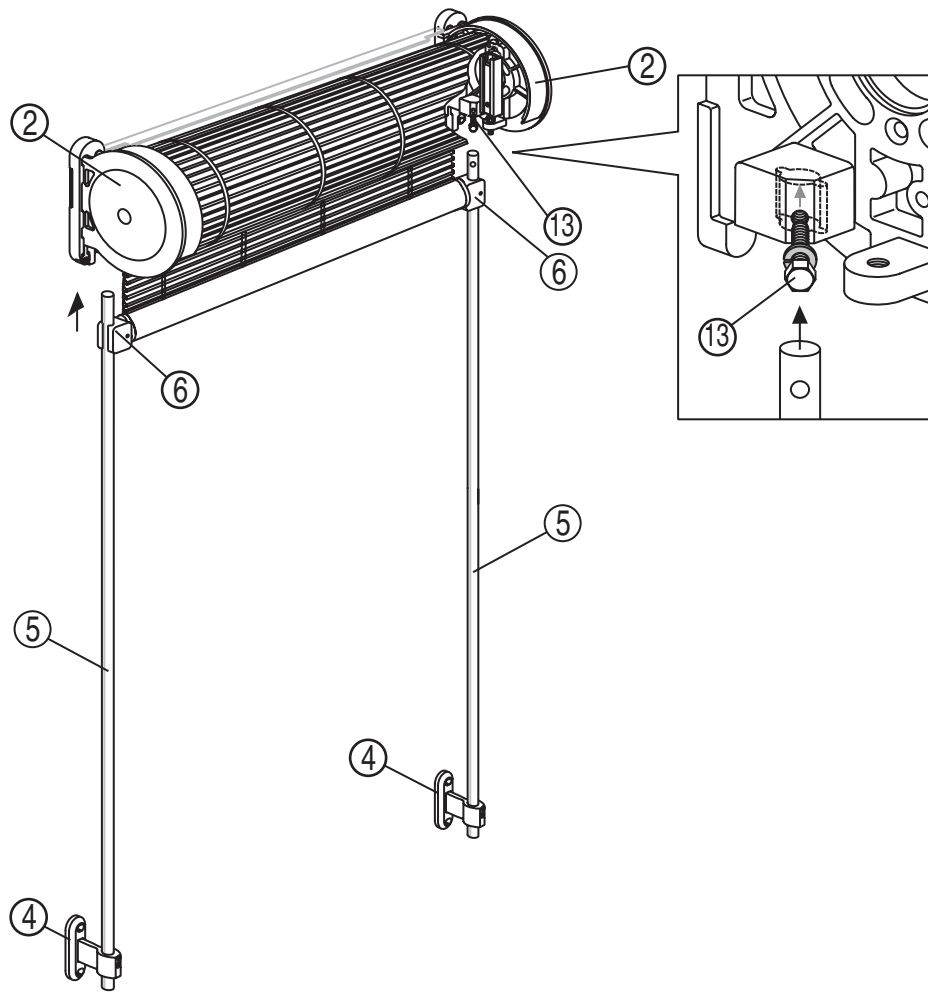

- ① Remove security tape from the rolled up curtain
- ② Connect a test lead to the motor whip and run the curtain down 3¹⁵/₁₅" (10cm).
- ③ Ensure that the hole in the guide rod is at the top. Slide the guide rod down so that it goes into the side guide bracket at the bottom of the system. Raise the guide rod and slide it up through the fitting at the end of the bottom rail. Continue raising and locate it into the hole in the end cap as shown in the detail above. Lock the guide rod into place with the fastener (13), using a #10 metric wrench.

- ④ Tighten the screw to lock the guide rod into the side guide bracket at the bottom of the system.
Please Note: The distance between the Guide Rods must be the same at top and bottom.
- ⑤ Repeat steps 3 and 4 for the second guide rod.
- ⑥ Use the test lead to operate the system. Make certain that the curtain remains parallel and the bottom rail is horizontal as it runs up and down. **If there are any issues immediately stop running the system and make adjustments as required. If not, the system could be damaged.**

Continued on next page

6.2 Fixing the Guide Rails—type SN 71.1

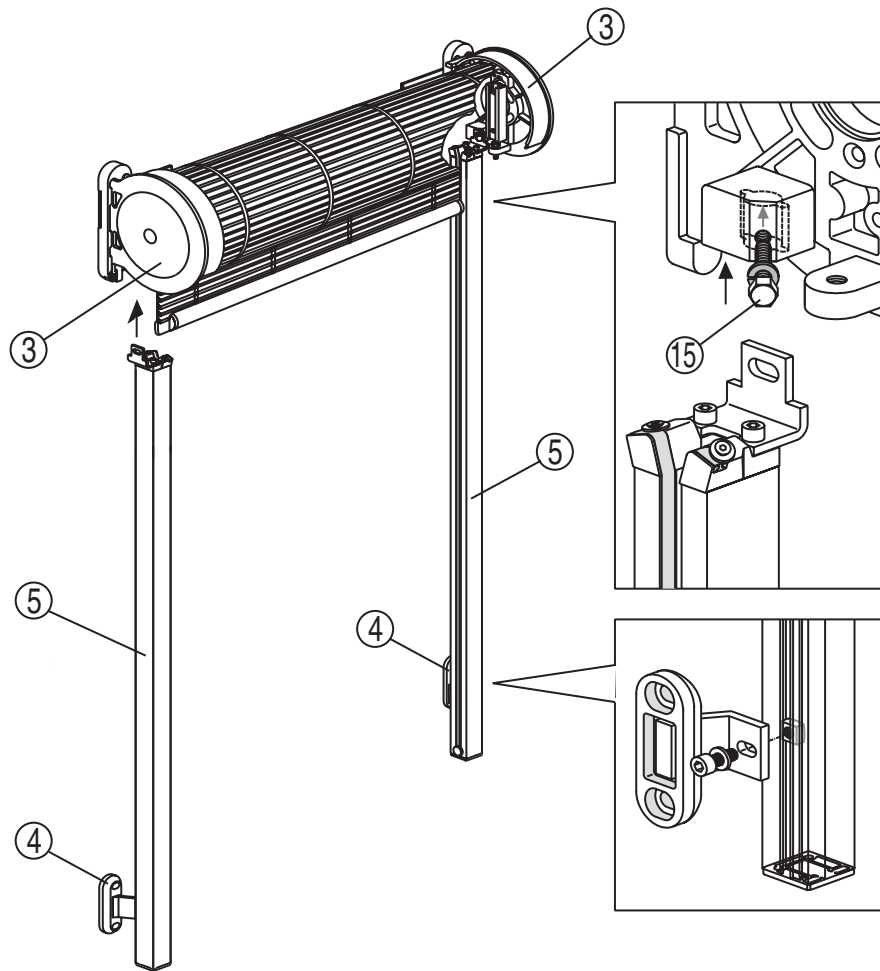

- ① Remove Security Tape from the rolled-up Curtain.
- ② Connect a test lead to the Motor Whip and run the Curtain down 3¹⁵/₁₆" (10 cm).
- ③ Take the first side guide and present it from below so that the bottom rail of the system and the s_en curtain slides into the groove of the side guide. Raise the guide further so that the angle bracket on the top of it slides into the hole in the end cap as shown in the detail above. Use the fastener (15) to hold the side guide into position.
- ④ Using the supplied bolts, connect the side guides to the side guide brackets. As can be seen in the detail above, either one or two nuts (depending on the number of side guide brackets used) are inserted into the side guides to allow the connections to be made.
- ⑤ Repeat steps 3 and 4 for the second side guide.
- ⑥ Ensure that the side guides are parallel to each other and that the distance between the rails is the same at the top and the bottom. The fixing angles for the side guides are slotted to allow small adjustments to be made.
- ⑦ When the side guides are correctly set out, tighten all the fasteners.
- ⑧ Use the test lead to operate the system. Make certain that the curtain remains parallel and the bottom rail is horizontal as it runs up and down. **If there are any issues immediately stop running the system and make adjustments as required. If you don't stop the system and make adjustments, the system could be damaged.**

Continued on next page

7 Fixing the Headbox

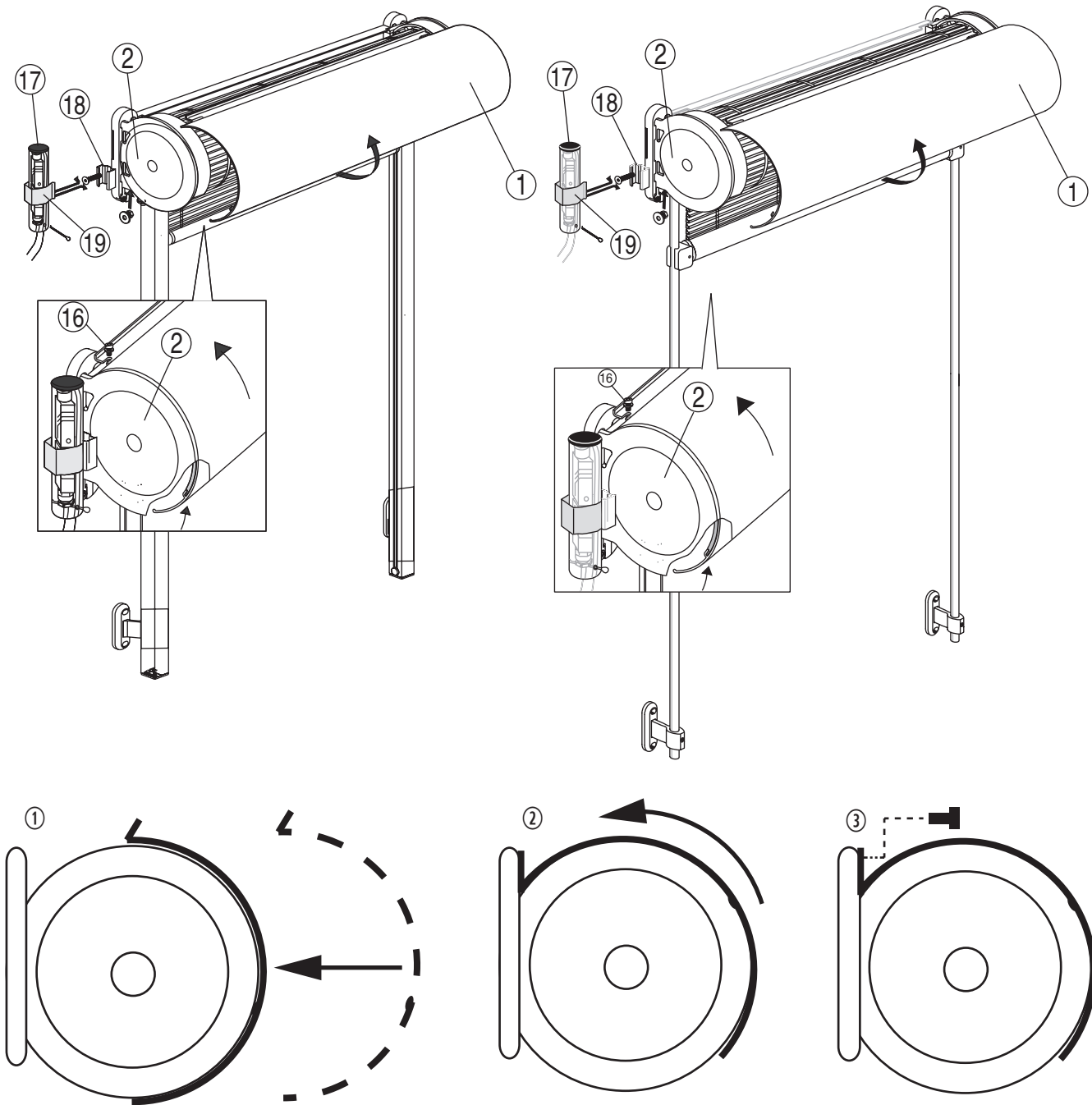

- ① Place the HeadBox Cover (1) on the two Endcaps (2).
- ② Rotate the HeadBox Cover up. There is a ridge in the headbox extrusion which will engage with a lip on the end caps to ensure that it is correctly located.
- ③ Use two screws and washers (16) (provided) to fix the HeadBox Cover in place. These screws require a number 5 (5 mm) Allen wrench.

- ④ Use the test lead to operate the system. **Make certain that the curtain remains parallel and the bottom rail is horizontal as it runs up and down. If there are any issues immediately stop running the system and make adjustments as required. If not, the system could be damaged.**
- ⑤ Fit Protective Sleeve (17) for Hirschmann connector as follows:
 - Use an allen screw, nut and washer to fit the 'C' section to the endcap of the system.
 - Use the retaining plate (19) to clip the protective sleeve (17) into the "C" section.
 - Slide the Hirschmann connector into the tube and hold in place with a split pin (cotter pin).

Continued on next page

Wiring

Standard and Quiet Single Shade Wiring Diagram

Do not wire motorized units in parallel without written consent from Draper.

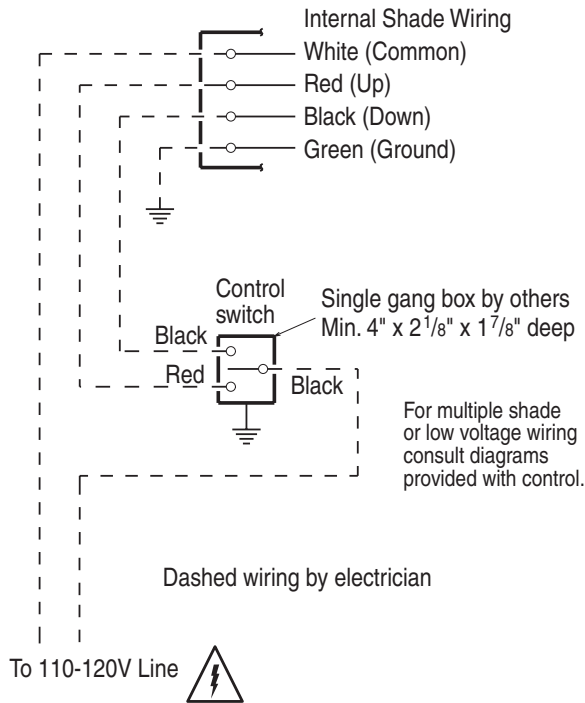

**Radio Technology
110-120V Motors**

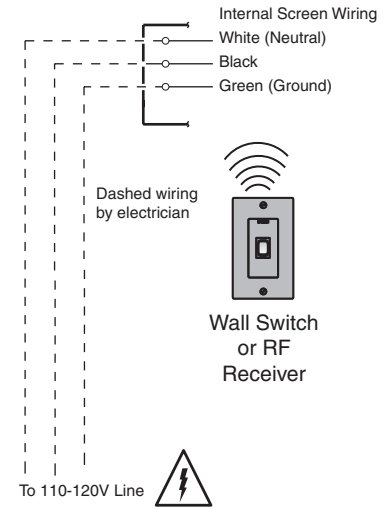

NOTE: Test shade operation. If shade direction does not correspond with the switch orientation, **turn power back off then** switch the red and black wires from the motor to the switch.

Limit Switch Adjustments

Please Note: With the s-enn system, it should be operated from a test lead and not from a wall switch when the motor limits are being set. You need to be right by the system when it is operated so that power can be shut off immediately if something goes wrong. If not, the system could be damaged. Two positions have to be set: The Up (retracted) and Down (deployed) positions. To set them, the required steps are as follows:

- ① Ensure that the test lead switch is in the off position.
- ② Remove the protective cap from the head of the motor to reveal the two limit switches.
- ③ Depress both of the limit switch push buttons which will lock in the down position.
- ④ Use the test lead to move to the required UP position and stop the system.
- ⑤ Identify the UP limit switch button and depress it to release.
- ⑥ Use the test lead to move to the fully extended (DOWN) position and stop the system.
- ⑦ Release the DOWN limit switch button by depressing it.
- ⑧ Operate the system to ensure that the limits have been correctly set.
- ⑨ Refit the protective cap.

Use in Windy Conditions

The s_enn system has been tested in a wind tunnel in wind speeds up to 126 kph / 79 mph. Based on this testing it has been warranted to operate in wind speeds of up to 90 kph / 56 mph. The maximum wind speed can, however, be affected by specific site conditions and the location of the system in relation to the glazing. Depending upon these items, the maximum warranted wind speed might be less than 90 kph / 56 mph and will be specifically advised for each project.

Use in the Rain

The system should generally be retracted whenever it rains. If the blind is retracted when wet or damp, it should be extended again immediately after the rain to dry off.

Use in Snow and Ice

The sunshade system must not be deployed when snow is falling or if there is a risk of frost. There is a danger that in such circumstances the system / stainless steel curtain could become damaged.

⚠ Caution: If any condensation has formed on the stainless steel curtain, either when deployed or retracted, this can cause the blind to 'freeze fast' at temperatures around freezing point (below 6° C/43° F). If a blind that is 'frozen fast' is operated, either by switch or through an automatic control system, there is a risk of damage. It is therefore imperative that automatic controls are turned off throughout the winter and whenever there is a risk of frost (i.e. at below 6° C/43° F).