

# FOUNDATION™

## Installation Manual

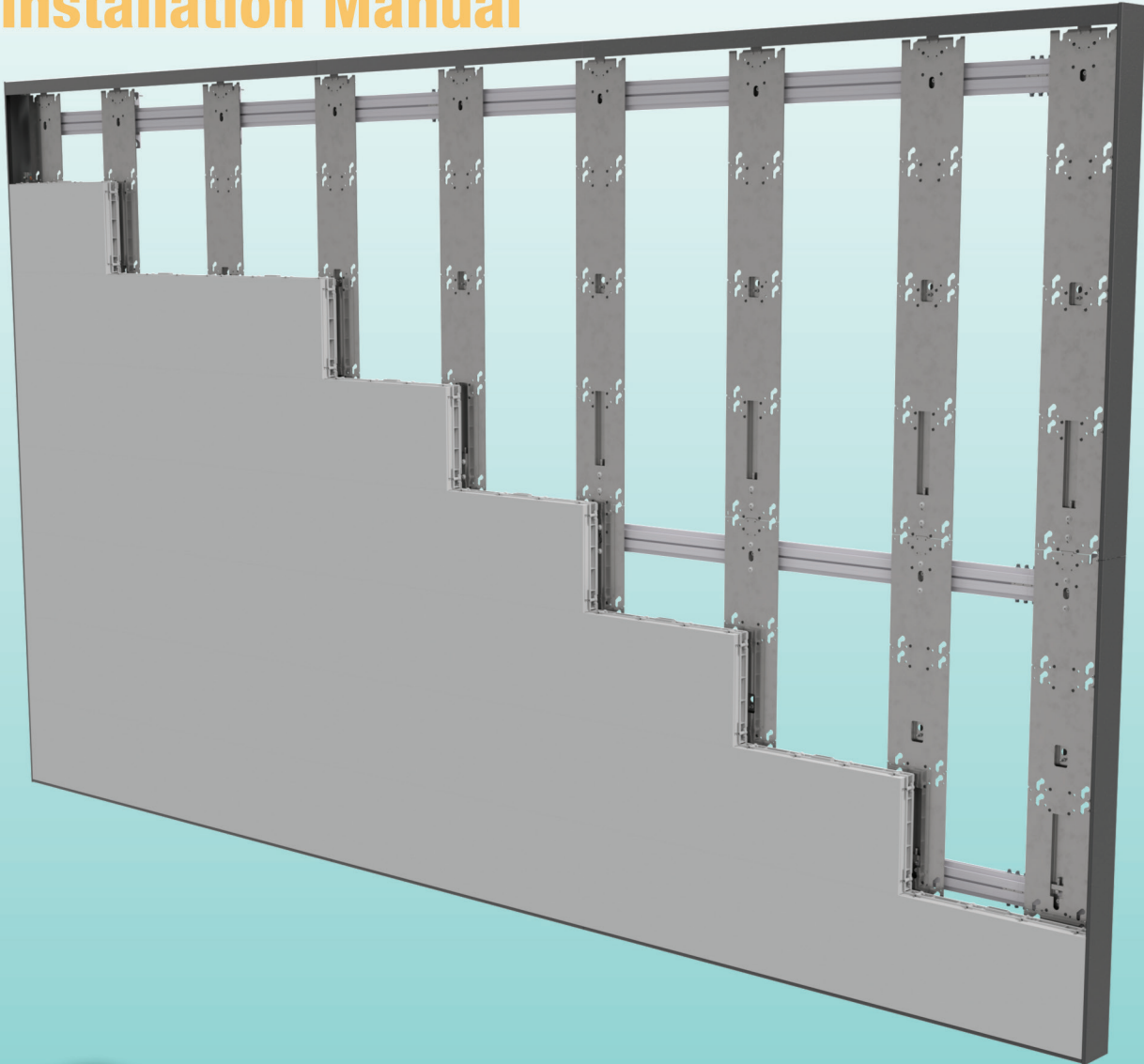

for  
**BARCO**  
XT Series

**LEFT to RIGHT**

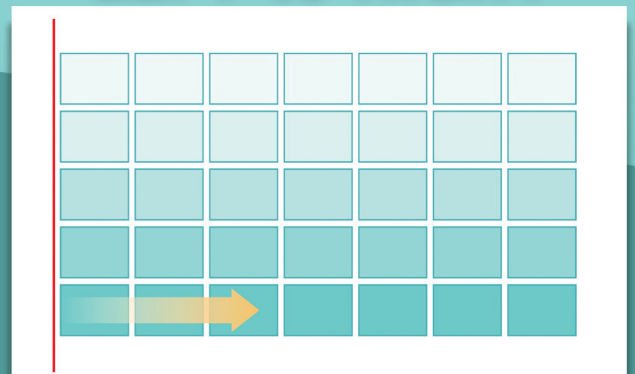

## Important Safety Information



**Improper installation and use of Foundation for LED Panels can result in serious injury or death. Primarily, injuries can occur when the Foundation for LED Panels falls due to imprecise installation, mishandling of the Foundation for LED Panels during installation or installation on an insufficient wall or ceiling structure. Please use extreme care.**

1. Please read the following installation guidelines thoroughly and follow them carefully. Failure to do so may cause product to fall or otherwise fail, and could result in serious injury.
2. Installation and calibration of the Foundation for LED Panels should only be performed by an authorized, qualified, and experienced professional. In particular, electrical work and wiring [indicated in diagram by dashed lines] must be completed only by a qualified professional electrician who has read this manual completely and is familiar with the construction and operation of this equipment and the hazards involved.
3. Turn off power and any nearby equipment or cables carrying electricity before connecting switches, wires, controls, or electrical components.
4. Do not affix the unit to wall or ceilings that have inadequate strength to permanently hold the unit during use. It is the owner's and installer's responsibility to confirm the wall to which the unit attaches is sufficient to permanently hold the weight and stress loads of the unit at all times. Draper, Inc., is not responsible for improper installation, application, testing or workmanship related to the product at place of installation.
5. It is the installer's responsibility to make sure appropriate fasteners are used for mounting.
6. All brackets and other hardware must be installed level. Foundation for LED Panels must be level and square.
7. Never leave the area while operating the Foundation for LED Panels during installation, maintenance, or normal operation, unless it is secure and safe.
8. Before testing or operation, carefully inspect the entire area and areas underneath to be sure no persons or objects are in the area.
9. During testing or operation, carefully watch the surrounding area for any potential safety concerns including nearby persons or objects.
10. After installation, the entire system should be carefully tested to ensure safe and normal operation. Extreme care should be taken during testing to remain clear of moving parts to avoid possible injury.
11. Operation of Foundation for LED Panels should be performed only by authorized and qualified personnel, who have been trained in the safe and effective operation of the Foundation for LED Panels & understand its safety features.
12. The safety features of the Foundation for LED Panels should never be disabled, bypassed or overridden. The system should not be operated until all safety features are properly and completely installed, calibrated and tested.
13. Foundation for LED Panels may need to comply with local, state or district rules and regulations, in particular when installed in schools. All applicable rules and regulations should be reviewed before installation and use.
14. Failure to precisely follow installation guidelines invalidates all warranties.
15. Custom products/installations may not be reflected in this manual. Call Draper, Inc., if you have questions about the installation of custom products or any questions about your installation.

## Before Beginning Installation

1. Look for any job site conditions that could interfere with installation or operation of the system.
2. Read carefully and be sure to understand all installation instructions and all related operations manuals. These instructions are intended to as a guide for the installer and owner. They should be followed closely and combined with the expertise of experienced qualified installers. Draper, Inc., is not responsible for improper installation, application, testing or workmanship related to the product at place of installation. Please retain all instructions for future use.
3. Open cartons lengthwise.
4. Locate and lay out all pieces.
5. Inspect all boxes to make sure you have received the proper Foundation for LED Panels and parts.
6. If you have any difficulties with installing, servicing or operating your Foundation for LED Panels, call your dealer or Draper, Inc., 765 987-7999.

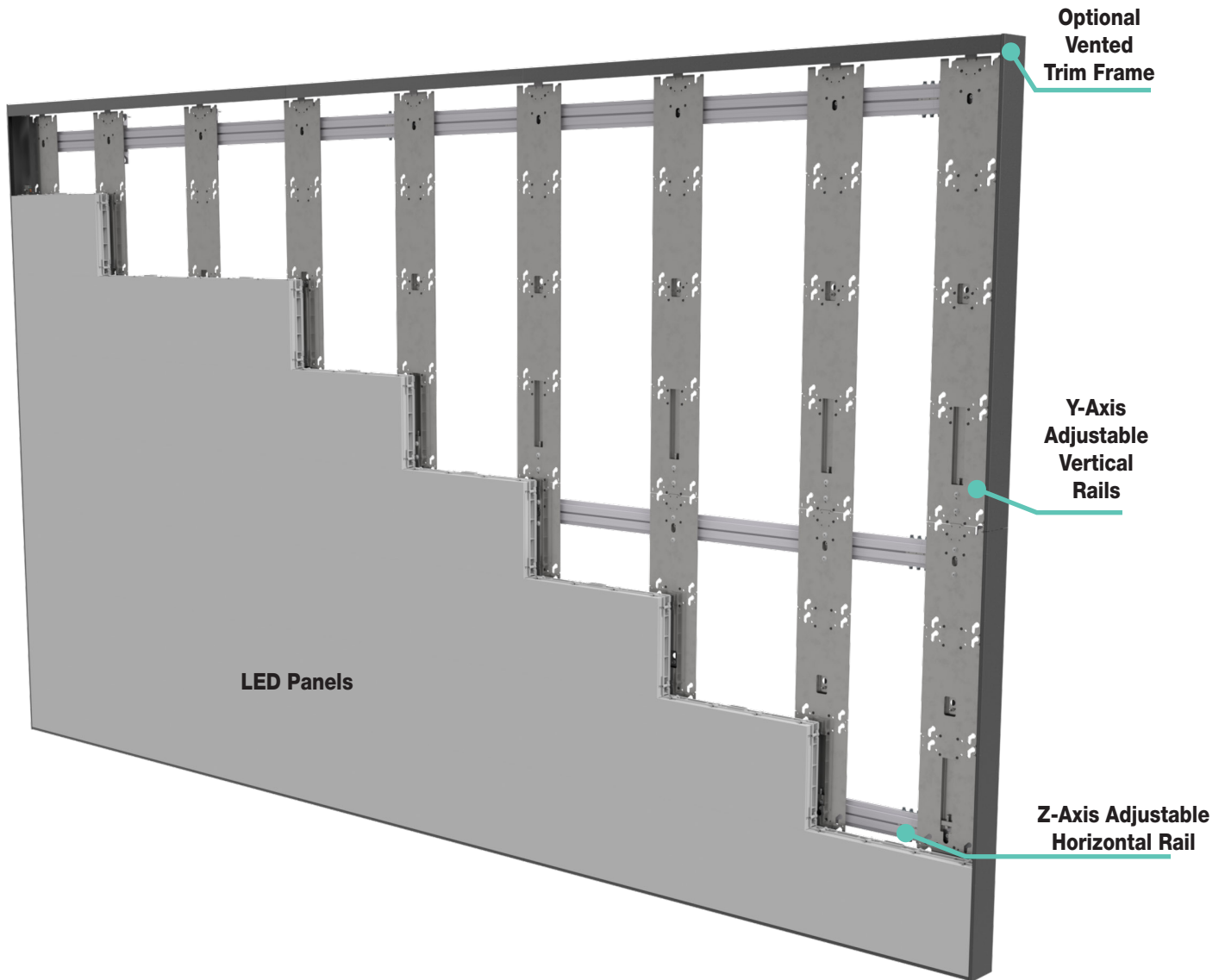

Section 1 - **Personnel and Tools Required**

**PERSONNEL REQUIRED**

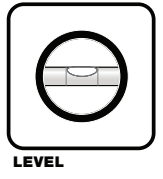
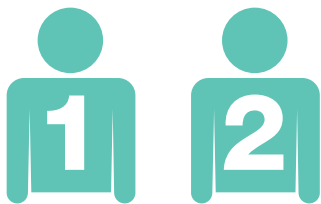

If you have any difficulties installing or servicing your Foundation for LED Panels, call your dealer or Draper, Inc.

Section 2 - Components

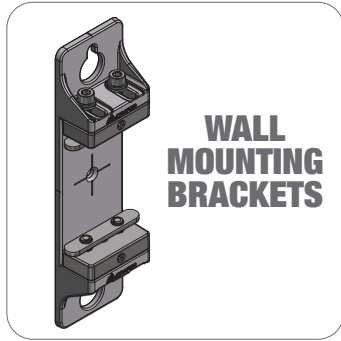

**WALL MOUNTING BRACKETS**

**HORIZONTAL RAILS**

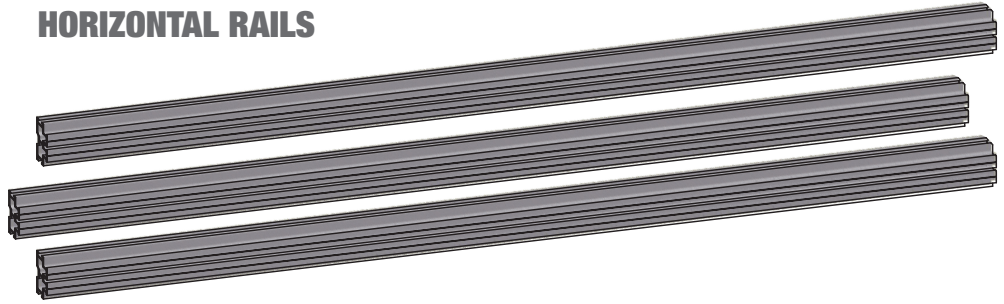

**VERTICAL RAILS**

**FOR 6 Panels High or Less**

**FOR 7 Panels High or Less**

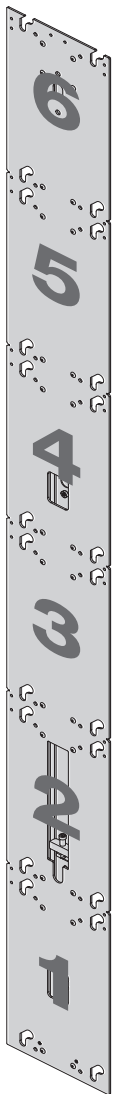

TOP VERTICAL RAIL  
Connects to BOTTOM VERTICAL RAIL  
with Vertical Rail Coupler

**VERTICAL RAIL FASTENERS**

SLIDE-IN NUT M6-1.0

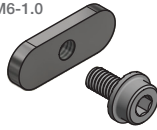

FLANGE HEAD SCREW M6-1.0x12mm

WALL ADJUSTMENT BRACKETS



Differential Screw  
3mm Hex Wrench

PLUM ALIGNMENT PIN



**HORIZONTAL RAIL CONNECTORS**

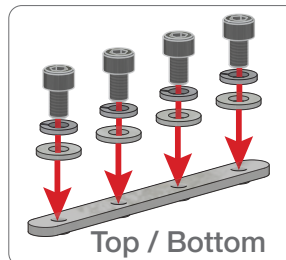

SCREW M6 - 1x10mm **x4**



SPLIT LOCK WASHER **x4**  
.25" ID X .365" OD X .063"



WASHER **x4**  
.255" ID X .562" OD X .06"

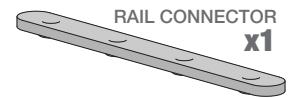

RAIL CONNECTOR **x1**

Front

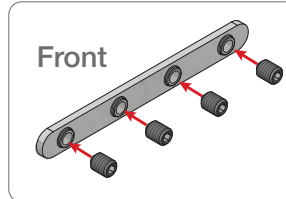

SET SCREW M6 - 1x8mm **x4**

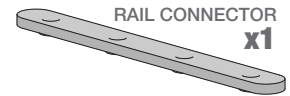

RAIL CONNECTOR **x1**

**LED MOUNTING & ALIGNMENT**

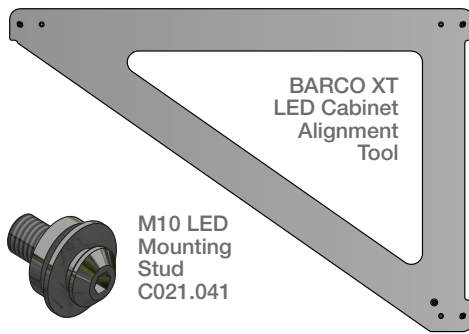

BARCO XT LED Cabinet Alignment Tool

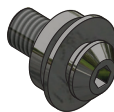

M10 LED Mounting Stud C021.041



**BARCO XT Series LED Cabinets**

(Not Included)

**VERTICAL RAIL COUPLER**

7 Panels High or More



BUTTON-HEAD SCREW M8-1.25x10mm Long Flanged **x2**

Component	Part #	Standard Array Size					
		4 X 4	5 X 5	6 X 6	8 X 8	10 X 10	12 X 12
<b>LED Panels</b>	<b>By Others</b>	16	25	36	64	100	144
<b>WALL MOUNTING BRACKETS</b>	<b>C002.1603</b>	8	10	12	24	30	36
<b>WALL ADJUSTERS</b>							
Wall Adjuster Bracket	<b>C002.1604.02SA</b>	10	12	14	27	33	39
Differential Socket Screw: M6 - 1x32.6mm	<b>C020.725</b>	10	12	14	27	33	39
<b>HORIZONTAL RAILS</b>							
90" (2286mm) Horizontal Rail	<b>C285.062.001</b>	0	2	2	0	6	8
93" (2362mm) Horizontal Rail	<b>C285.062.002</b>	2	0	0	6	0	0
Horizontal Rail Section (length varies)	<b>C285.062</b> <b>Length</b>	0 0mm	2 688mm	2 1297mm	0 0mm	3 1453mm	3 388mm
<b>HORIZONTAL RAIL CONNECTOR - Top/Bottom</b>							
Washer: .255"ID X .562"OD X .06"	<b>C013.012</b>	10	28	30	75	81	111
Split Lock Washer: .25" ID X .365"OD X .063"	<b>C013.028</b>	10	28	30	75	81	111
Screw: M6 - 1x10mm	<b>C020.729</b>	0	16	16	48	48	72
<b>HORIZONTAL RAIL CONNECTOR - Front</b>							
Horizontal Rail Connector	<b>C162.032</b>	0	6	6	18	18	27
Set Screw: M6 - 1x8mm	<b>C020.728</b>	0	8	8	24	24	33
<b>VERTICAL RAIL FASTENERS</b>							
Slide-In Nut: M6	<b>C018.165</b>	10	12	14	27	33	39
Flanged Socket Head Screw: M6 - 1x9mm	<b>C020.735</b>	10	12	14	27	33	39
<b>LED ALIGNMENT &amp; ATTACHMENT TOOLS</b>							
M10 Spring Loaded LED Mounting Stud	<b>C021.041</b>	64	100	144	256	400	576
LED Plum Alignment Pin	<b>C032.126</b>	6	6	6	9	9	9
LED Alignment Tool	<b>C202.039</b>	2	2	2	2	2	2
<b>VERTICAL RAILS</b>							
Vertical Rail Coupler	<b>C010.588</b>	0	0	0	9	11	13
Flanged Button Head Screw: M8 - 1.25x10mm	<b>C020.727</b>	0	0	0	36	44	52
Vertical Rail: 4 High Array / Lower for 8 High Array	<b>C056.070SA</b>	5	0	0	9	0	0
Vertical Rail: 5 High Array / Lower for 10 High Array	<b>C056.071SA</b>	0	6	0	0	11	0
Vertical Rail: 6 High Array / Lower for 12 High Array	<b>C056.072SA</b>	0	0	7	0	0	13
Vertical Rail: Upper for 8 High Array	<b>C056.074SA</b>	0	0	0	9	0	0
Vertical Rail: Upper for 10 High Array	<b>C056.075SA</b>	0	0	0	0	11	0
Vertical Rail: Upper for 12 High Array	<b>C056.076SA</b>	0	0	0	0	0	13

Section 2 (continued) - Trim Frame Components

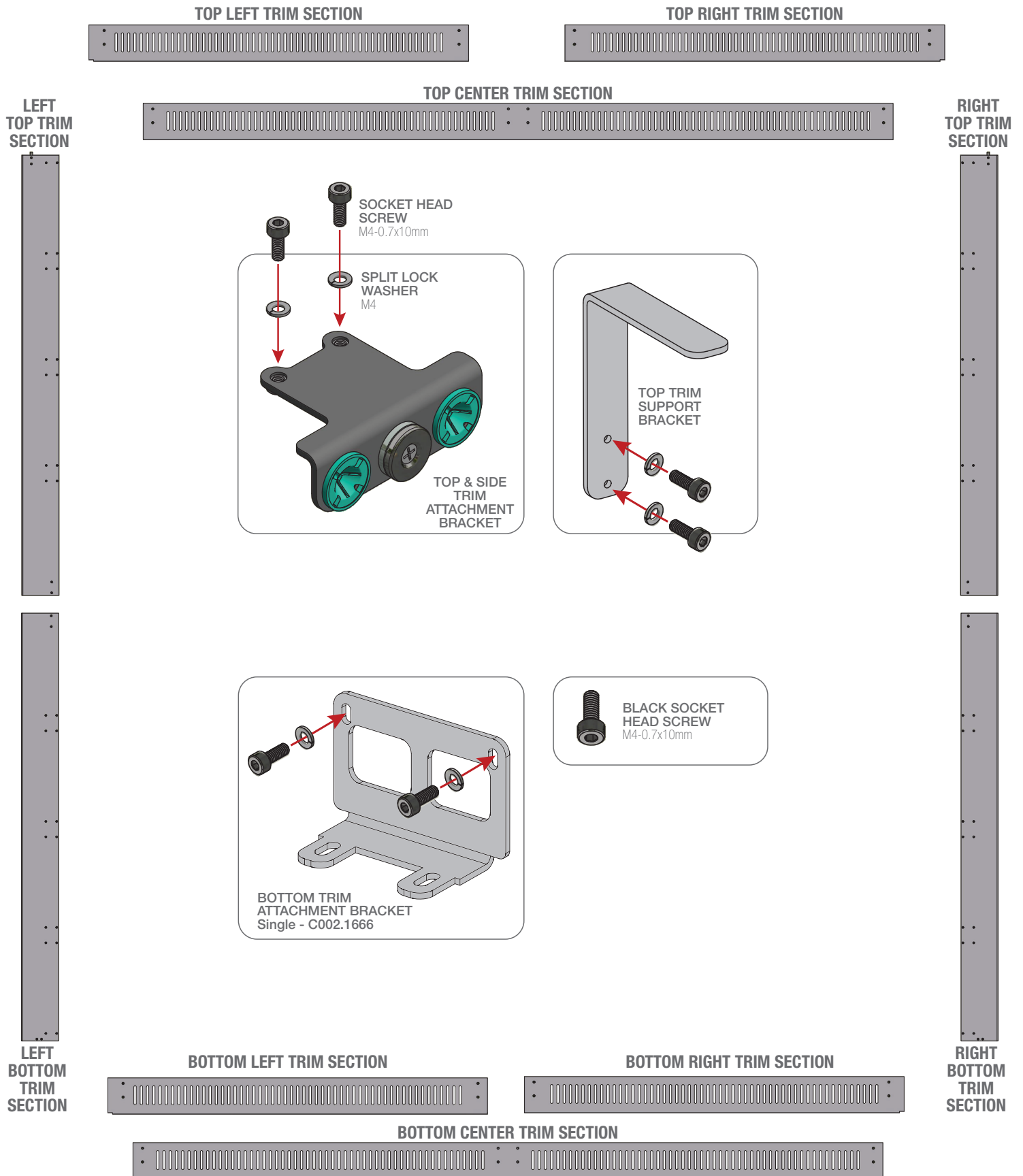

Trim Component	Part #	Standard Array Size					
		4 X 4	5 X 5	6 X 6	8 X 8	10 X 10	12 X 12
<b>TOP/SIDE TRIM BRACKETS</b>							
Top Trim Support Bracket	C002.1639.02SA	3	3	3	4	5	6
Trim Attachment Bracket (Top & Side)	C002.1609SA	11	14	17	23	29	36
Screw: M4 - 0.7x10mm	C020.621	32	40	48	64	82	94
Split Lock Washer: M4	C013.196	32	40	48	64	82	94
<b>BOTTOM TRIM BRACKETS</b>							
Bottom Trim Attachment Bracket	C002.1638.02SA	5	6	7	9	11	13
Screw: M4 - 0.7x8mm Black Oxide	C020.739	4	4	4	6	8	8
<b>TRIM SECTIONS</b>							
TRIM - TOP CENTER	C287.147SA	0	0	0	1	2	0
TRIM - TOP CENTER	C287.148SA	0	0	0	0	0	2
TRIM - TOP LEFT	C287.149SA	1	0	0	0	0	0
TRIM - TOP LEFT	C287.150SA	0	1	1	1	1	1
TRIM - TOP RIGHT	C287.151SA	1	1	0	0	0	0
TRIM - TOP RIGHT	C287.152SA	0	0	1	1	1	1
TRIM - LT SIDE	C287.122SA	1	0	0	0	0	0
TRIM - LT SIDE	C287.123SA	0	1	0	0	0	0
TRIM - LT SIDE	C287.124SA	0	0	1	0	0	0
TRIM - LEFT SIDE BOTTOM	C287.126SA	0	0	0	1	0	0
TRIM - LEFT SIDE BOTTOM	C287.127SA	0	0	0	0	1	0
TRIM - LEFT SIDE BOTTOM	C287.128SA	0	0	0	0	0	1
TRIM - LEFT SIDE TOP	C287.130SA	0	0	0	1	0	0
TRIM - LEFT SIDE TOP	C287.131SA	0	0	0	0	1	0
TRIM - LEFT SIDE TOP	C287.132SA	0	0	0	0	0	1
TRIM - RIGHT SIDE BOTTOM	C287.134SA	0	0	0	1	0	0
TRIM - RIGHT SIDE BOTTOM	C287.135SA	0	0	0	0	1	0
TRIM - RIGHT SIDE BOTTOM	C287.136SA	0	0	0	0	0	1
TRIM - RIGHT SIDE TOP	C287.138SA	0	0	0	1	0	0
TRIM - RIGHT SIDE TOP	C287.139SA	0	0	0	0	1	0
TRIM - RIGHT SIDE TOP	C287.140SA	0	0	0	0	0	1
TRIM - RIGHT SIDE	C287.144SA	1	0	0	0	0	0
TRIM - RIGHT SIDE	C287.145SA	0	1	0	0	0	0
TRIM - RIGHT SIDE	C287.146SA	0	0	1	0	0	0
TRIM - BOTTOM CENTER	C287.113SA	0	0	0	1	2	0
TRIM - BOTTOM CENTER	C287.114SA	0	0	0	0	0	2
TRIM - BOTTOM LEFT	C287.115SA	1	0	0	0	0	0
TRIM - BOTTOM LEFT	C287.116SA	0	1	1	1	1	1
TRIM - BOTTOM RIGHT	C287.117SA	1	1	0	0	0	0
TRIM - BOTTOM RIGHT	C287.118SA	0	0	1	1	1	1

Section 3 - **Determining Horizontal Mounting Location**

**Section 3.1 - For LED arrays up to 6 panels high - 2 Horizontal Rails**

The Foundation Wall Brackets must be securely anchored to the wall. If mounting to drywall/gypsum board wall, all mounting hardware (by others) must be anchored to a vertical stud. If mounting to a brick or block wall, the brackets must be evenly spaced no more than 32" (813mm) apart. In the drawings showing in this manual, the bracket spacing is 24" unless specified otherwise.

The example below is for a 6 x 6 Array. Other standard 2 rail array sizes (4x4 & 5x5) are shown in the table at right.

1. Mark the location of the **Bottom Left Corner** of the **viewing area**.
2. From the mark made in step 1, measure up **19 1/4" (490mm)** and draw a level horizontal line the width of the LED display.  
This is the top mounting hole location of the **WALL MOUNTING BRACKET FOR THE BOTTOM HORIZONTAL RAIL** (see Mounting Bracket Detail at right).
3. Use the chart at right to determine the proper value for **Dim A**.  
From the mark made in step 1, measure up (*Dimension A from chart at right*) and draw a level horizontal line the width of the LED display.  
This is the top mounting hole location of the **WALL MOUNTING BRACKET FOR THE TOP HORIZONTAL RAIL** (see Mounting Bracket Detail at right).

The fully assembled Horizontal Rails (see section 4) will be hung from them in Section 5.

Fig. 3.1

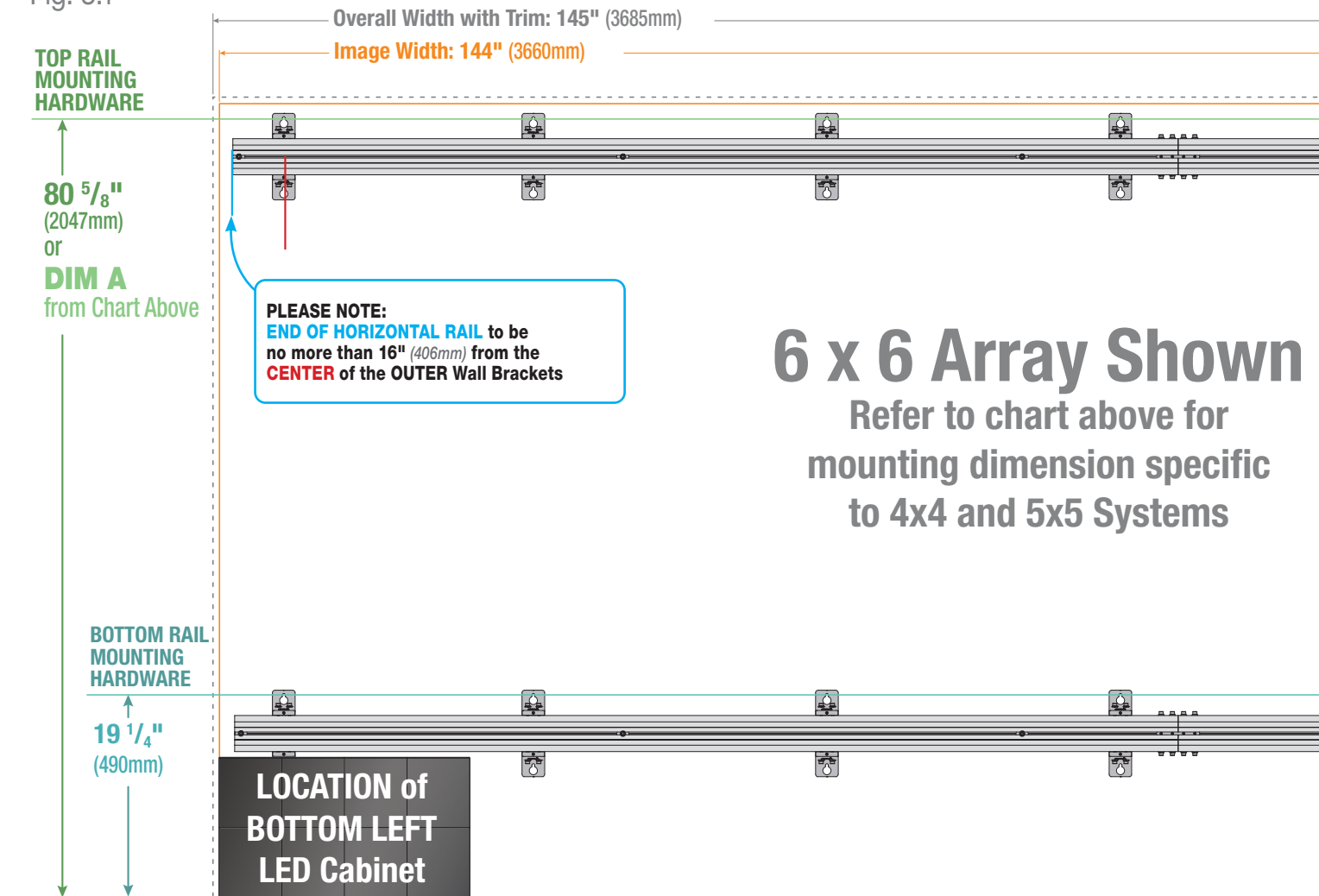

**START HERE**

LOCATE BOTTOM LEFT of **Image Area** ———  
or  
LOCATE BOTTOM LEFT of **Trim** - - - - -

NOTE: If installing trim, you must allow 1 5/16" (33mm) of clearance around th



### STANDARD ARRAY MOUNTING DIMENSIONS

Array Size	DIM A	FINAL VIEWING AREA	
	Vertical distance from Bottom Left of to Top Rail Mounting Hardware	HEIGHT	WIDTH
4x4	53 3/8" (1357mm)	54" (1374mm)	96 1/16" (2440mm)
5x5	67" (1704mm)	67 1/2" (1714mm)	120" (3050mm)
6x6	80 5/8" (2047mm)	81 1/8" (2061mm)	144" (3660mm)

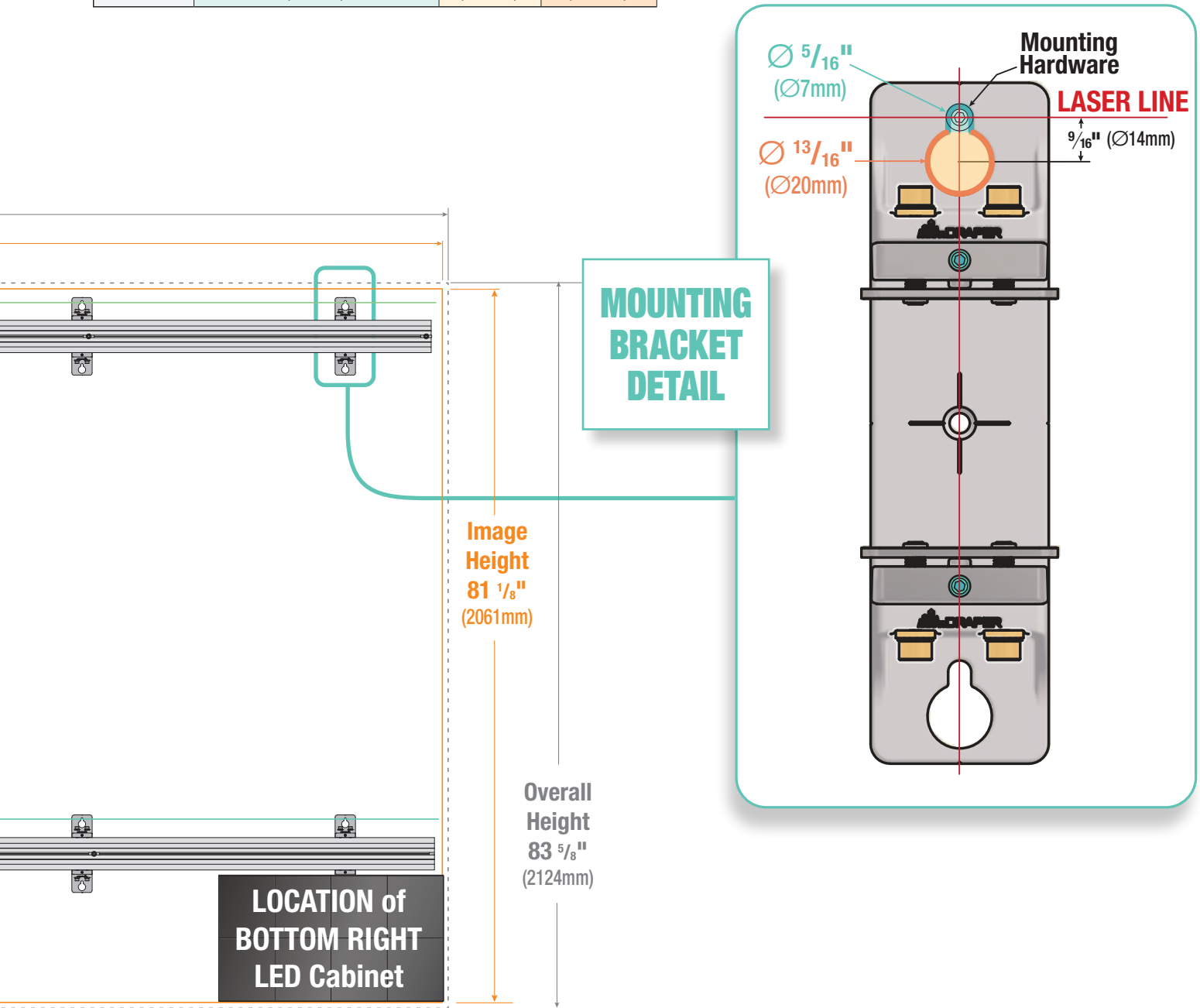

outside of the image area.

**Section 3.2 - For LED arrays 7 panels or higher - 3 Horizontal Rails**

The Foundation Wall Brackets must be securely anchored to the wall. If mounting to drywall/gypsum board wall, all mounting hardware (by others) must be anchored to a vertical stud. If mounting to a brick or block wall, the brackets must be evenly spaced no more than 32" (813mm) apart. If installing trim, you must allow 1 5/16" (33mm) of clearance around the outside of the VIEWING AREA.

The example below is for a 8 x 8 Array. Dimensions for other standard 3 rail array sizes (10x10 and 12x12) are shown in the table at right.

1. Mark the location of the **Bottom Left Corner** of the viewing area.
2. From the mark made in step 1, measure up **19 1/4" (490mm)** and draw a level horizontal line the width of the LED display.  
This is the top mounting hole location of the **WALL MOUNTING BRACKET FOR THE BOTTOM HORIZONTAL RAIL** (see Mounting Bracket Detail at right).
3. From the mark made in step 1, measure up **53 3/8" (1358mm)** and draw a level horizontal line the width of the LED display.  
For 10x10 or 12x12 arrays, use the chart at right to determine the proper value for **Dim A**.
4. From the mark made in step 1, measure up **107 11/32" (2727mm)** and draw a level horizontal line the width of the LED display.  
This is the top mounting hole location of the **WALL MOUNTING BRACKET FOR THE TOP HORIZONTAL RAIL** (see Mounting Bracket Detail at right).  
For 10x10 or 12x12 arrays, use the chart at right to determine the proper value for **Dim B**.

The fully assembled Horizontal Rails (see section 4) will be hung from them in Section 5.

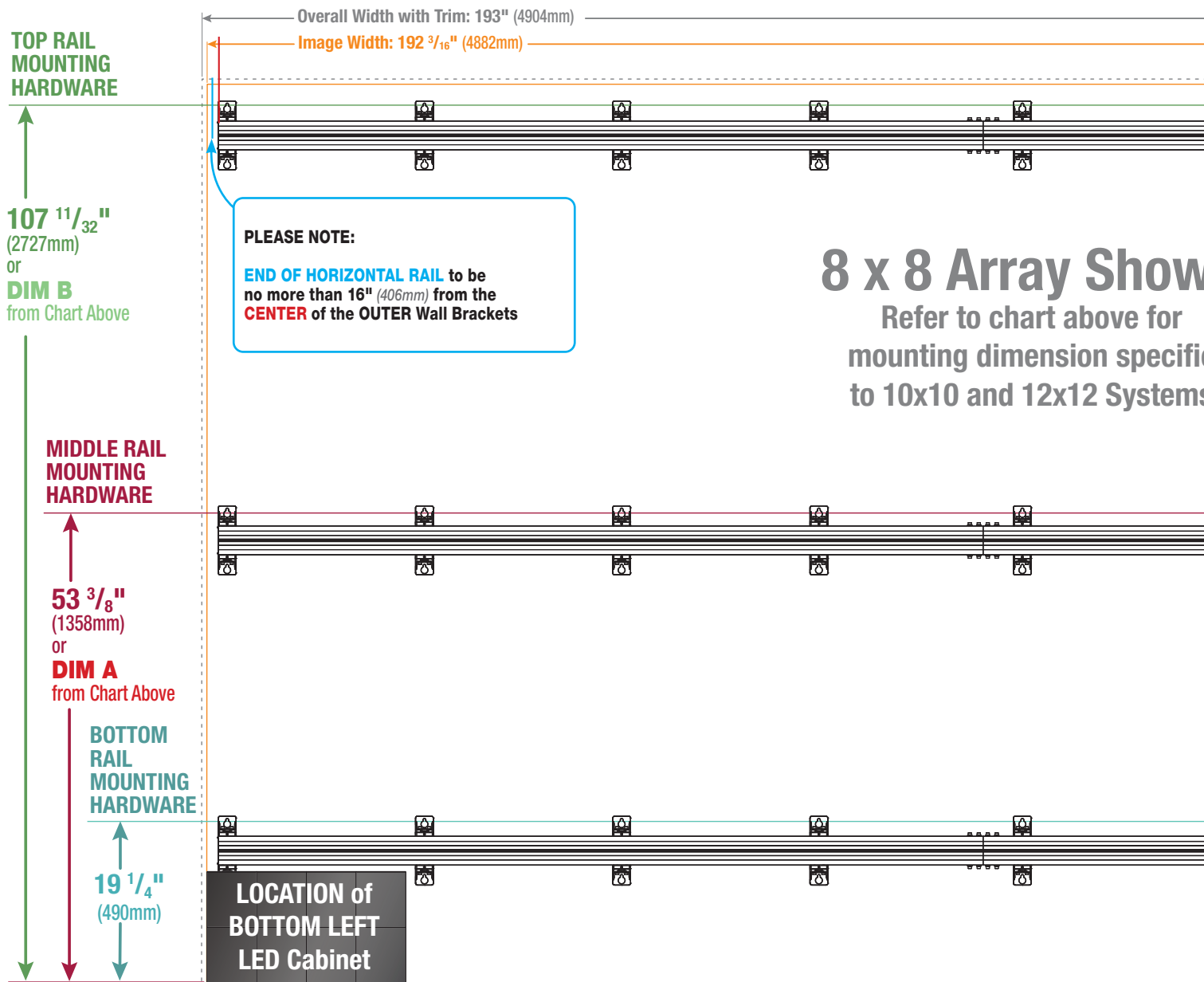

**8 x 8 Array Show**  
Refer to chart above for mounting dimension specific to 10x10 and 12x12 Systems

**START HERE**  
LOCATE BOTTOM LEFT of **Image Area** ———  
or  
LOCATE BOTTOM LEFT of **Trim** - - - - -

**NOTE:** If installing trim, you must allow 1 5/16" (33mm) of clearance around the outside of the viewing area.

## STANDARD ARRAY MOUNTING DIMENSIONS

Array Size	DIM A	DIM B	FINAL VIEWING AREA	
	Vertical distance from Bottom Left of Array to Middle Rail Mounting Hardware	Vertical distance from Bottom Left of Array to Top Rail Mounting Hardware	HEIGHT	WIDTH
8x8	53 <sup>3</sup> / <sub>8</sub> " (1358mm)	107 <sup>3</sup> / <sub>8</sub> " (2727mm)	108 <sup>1</sup> / <sub>16</sub> " (2747mm)	192 <sup>3</sup> / <sub>16</sub> " (4882mm)
10x10	67" (1704mm)	134 <sup>7</sup> / <sub>16</sub> " (3413mm)	135 <sup>1</sup> / <sub>8</sub> " (3433mm)	240 <sup>1</sup> / <sub>4</sub> " (6102mm)
12x12	80 <sup>5</sup> / <sub>8</sub> " (2047mm)	161 <sup>13</sup> / <sub>32</sub> " (4100mm)	162 <sup>1</sup> / <sub>8</sub> " (4119mm)	288 <sup>1</sup> / <sub>2</sub> " (7322mm)

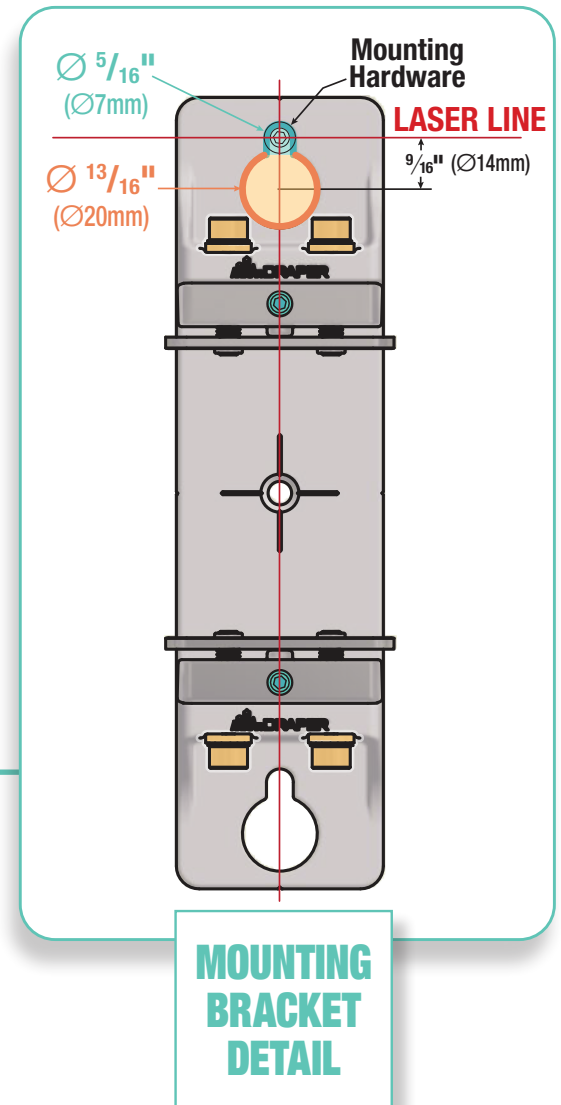
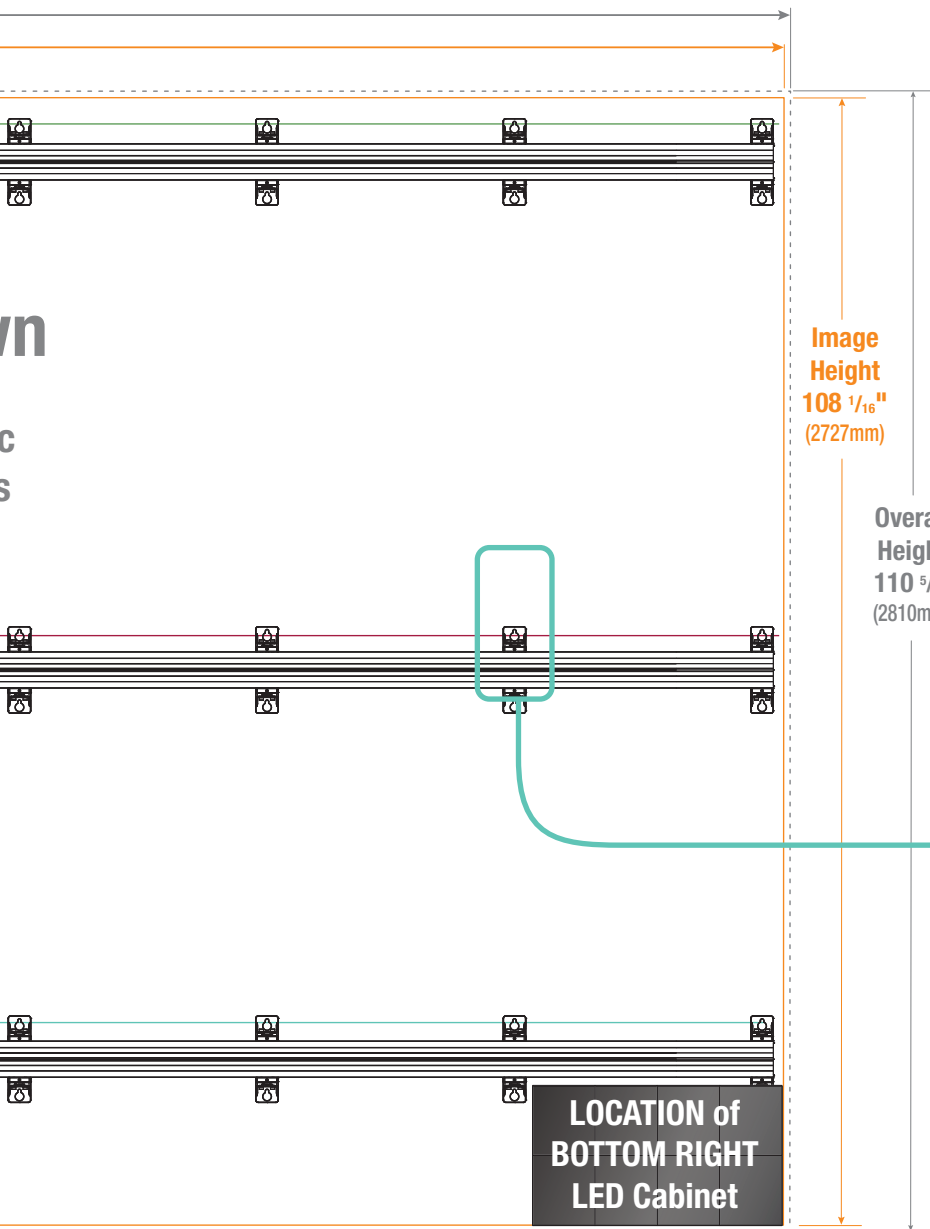

around the outside of the image area.

**Section 3.2 - Marking Vertical Mounting locations**

**Section 3.2.1 - WOOD/METAL STUD INSTALLATION**

1. Locate the wall studs and mark their location at the intersection of the lines drawn in Section 3.1.

Fig. 3.2-1

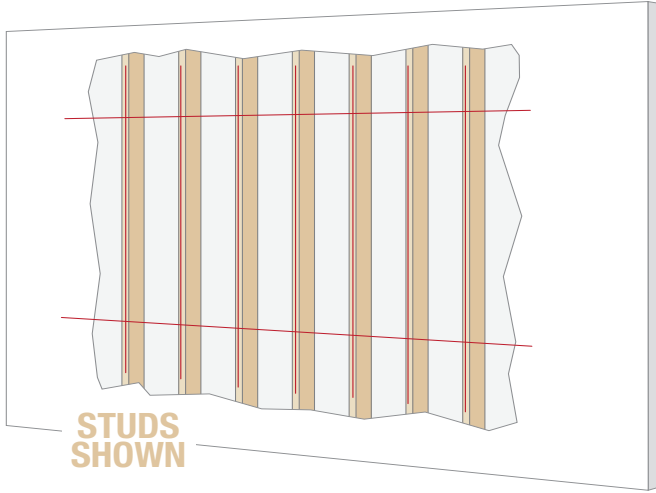

**Section 3.2.2 - CONCRETE, BLOCK OR BRICK INSTALLATION**

1. Draw vertical lines spaced 24" (609mm) to 32" (813mm) apart.

Fig. 3.2-2

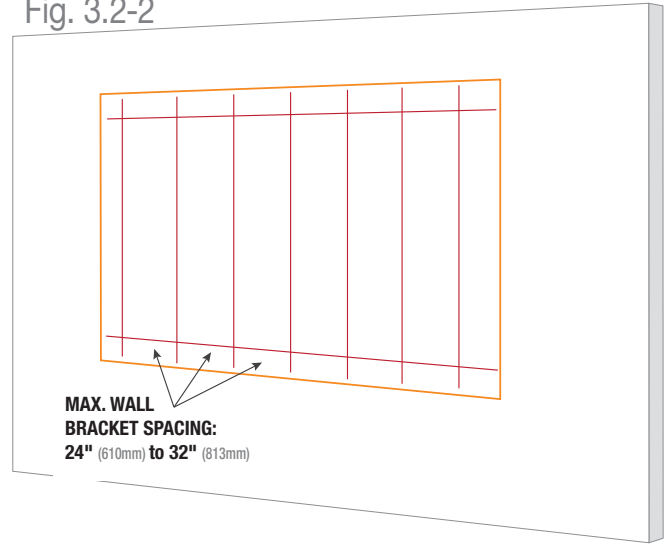

**Section 3.3 - Attaching Mounting Hardware (by Others) to Wall**

1. Loosely attach the wall mounting hardware (provided by others) to the wall at the outer four corners of the grid created in Sections 3.1 & Section 3.2. Ensure the head of the hardware is at least 1/2" (12mm) off the surface of the wall.

The assembled Horizontal Rails will be hung from these in SECTION 5 - Hanging Horizontal Rails.

Fig. 3.3

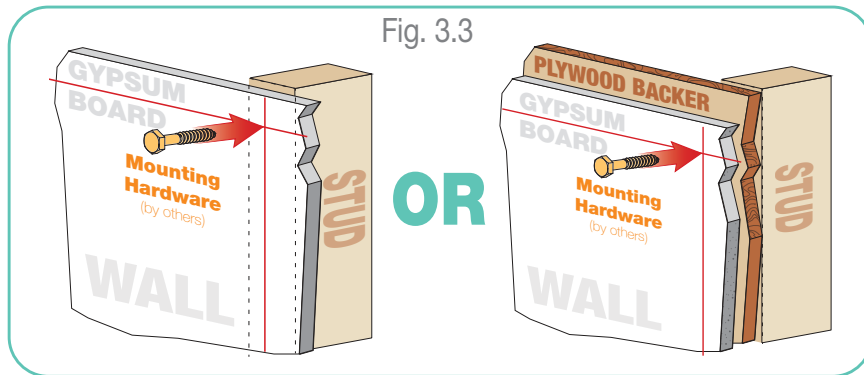

**MOUNTING LAG SCREW**  
BY OTHERS MIN: .25" x 1.75" L

Must attach to studs or  
1/2" Plywood Backer

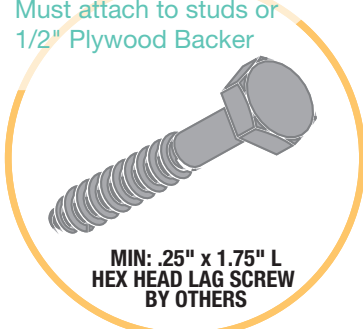

**Please Note:** It is the responsibility of the installer to select mounting hardware appropriate for the mounting surface

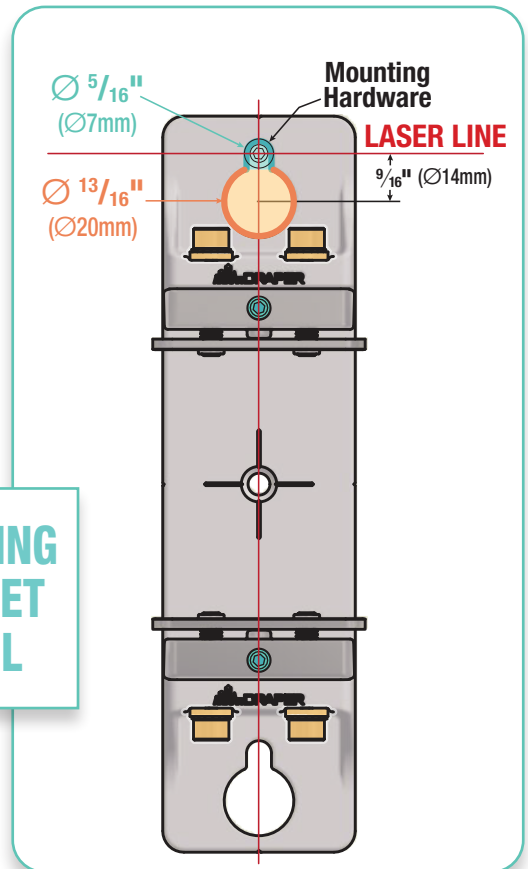

**MOUNTING BRACKET DETAIL**

### Section 4 - Assembling Horizontal Rails

The horizontal rails must be assembled prior to being secured to the wall.

A complete Horizontal Rail consists of Wall Mounting Brackets engaged in both TOP and BOTTOM Channels of extruded rail sections (see MOUNTING BRACKET DETAIL at right).

Horizontal rail sections are extended in length using 3 Horizontal Rail Connectors per splice.

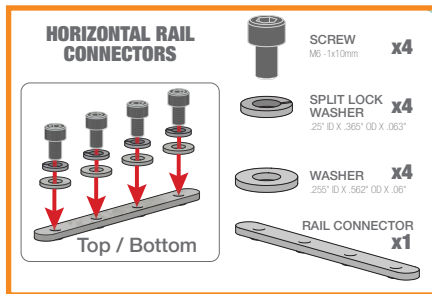

**Please Note:**  
Only the TOP and BOTTOM rail connectors will be used to assemble the rails.

Front Rail Connector will be installed later in Section 9.

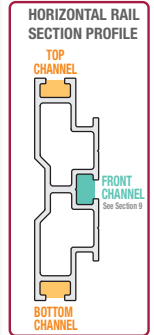
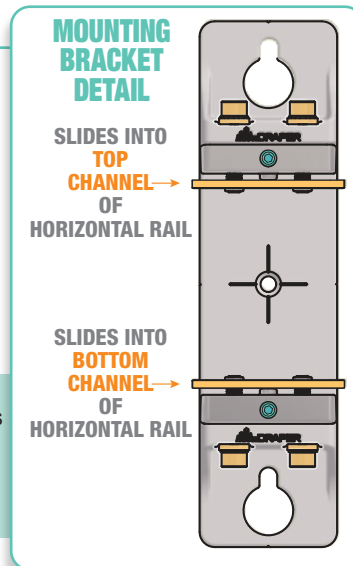

See chart above for the suggested number of wall brackets required per rail and splice locations.

#### STANDARD ARRAY SIZES - SUGGESTED BRACKETS REQUIRED & SPLICE LOCATIONS

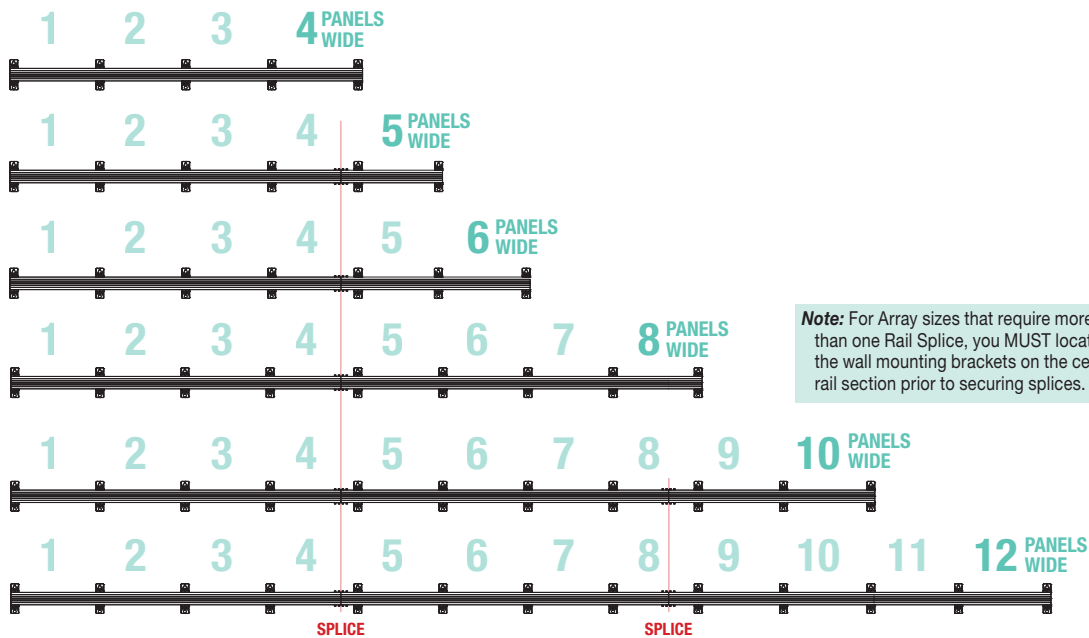

**Note:** For Array sizes that require more than one Rail Splice, you MUST locate the wall mounting brackets on the center rail section prior to securing splices.

#### To assemble the Horizontal rails:

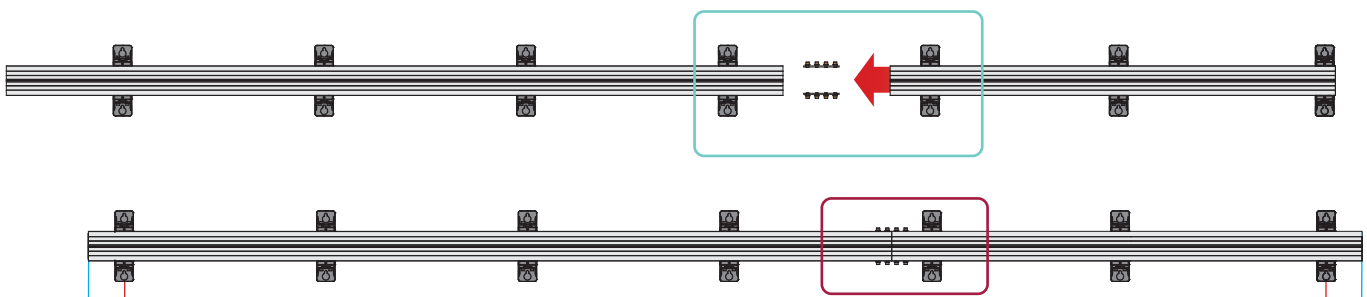
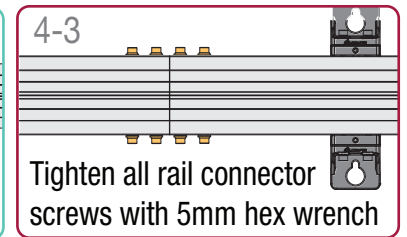
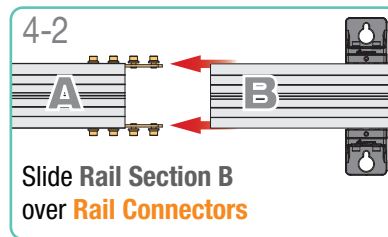
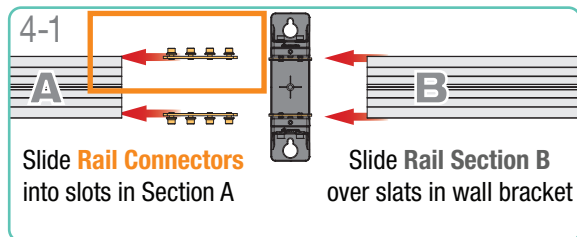

Section 5 - **Hanging Horizontal Rails**

**Section 5.1 - For LED arrays up to 6 panels high - 2 Horizontal Rails**

1. Using the top keyhole slots of the two outer wall mounting brackets, hang the bottom horizontal rail on the pre-installed mounting hardware (see Section 3, Step 5).

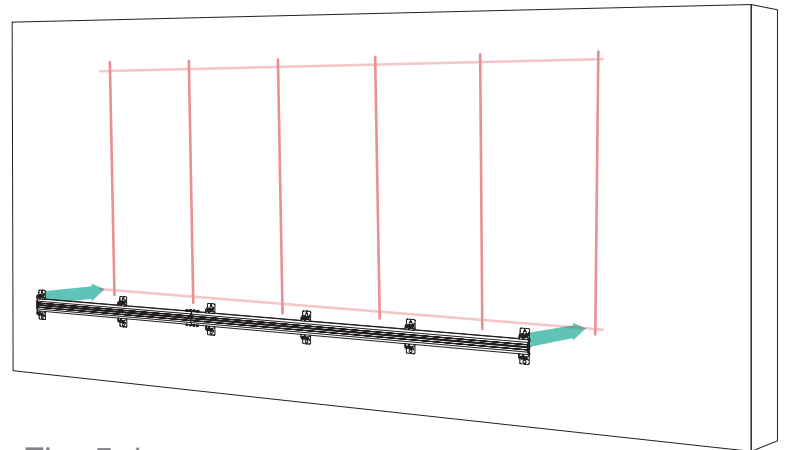
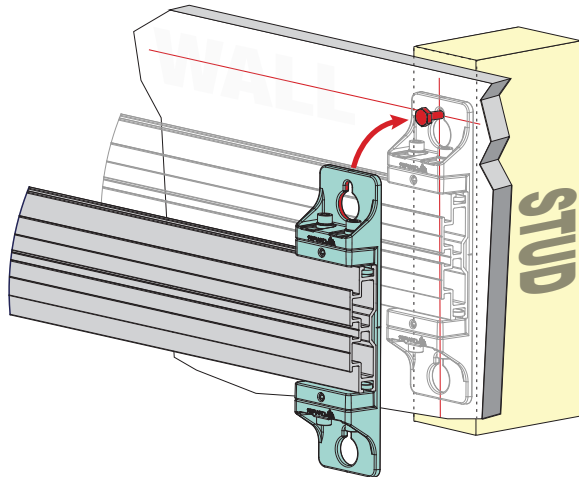

Fig. 5-1

2. Using the top keyhole slots of the outer wall mounting brackets, hang the top horizontal rails on the pre-installed mounting hardware.

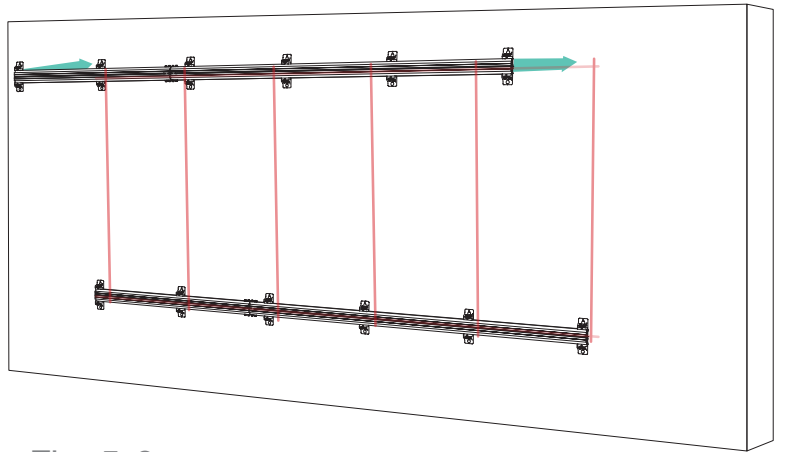

Fig. 5-2

3. Secure the outer wall mounting brackets on each end of the horizontal rails onto the wall. Leave the inner brackets loose for now.

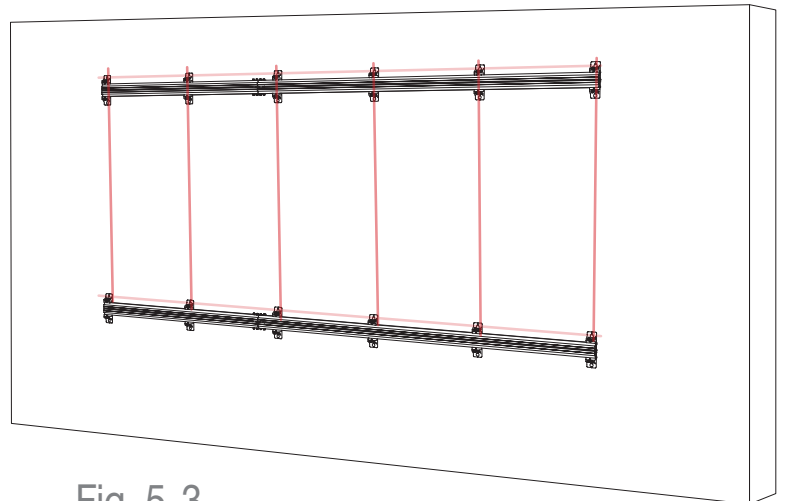
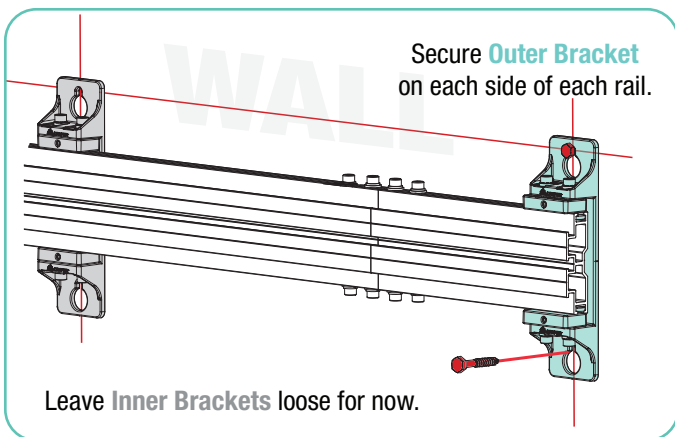
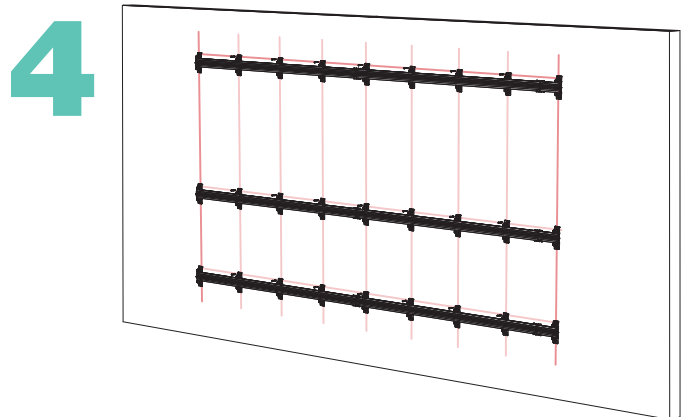
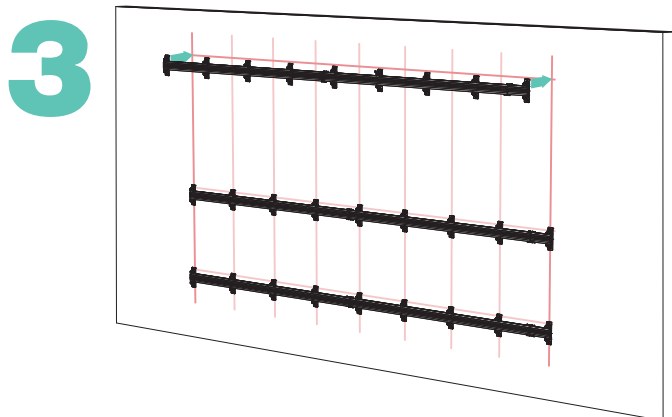
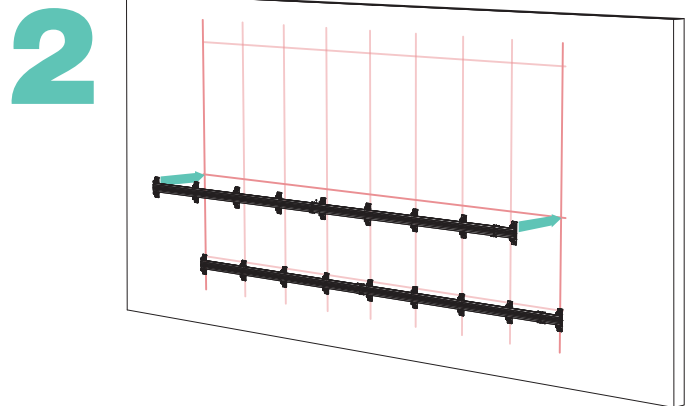
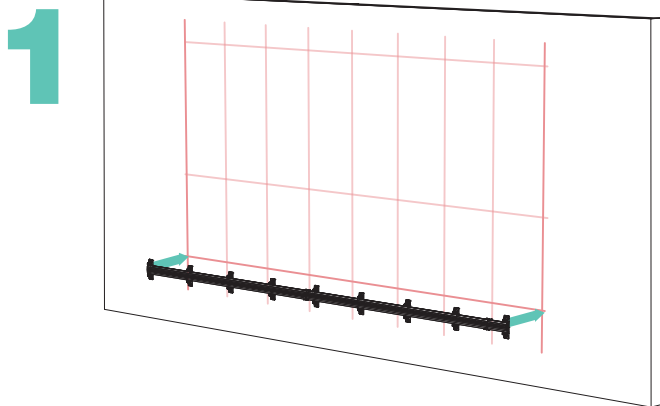
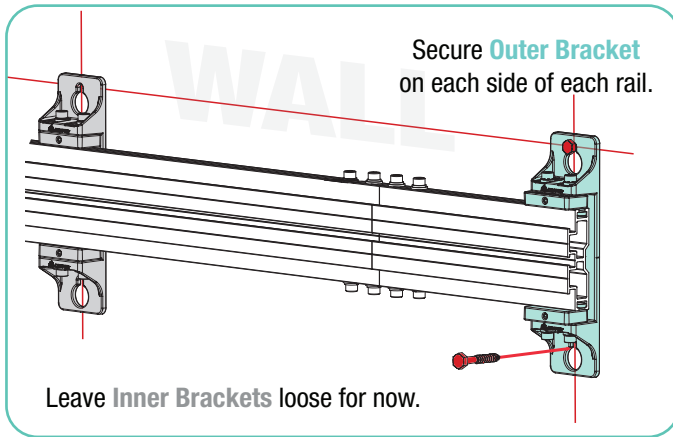
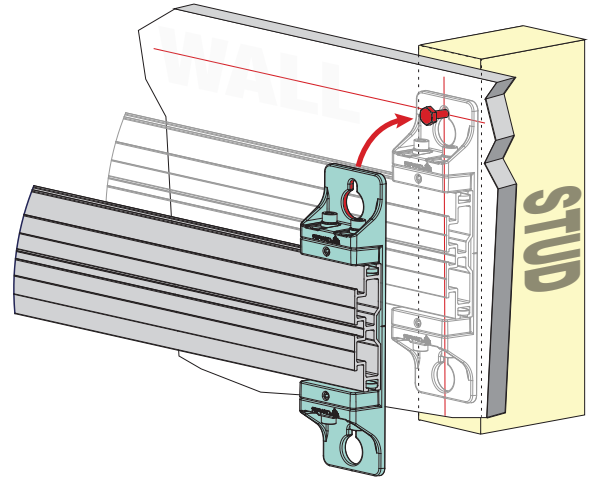

Fig. 5-3

**Section 5.2 - For LED arrays 7 panels or higher - 3 Horizontal Rails**

1. Using the top keyhole slots of the outer wall mounting brackets, hang the **BOTTOM** horizontal rail on the pre-installed mounting hardware (see Section, 3 Step 5).
2. Using the top keyhole slots of the outer wall mounting brackets, hang the **MIDDLE** horizontal rail on the pre-installed mounting hardware.
3. Using the top keyhole slots of the outer wall mounting brackets, hang the **TOP** horizontal rail on the pre-installed mounting hardware.
4. Secure the outer wall mounting brackets on each side of the horizontal rails. Leave the inner brackets loose for now.



Section 6 - **Adjusting and Aligning Horizontal Rails**

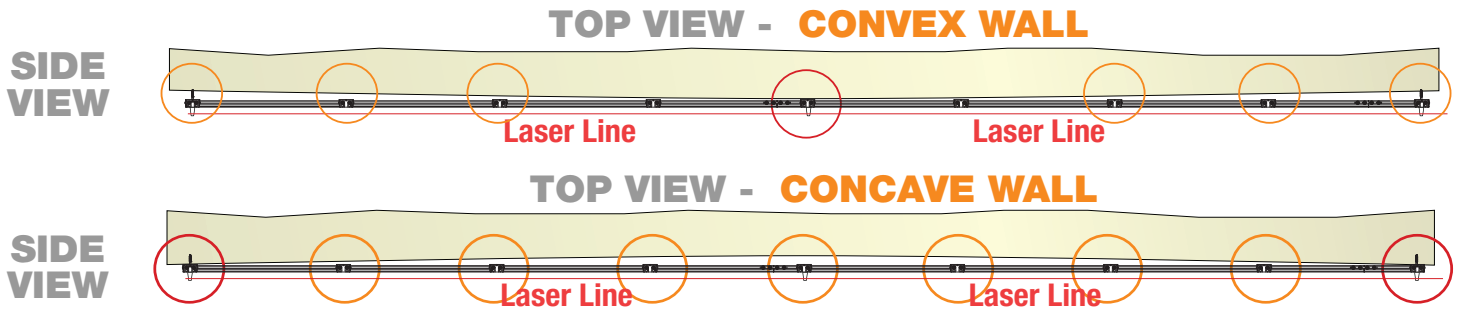

1. Position three (3) Plum Alignment Pins on each horizontal rail ensuring one is at the far left, center and far right.
2. Using a 5mm Hex Wrench, loosen the four (4) locking screws on the top and bottom of each of the four (4) outer wall mounting brackets.
3. Shine a laser level parallel to the wall with the laser intersecting the plum alignment pins.
4. Using a 3mm Hex Wrench, turn the two (2) adjustment set screws on each wall mounting bracket to position the Alignment Notch with the laser line  
*(Please Note: when setting the plumb adjustment, the face of the horizontal rail must remain plump and not twisted).*
5. Once the Laser Line and all Alignment Pins are aligned, tighten the four (4) locking screws on the top and bottom each of the outer mounting bracket.

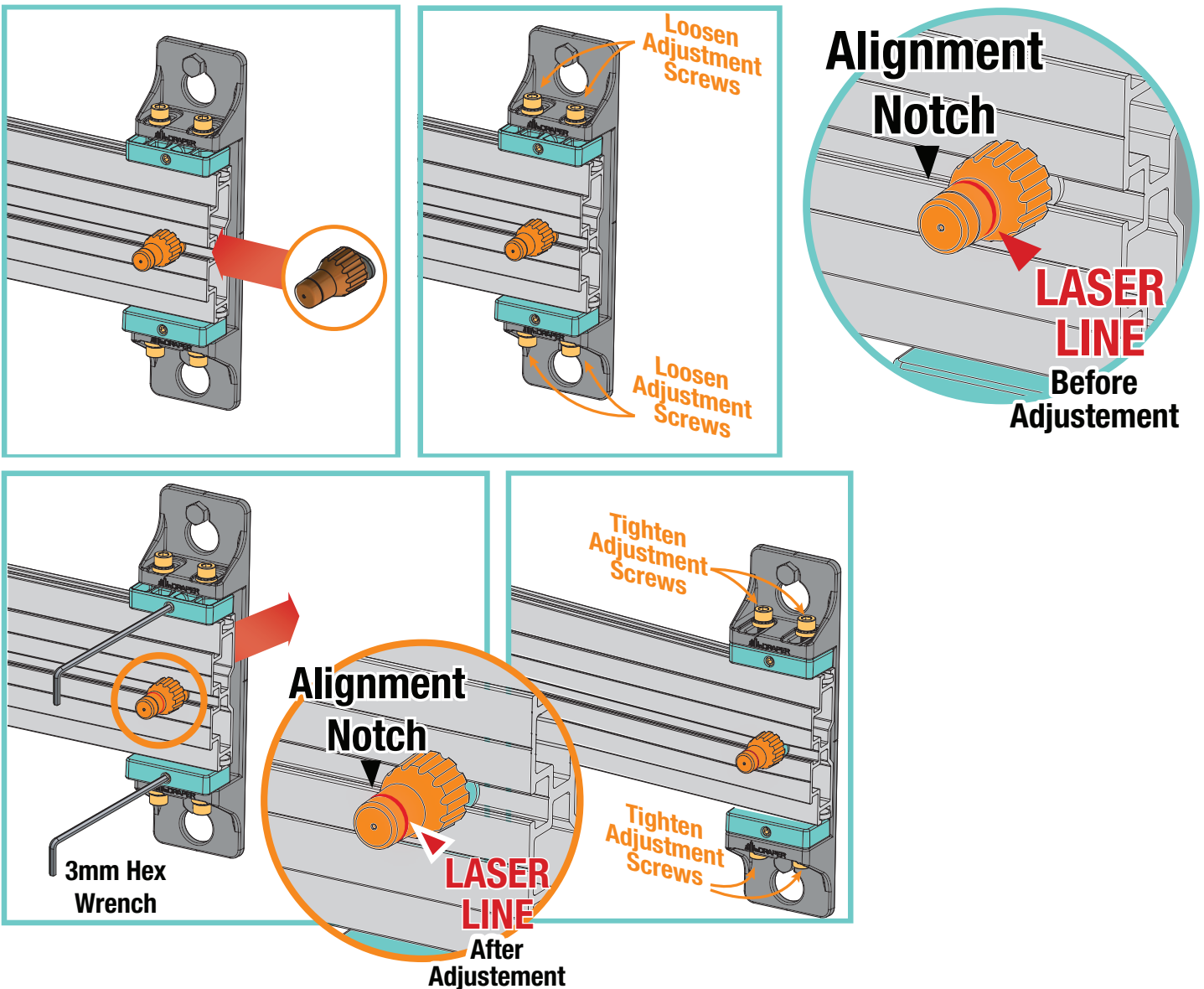



Section 7 - **Securing Inner Wall Brackets**

1. Using a 3mm Hex Wrench adjust all remaining wall mounting brackets. Ensure that each bracket is flush to the wall and secure to the wall with the appropriate mounting hardware.
2. Carefully tighten all four (4) locking screws on the top and bottom of each wall mounting bracket.
3. Repeat steps 1 and 2 until all brackets are plum and secured in place.

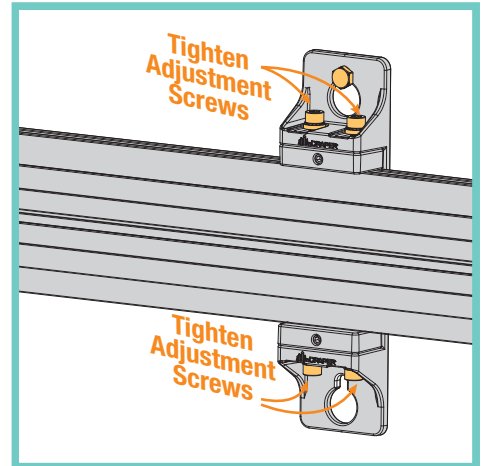
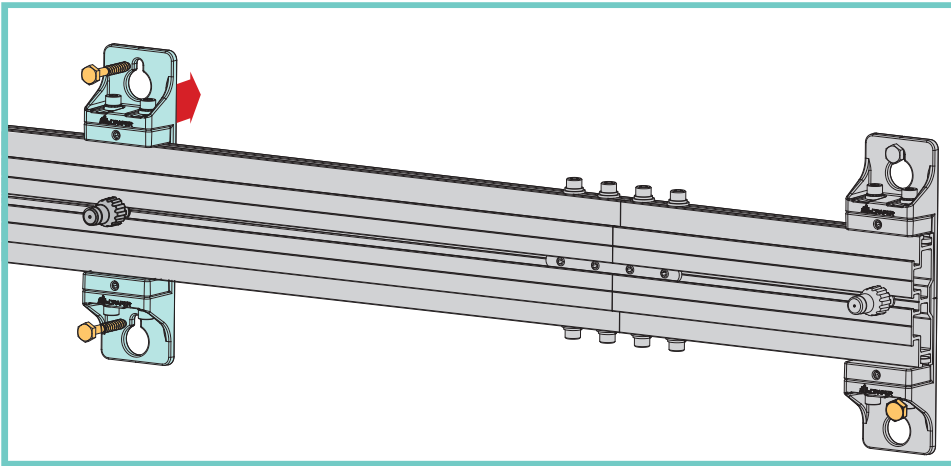

Section 8 - **Attaching Wall Adjuster Brackets to Vertical Rails**

WORK GLOVES RECOMMENDED

Section 8.1 - **For LED arrays up to 6 panels high - 2 Horizontal Rails**

1. Attach the Differential Screw to the Wall Adjustment Bracket.



2. Attach two (2) Wall Adjuster Brackets to the back side using a 3mm hex wrench.

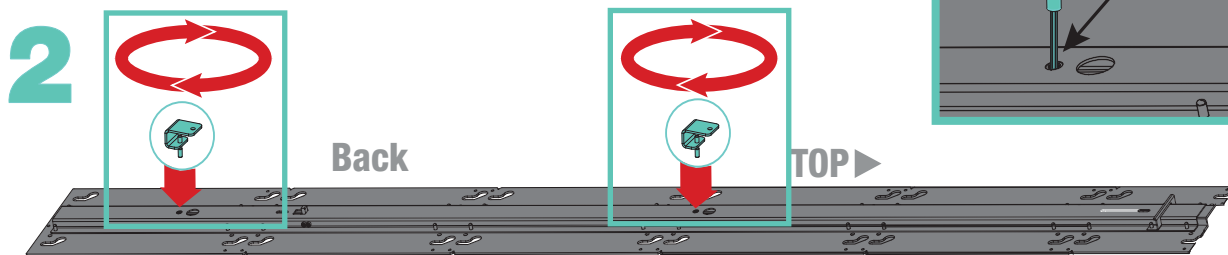



**Section 8.2 - Vertical Rail Assembly - For LED arrays 7 panels or higher - 3 Horizontal Rails**

**Section 8.2.1 - Lower Section of Vertical Rail Assembly**

1. Insert Vertical Connector into TOP of the Lower Vertical Rail section and secure with provided hardware (3mm Hex Wrench).

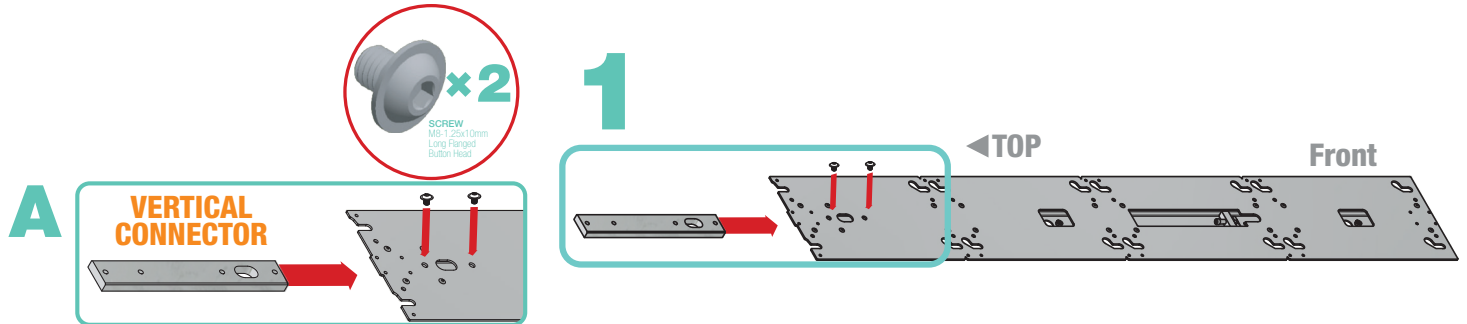

2. Turn the Lower Vertical Rail section over.



3. Attach two (2) Wall Adjuster Brackets to the back side using a 3mm hex wrench.

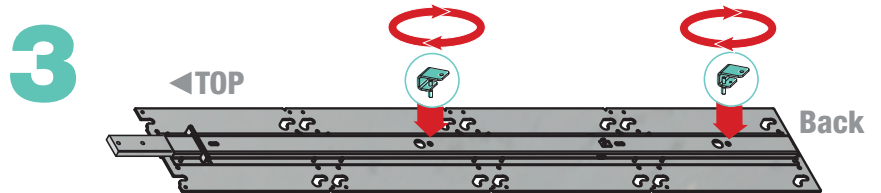

**Section 8.2.2 - Upper Section of Vertical Rail Assembly**

1. Attach one (1) Wall Adjuster Bracket to the back side using a 3mm hex wrench.

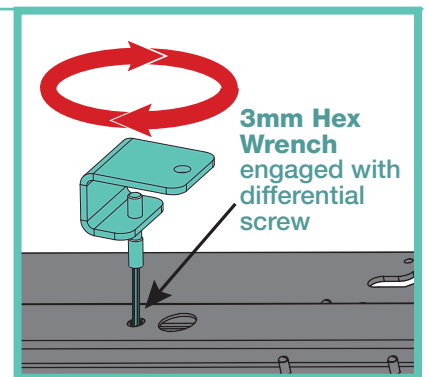

Section 9 - Inserting Front Rail Connector and Vertical Rail Fasteners

**Section 9.1 - For LED arrays up to 6 panels high - 2 Horizontal Rails**

1. Insert horizontal rail connector and vertical rail fasteners into the top and bottom horizontal rails.

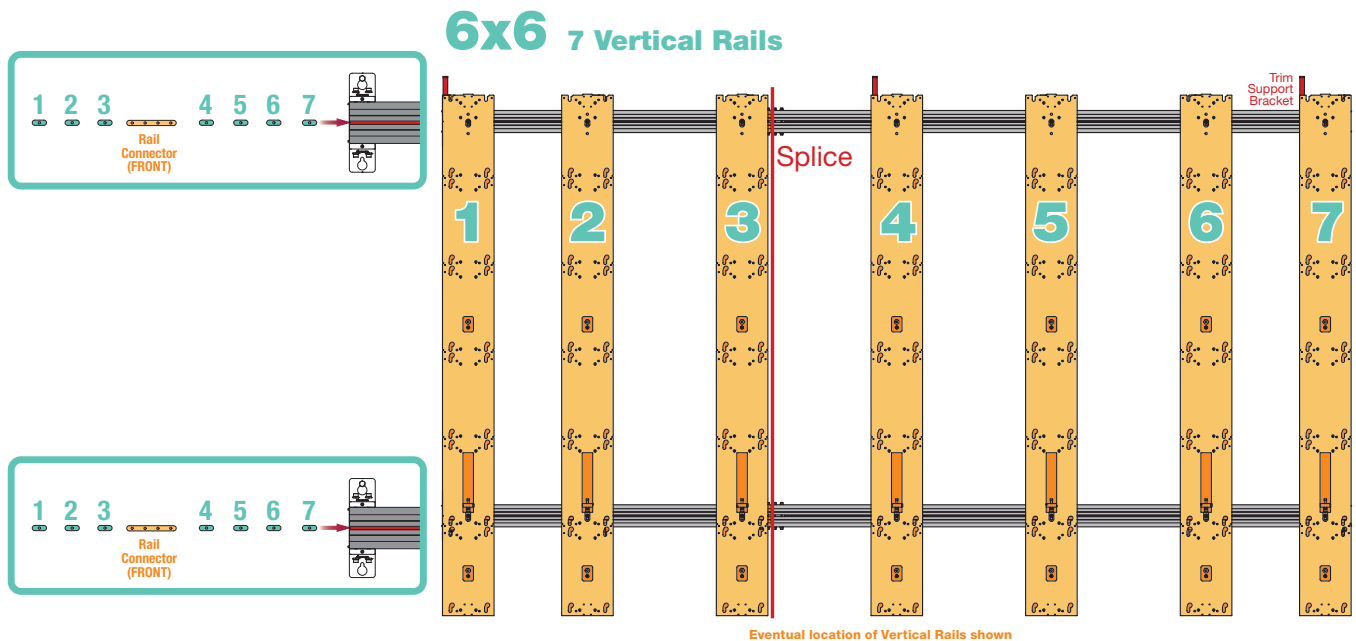
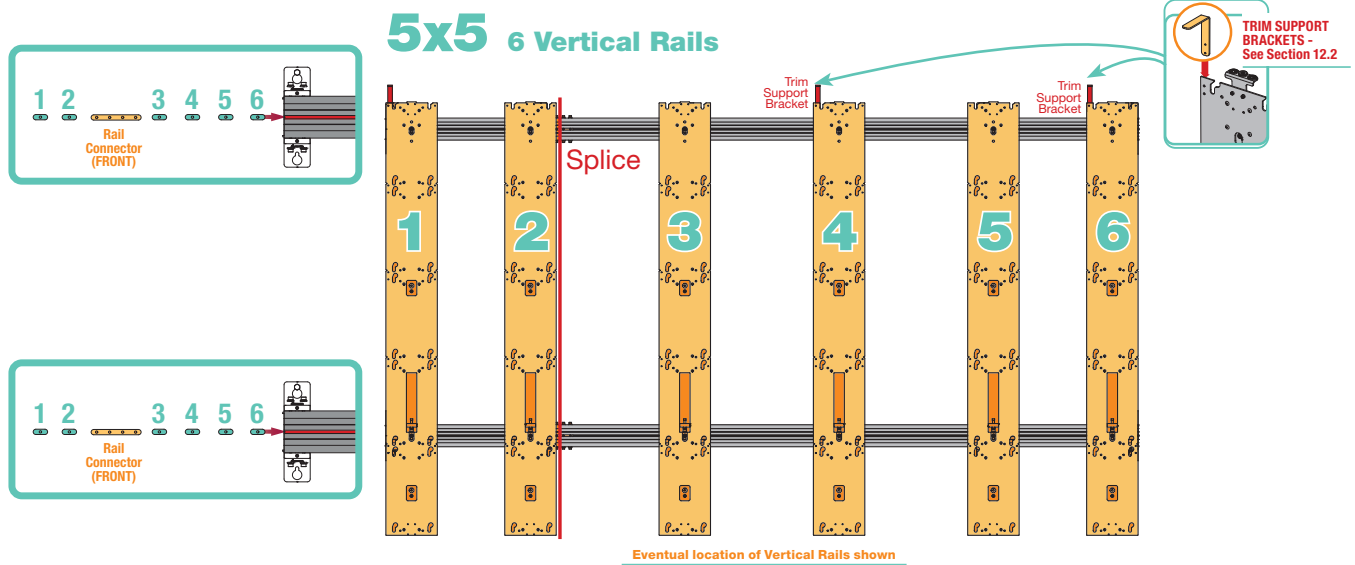
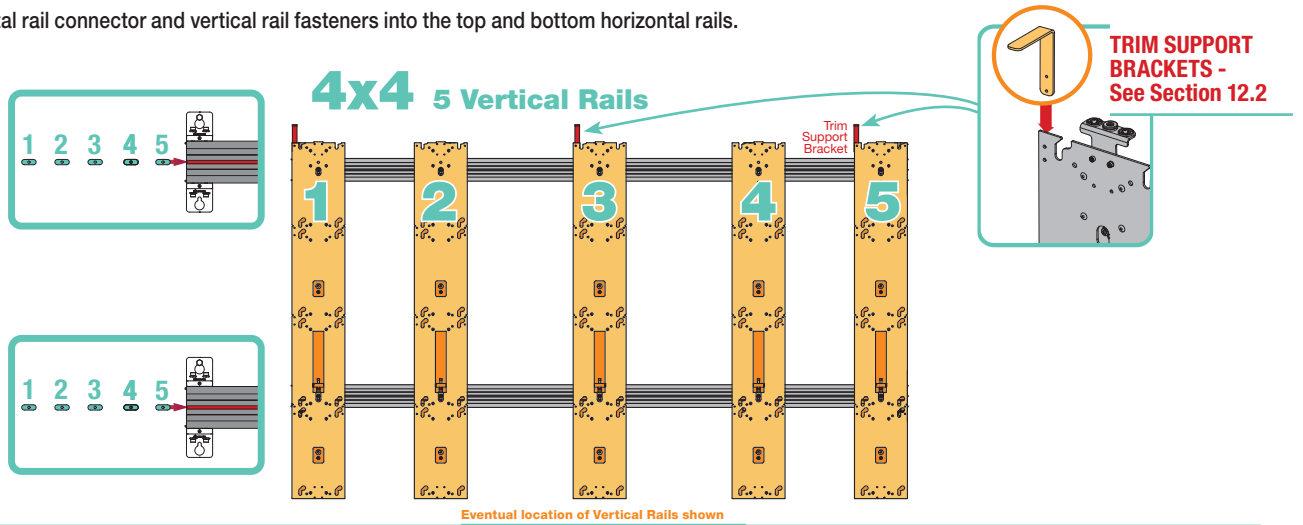

**Section 9.2 - For LED arrays 7 panels or higher - 3 Horizontal Rails**

1. Insert horizontal rail connector and vertical rail fasteners into the top, middle and bottom horizontal rails.

**TRIM SUPPORT BRACKETS - See Section 12.2**

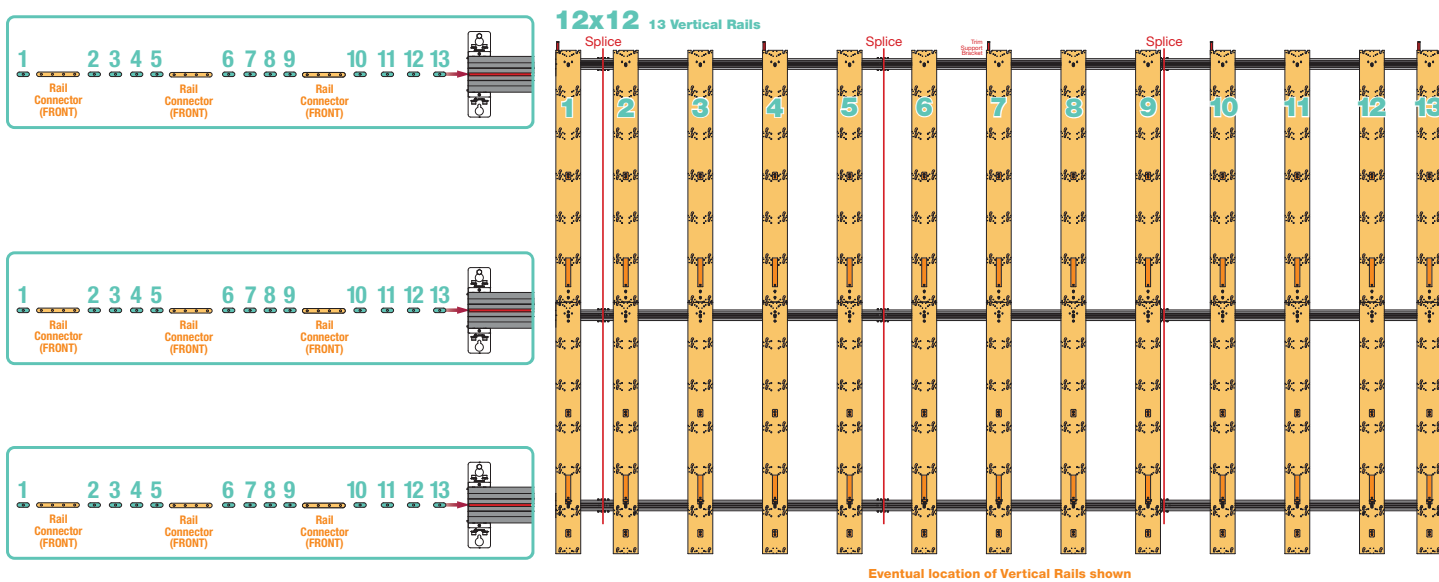
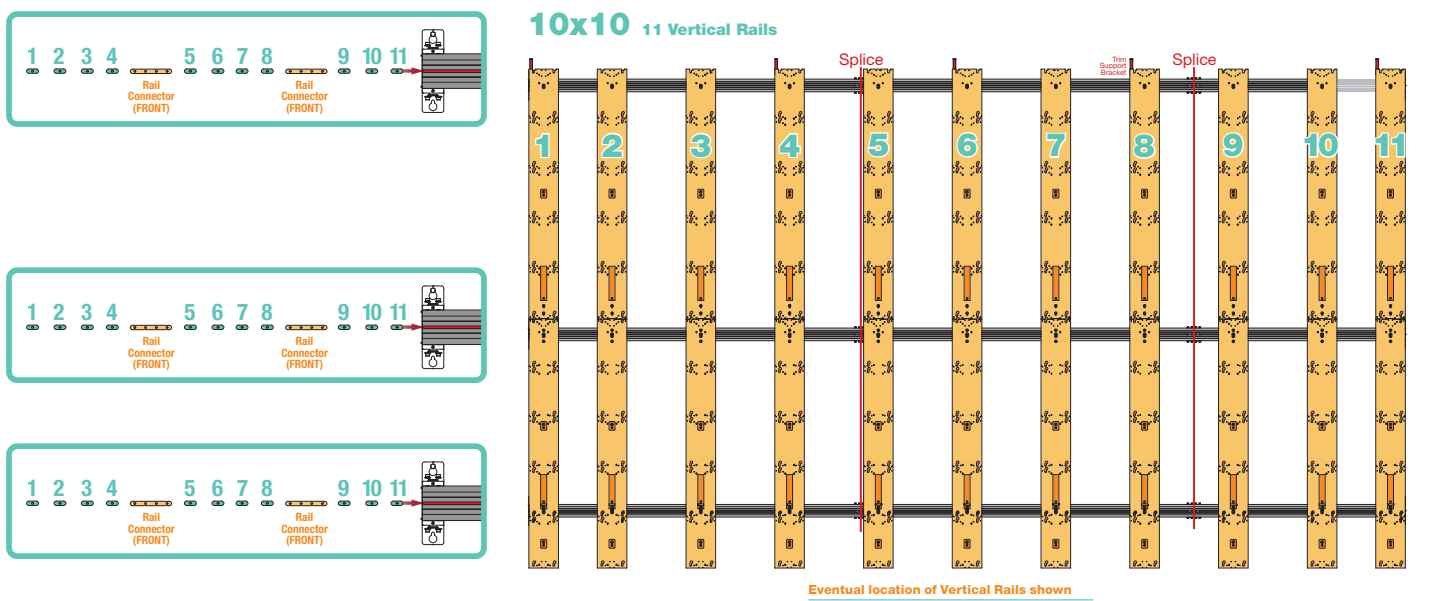
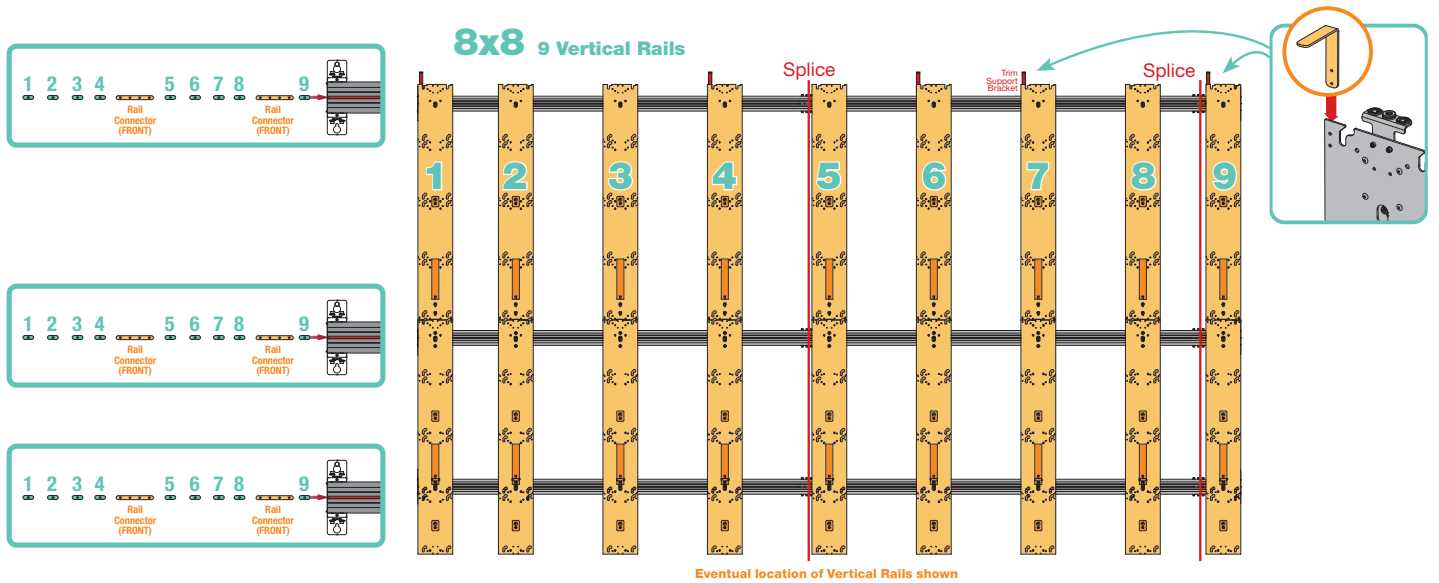



Section 10 - **Attaching Vertical Rails**

**Section 10.1 - For LED arrays up to 6 panels high - 2 Horizontal Rails**

1. Hang the Vertical Rails on the top horizontal rail and space evenly.
2. Using a 5mm hex wrench, slide the fastener nuts (from Section 9) into position and attach using the supplied M6x12 hardware.

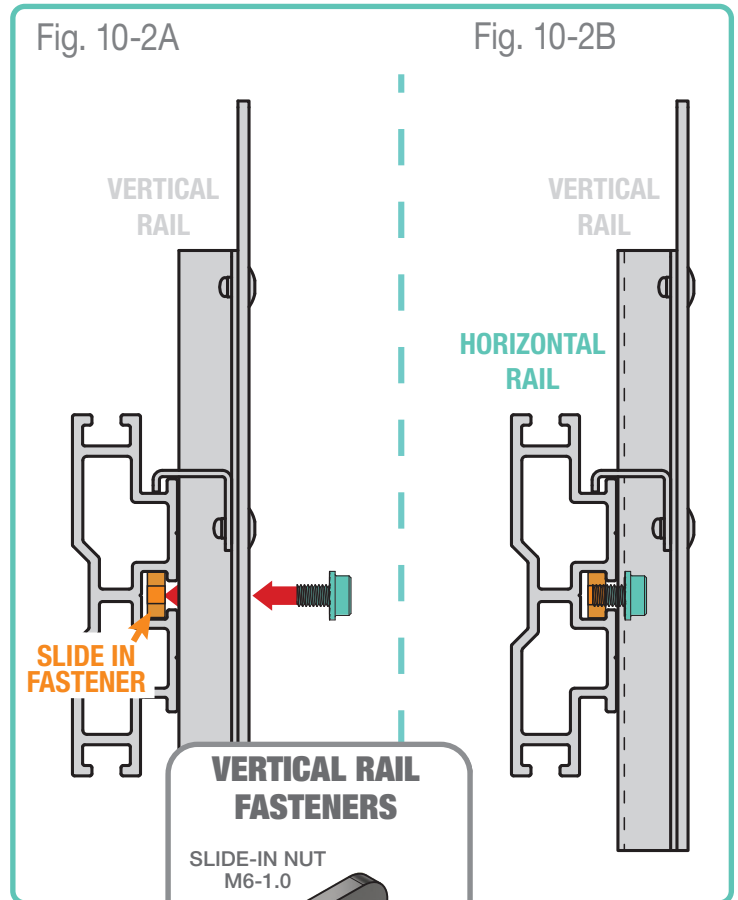
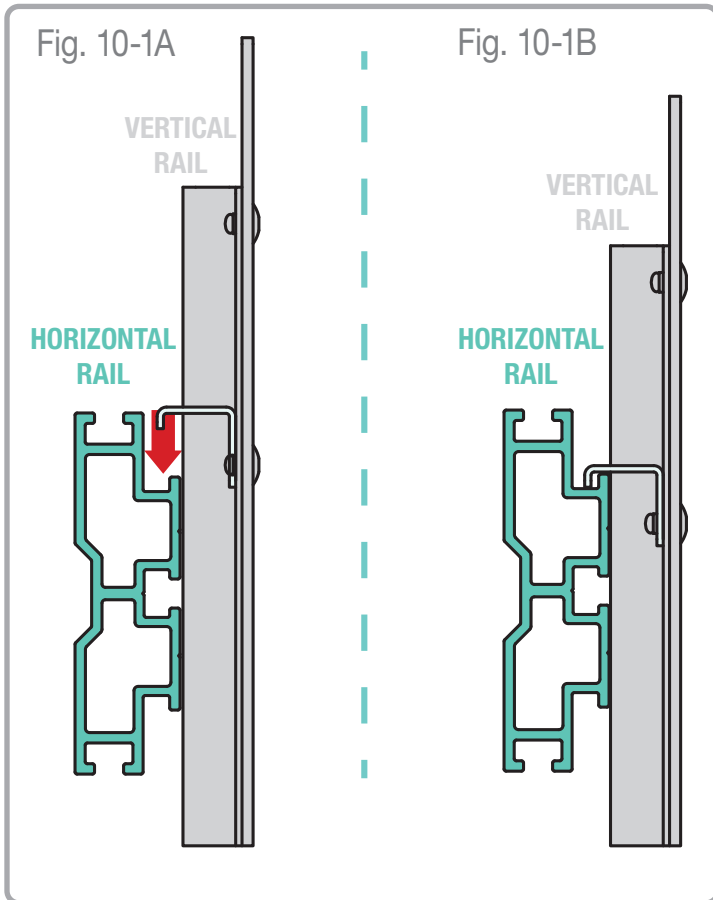
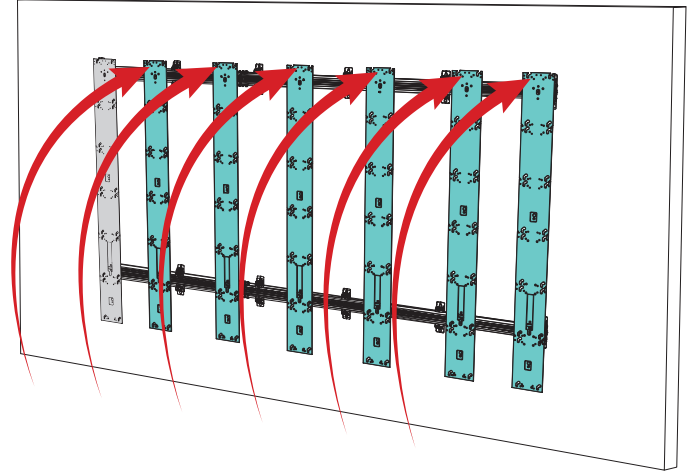
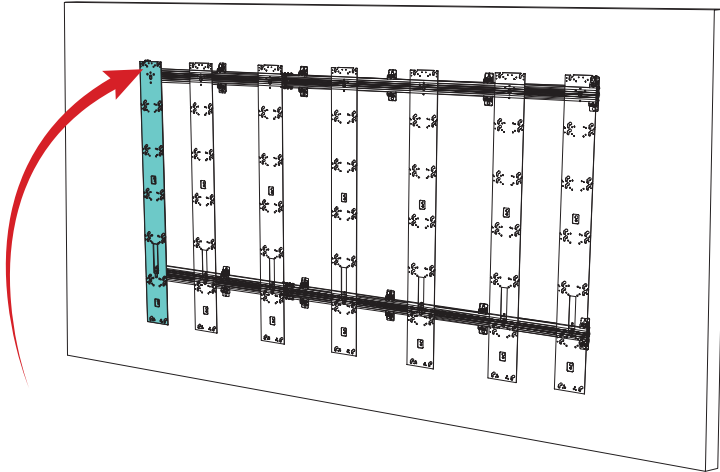

**Section 10.2 - For LED arrays 7 panels or higher - 3 Horizontal Rails**

**Section 10.2.1 - Attaching Bottom Vertical Sections**

1. Lift each Vertical Rail and position it on the middle rail.
2. Let the Vertical Rail hanger rest on the horizontal rail.
3. Slide the fastener nut from Section 8 into position and loosely attach with the provided hardware.
4. Work from left to right until all bottom **Vertical Rails** are attached.

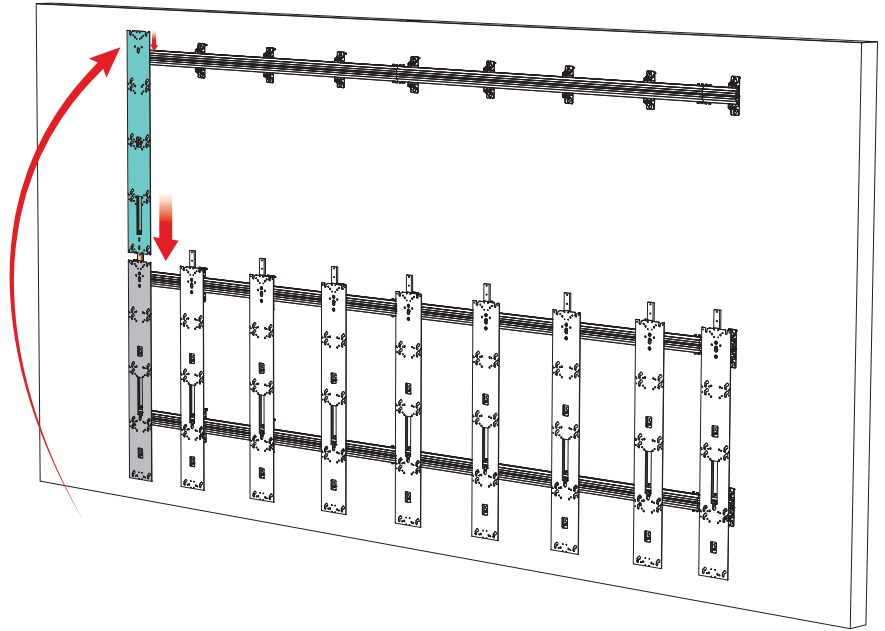

**Section 10.2.2 - Attaching Top Vertical Sections**

1. Lift each Top Section of Vertical Rail and slide it onto the connector on the bottom section.
2. Let the Vertical Rail hanger rest on the top horizontal rail and secure it loosely with provided hardware..
3. Slide the fastener nut from Section 8 into position on the bottom rail and loosely attach with the provided hardware.
4. Work from left to right until all top Vertical Rails are attached.

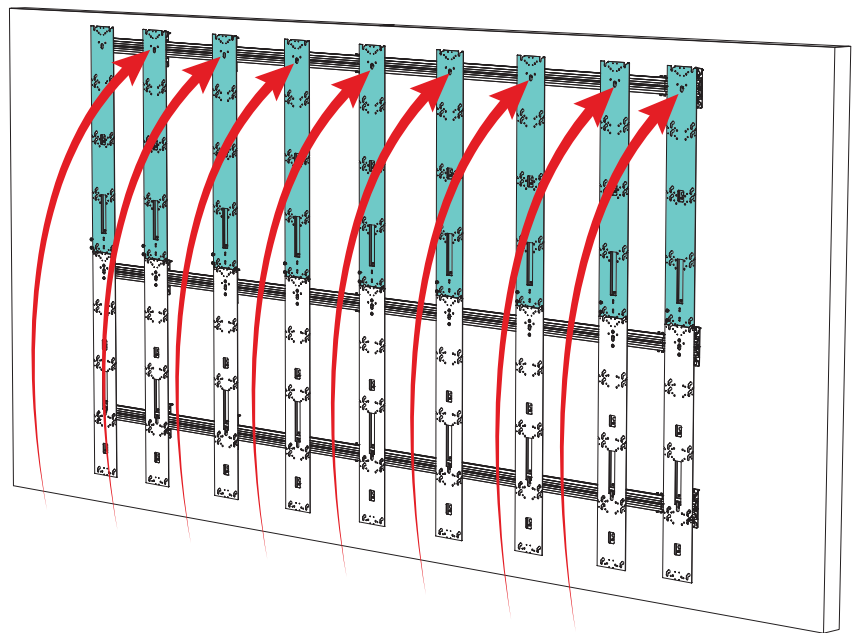
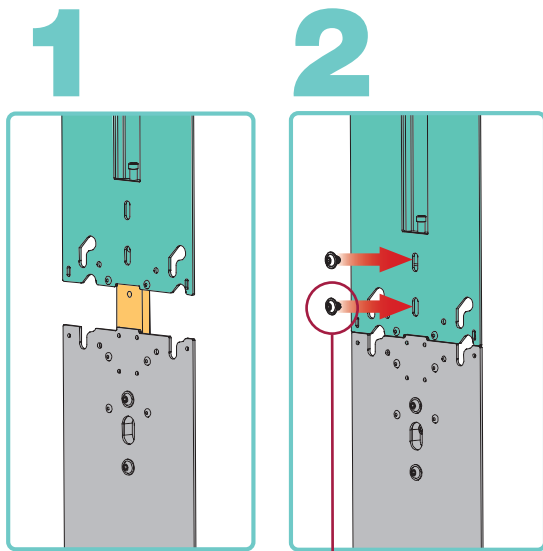



Section 11 - **Adjusting Verticals**

**Section 11.1 - Y - Axis Adjustment**

**Section 11.1.1 - For LED arrays up to 6 panels high - 2 Horizontal Rails**

1. Locate the highest Vertical Rail and shine a laser level line across utilizing the laser level notch.
2. Use a 5mm hex wrench to raise each Vertical Rail until they are all level.

**Please note:** All Vertical Rails must be aligned and level with each other.

**Section 11.1.2 - For LED arrays 7 panels or higher - 3 Horizontal Rails**

Each Vertical Rail section (upper and lower) has its own adjustment set screw.

1. Locate the highest Vertical Rail and shine a laser level line across utilizing the laser level notch.
2. Beginning with the Lower Sections, use a 5mm hex wrench to raise each Vertical Rail until they are all level.
3. Repeat Steps 1 and 2 on the Upper Sections of each Vertical Rail.

**Please note:** All Vertical Rails must be

**Adjust Vertical Rails Until Level with Laser Line**

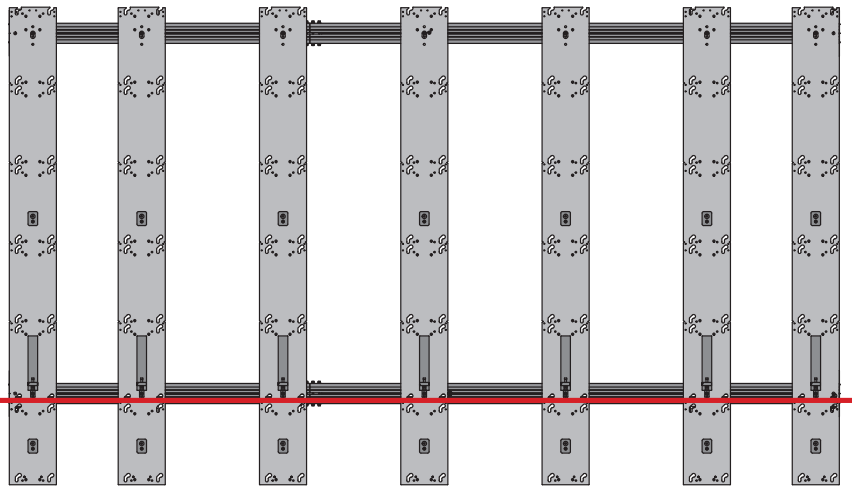

Adjust Set Screw DOWN to RAISE position of the each Vertical Rail

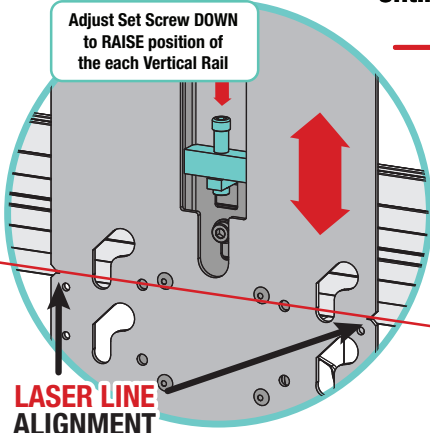

**LASER LINE ALIGNMENT NOTCHES**

**BOTTOM OF VIEWING AREA**

14 <sup>11</sup>/<sub>32</sub>"  
(364.4mm)

**Adjust Upper Vertical Rails Until Level with Laser Line**

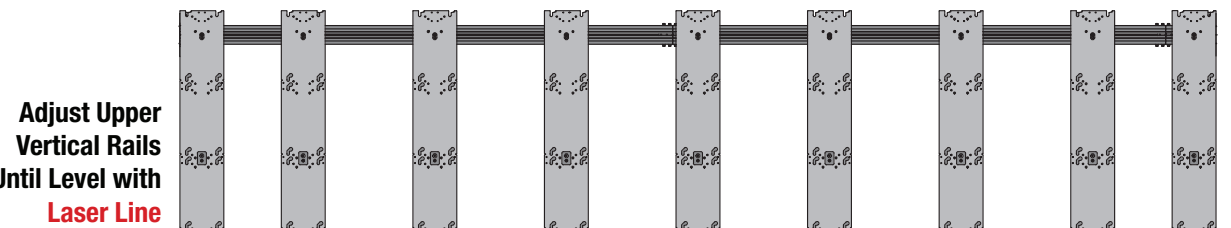

**Adjust Lower Vertical Rails Until Level with Laser Line**

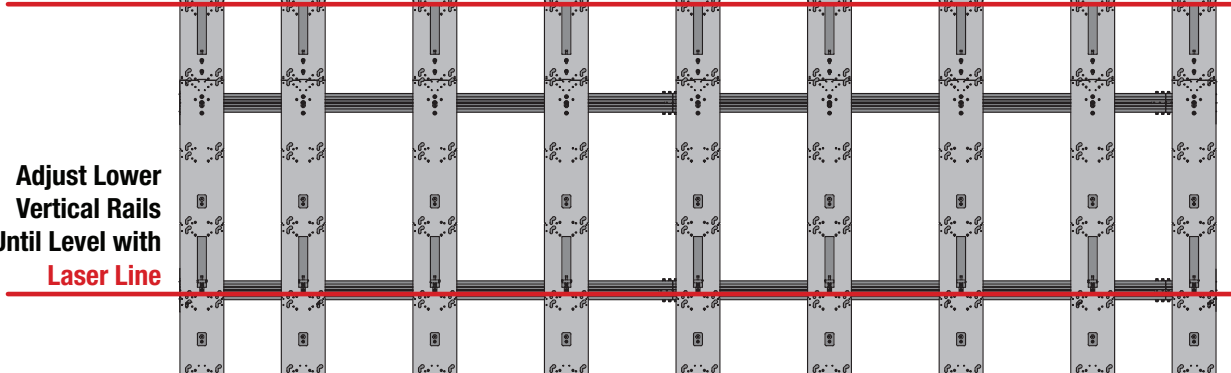

aligned and level with each other.

**Section 11.2 - X - Axis Adjustment** (Squaring Verticals with provided Alignment Tool)

**Section 11.2.1 - For LED arrays up to 6 panels high - 2 Horizontal Rails**

**Adjust Vertical Rails Until Plum with Laser Line**

1. Shine a laser line at the left edge of the structure and check that the first Vertical Rail is square with the floor. To adjust, loosen the fasteners installed in Section 10, Step 3 and slide the Vertical Rail along the Horizontal Rail until. Tighten fasteners when the first vertical is square.
2. Attach the two (2) alignment tools to the vertical rail positioned in step 1.  
  
Using Side A of the alignment tool insert the pins into the corresponding alignment holes on the first vertical rail at the top and bottom locations.
3. Adjust the position of the next vertical rail in order for the alignment pin on each tool to align with the corresponding alignment hole in the vertical rail.
4. Tighten the second vertical rail mounting screws.

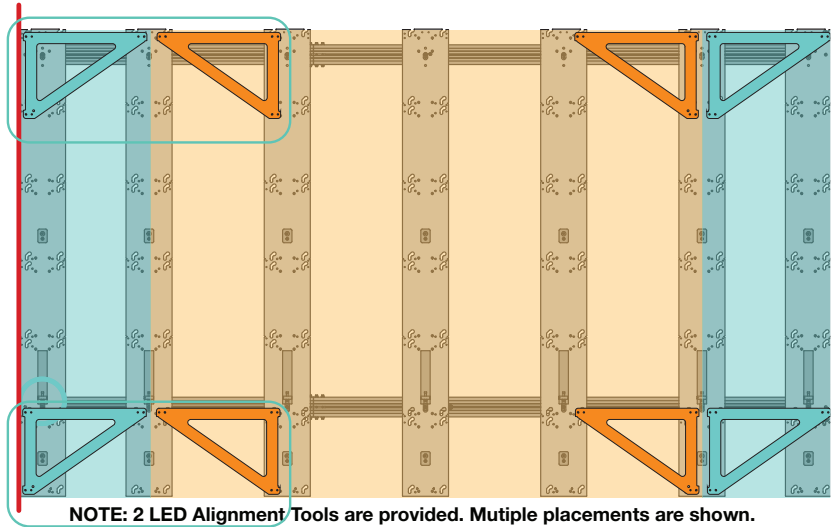

NOTE: 2 LED Alignment Tools are provided. Multiple placements are shown.

Note: Use Side A of the alignment tool for the last vertical rail alignment procedure.

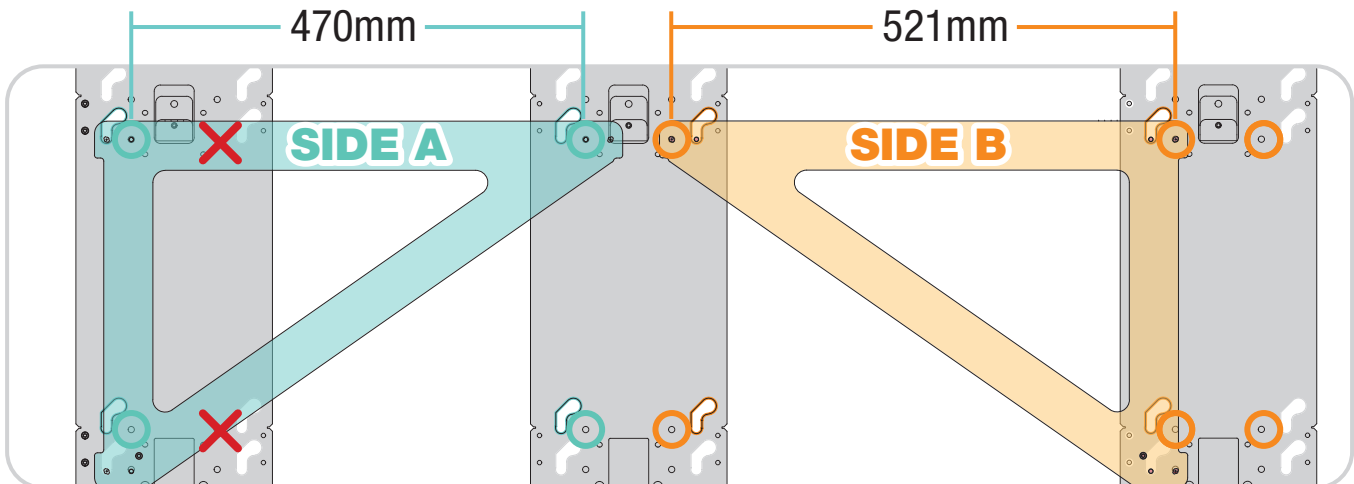
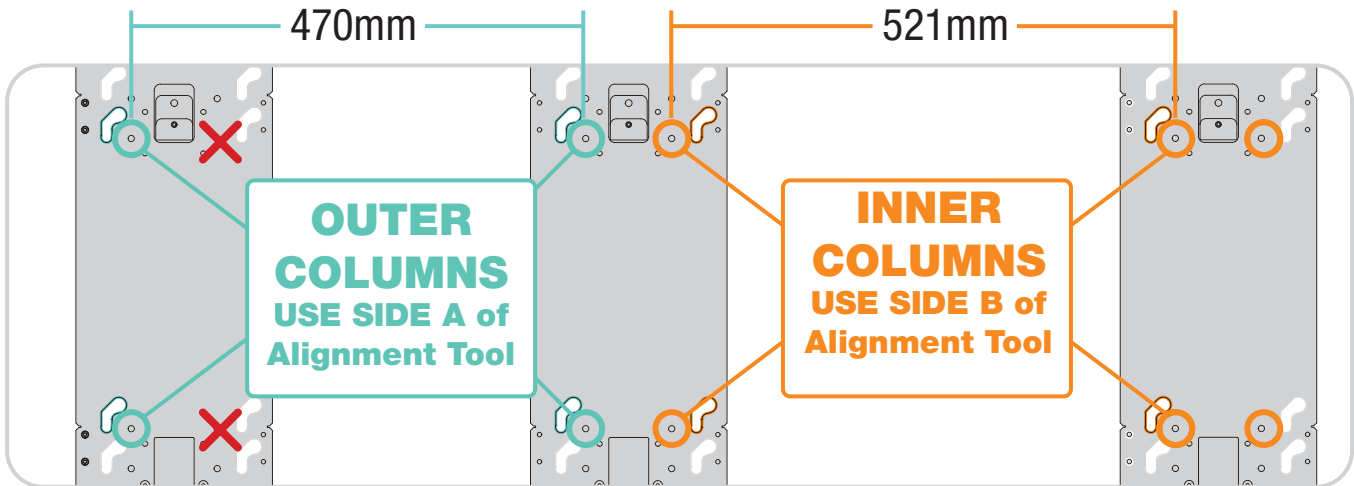



**Section 11.2.2 - For LED arrays 7 panels or higher - 3 Horizontal Rails**

1. Shine a laser line at the left edge of the structure and check that the first Vertical Rail is square with the floor. To adjust, loosen the fasteners installed in Section 10, Step 3 and slide the Vertical Rail along the Horizontal Rail until. Tighten fasteners when the first vertical is square.
2. Attach the 2 alignment tools to the vertical rail positioned in step 1. Using Side A of the alignment tool insert the pins into the corresponding alignment holes on the first vertical rail at the top and bottom locations.
3. Adjust the position of the next vertical rail in order for the alignment pin on each tool to align with the corresponding alignment hole in the vertical rail.
4. Tighten the second vertical rail mounting screws.
5. Remove alignment tools and re-attach each using side B to the 3rd vertical rail using the corresponding alignment holes at the top and bottom of the rail.
6. Adjust the position of the 3rd vertical rail so that the pin on the end of the tool aligns with the corresponding hole on the 2nd vertical rail.
7. Tighten the mounting screws on the 3rd mounting rail and repeat the process moving across the structure from left to right.

**Adjust Vertical Rails Until Plum with Laser Line**

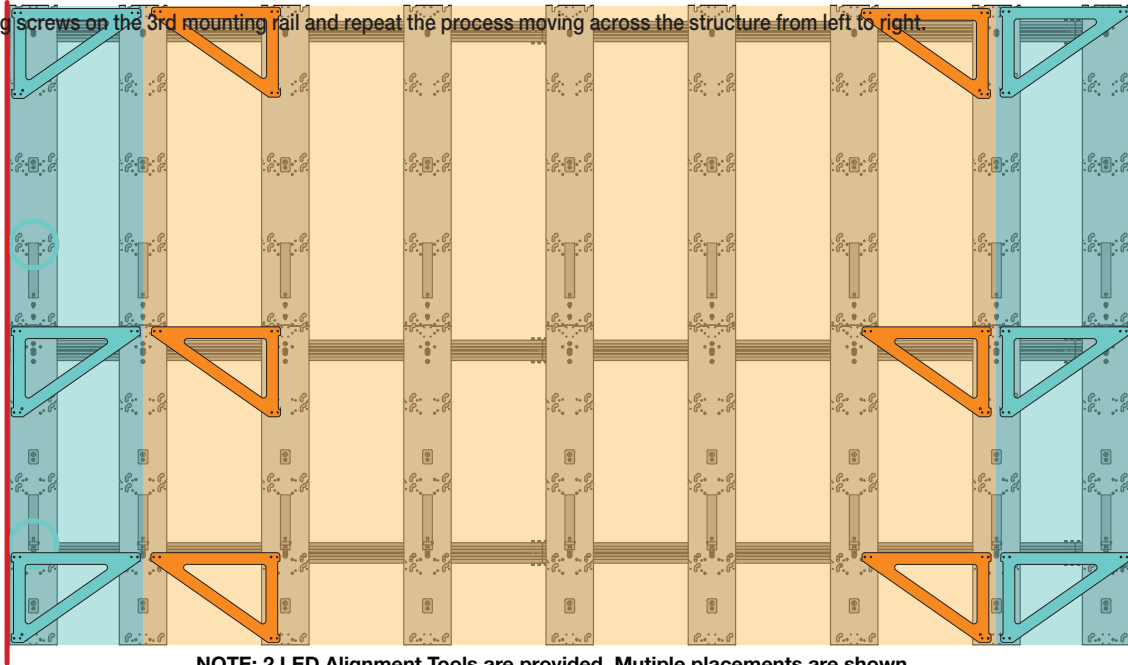

**NOTE: 2 LED Alignment Tools are provided. Multiple placements are shown.**

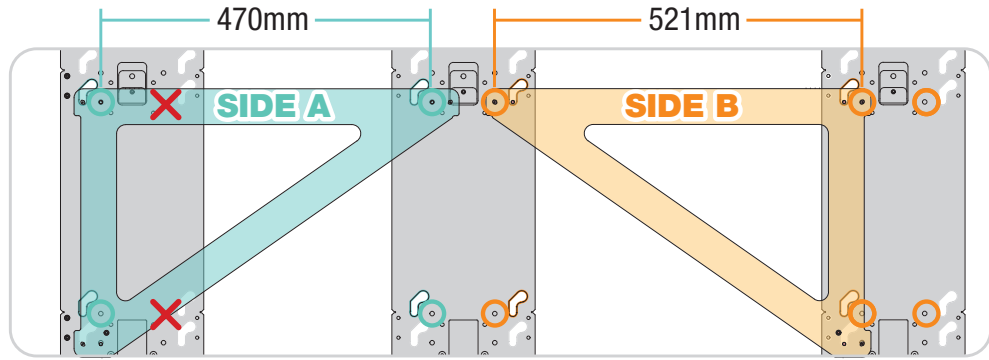
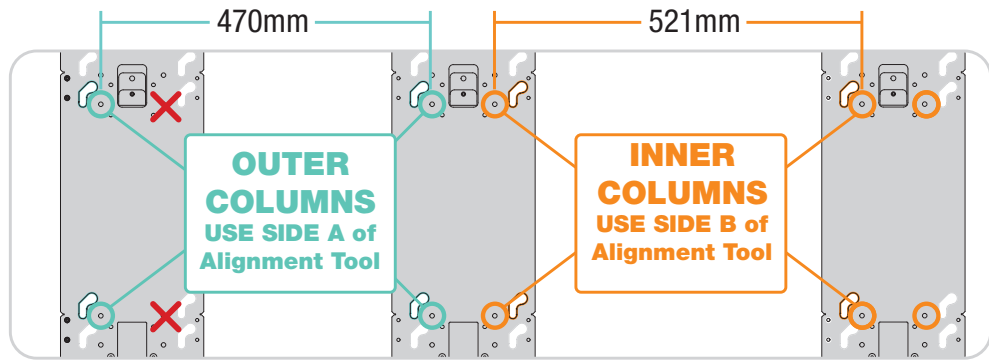

**Section 11.3 - Z - Axis Adjustment**

1. Using a 3mm hex wrench, adjust each Wall Adjuster Bracket until it contacts the wall.
2. Use the clearance hole in the vertical rail to allow for a socket to drive a lag screw (by others) into the wall.
3. Rotate the differential screw to push or pull the vertical rail to be straighter if required.

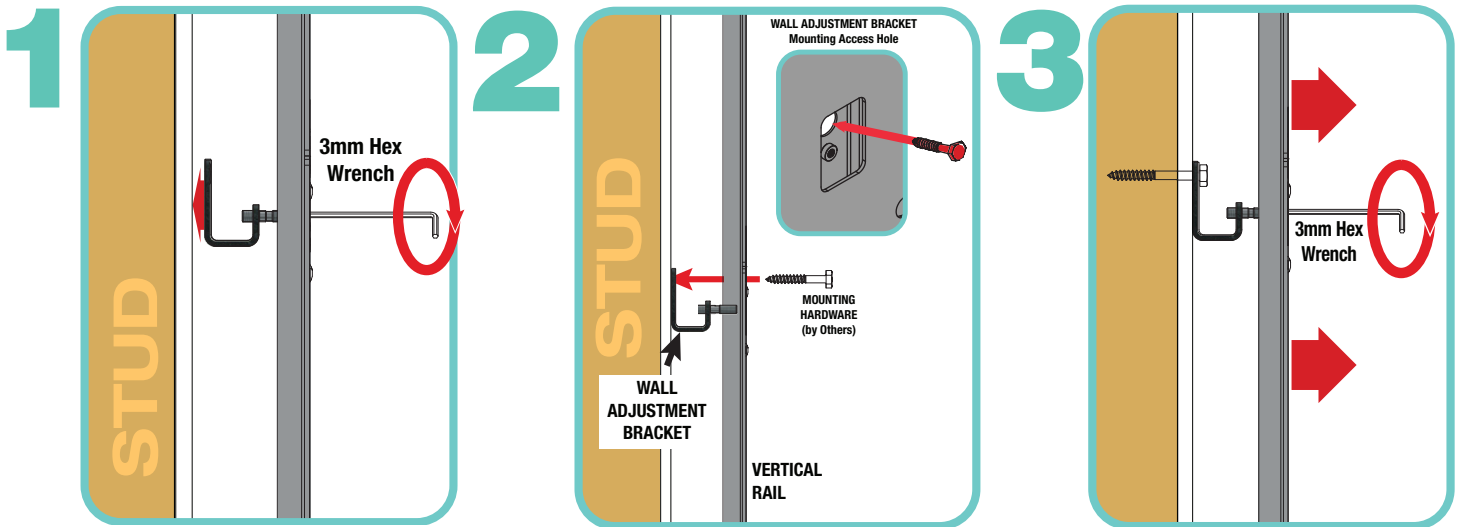

**Adjust Wall Adjustment Brackets Until All Vertical Rails are flush.**  
**Bubble Level recommended.**

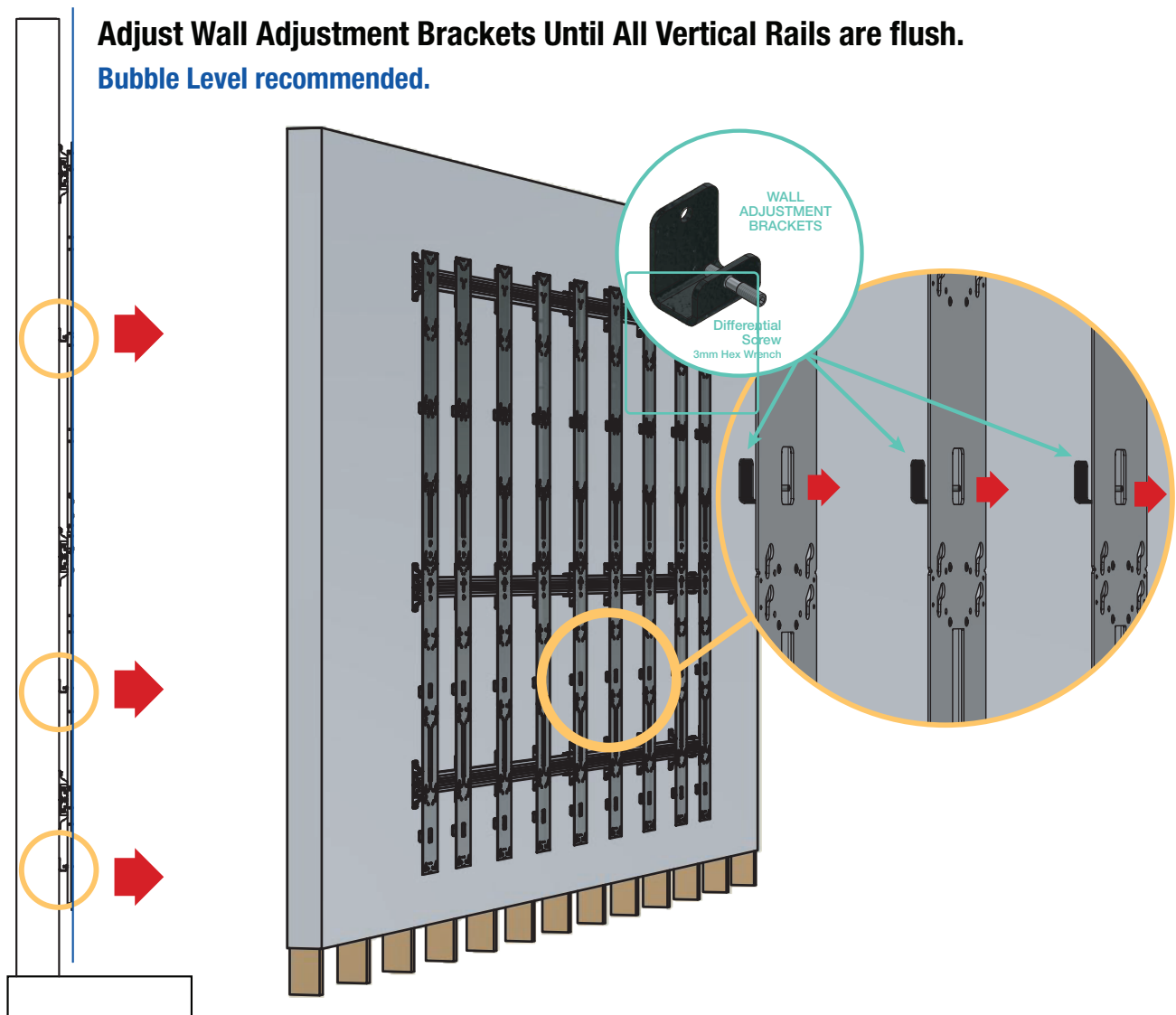

Section 12 - **Attaching Trim Brackets**

**Section 12.1 - Installing TOP Trim Brackets**

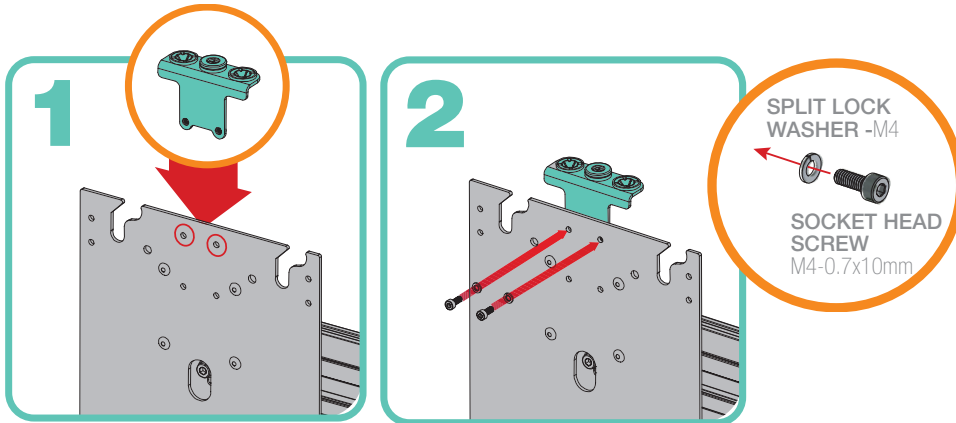

**Section 12.2 - Installing TOP Trim Support Brackets**

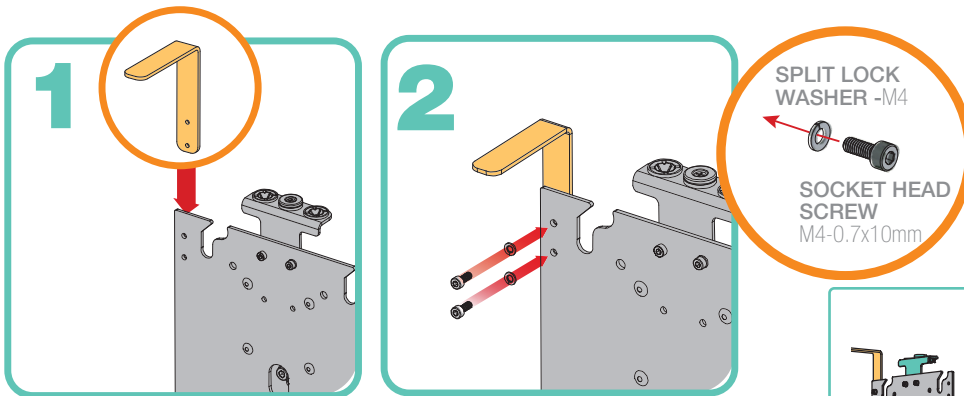

Trim Support Bracket Locations will vary depending on array size.  
**Refer to Section 9**

**Section 12.3 - Installing Side Trim Brackets**

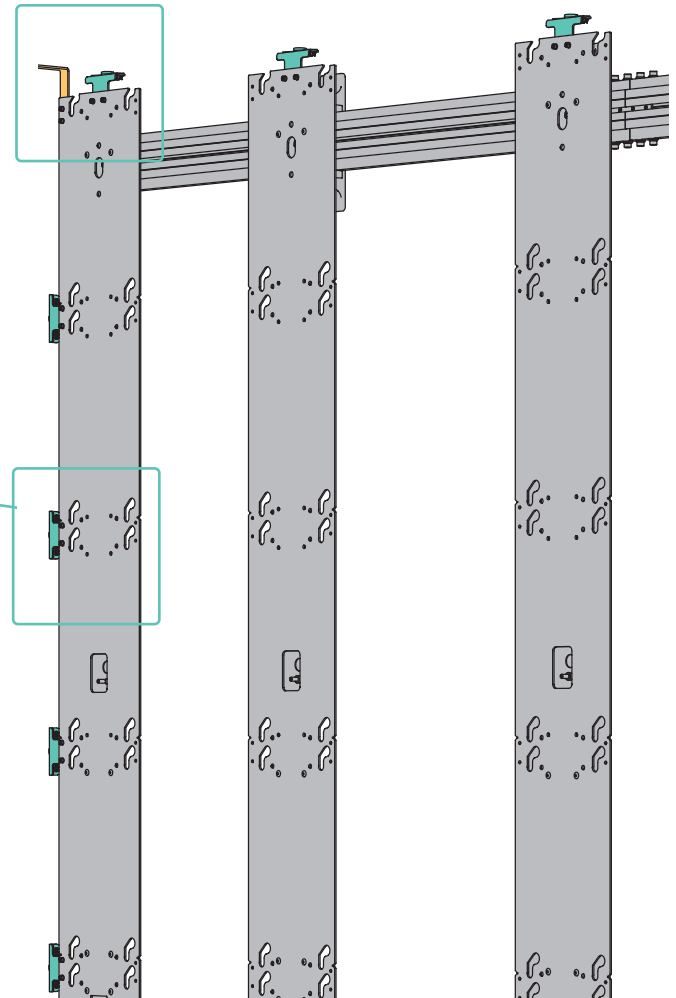
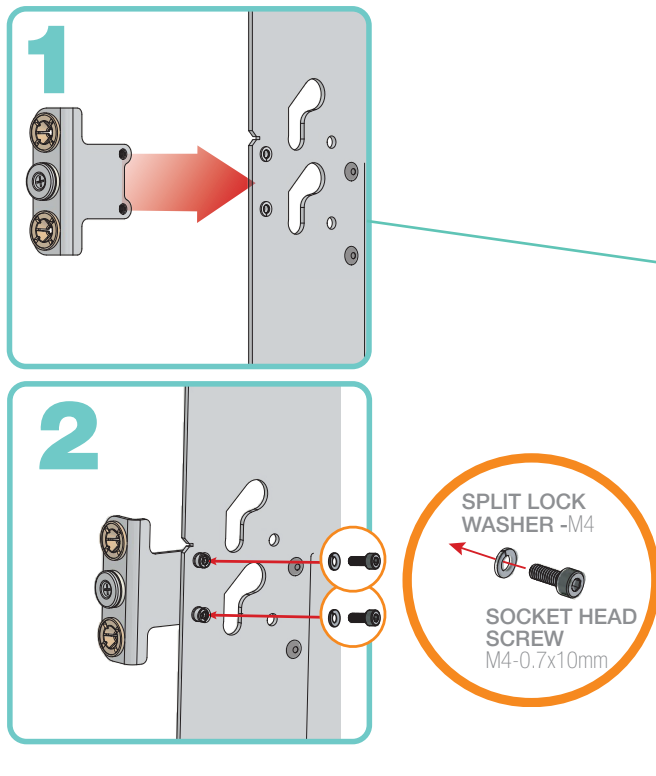

**Section 12.4 - Installing Bottom Trim brackets**

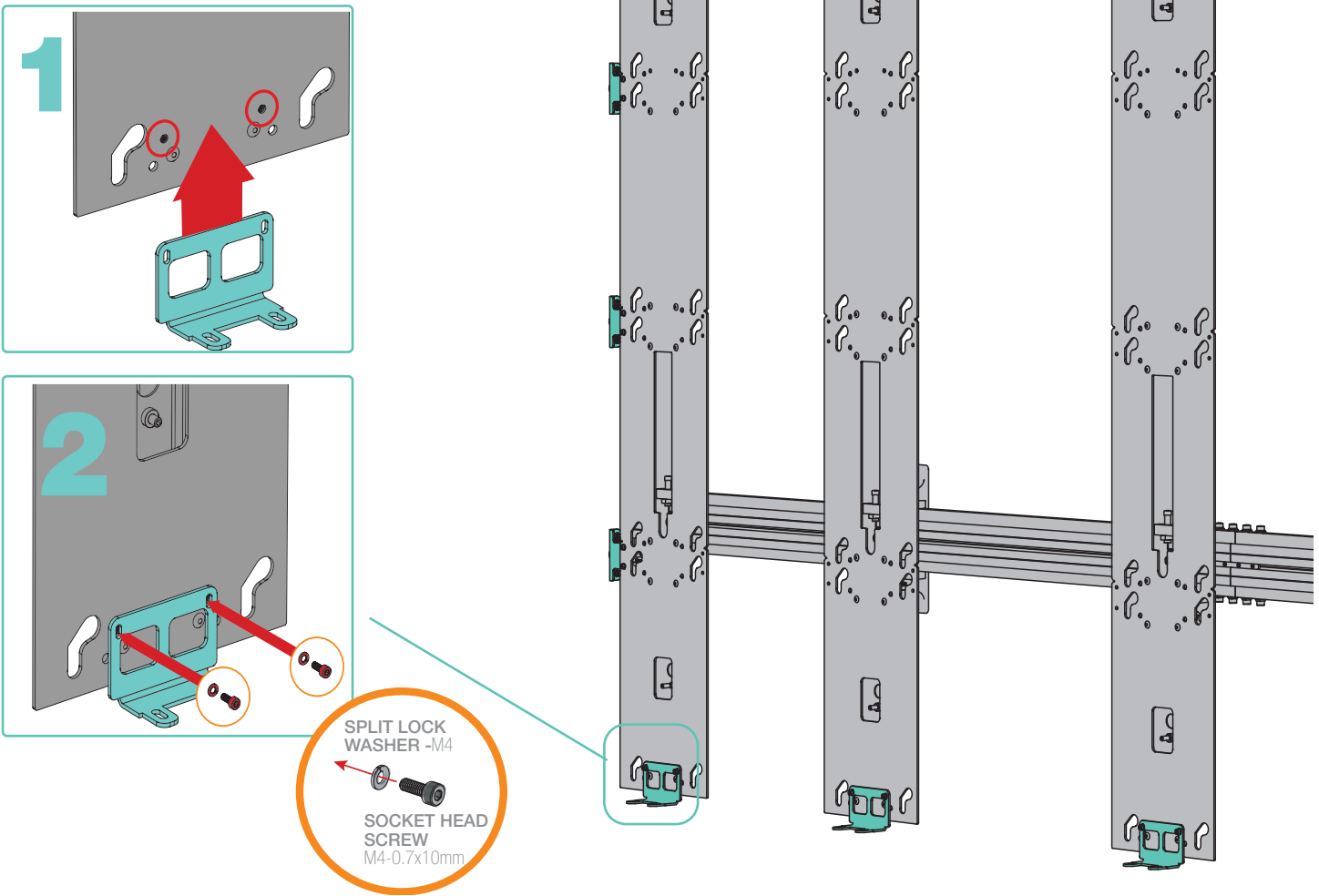

Section 13 - **Installing Bottom Trim** (must be done prior to LED Installation)

**Section 13.1 - Installing BOTTOM Trim Sections**

**BOTTOM TRIM**

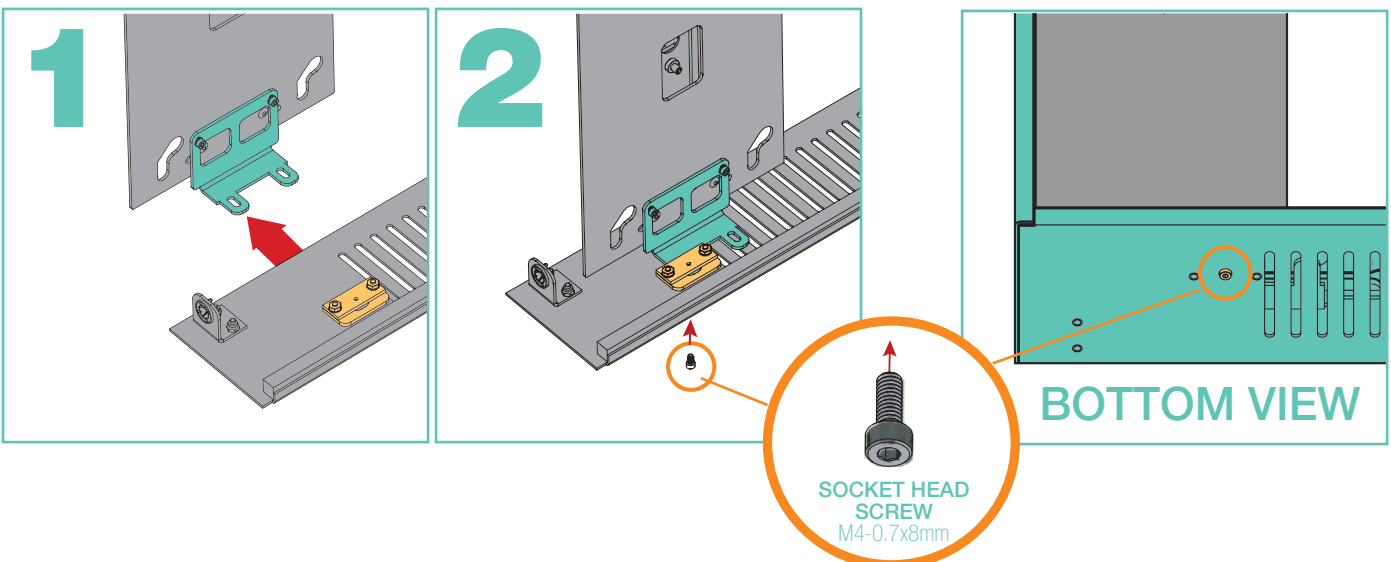

Section 14 - **Attaching LED Panels LED Cabinets**

**NOTE: All trim brackets and the Bottom Trim Panels MUST be installed (Section 13) before installing LED CABINETS**

**Section 14.1 - Attaching Spring-Loaded Fasteners**

1. Replace the mounting bolts (pre-installed by LED manufacturer) in the LED cabinet with the provided Spring Loaded mounting studs.

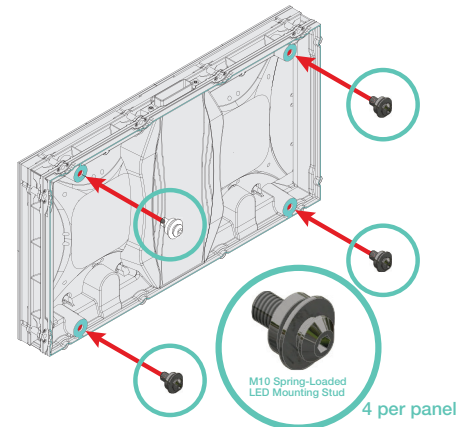

**Section 14.2 - Attaching LED Panels**

1. Starting in the bottom left corner, insert the four (4) Spring-Loaded Mounting studs into the angled slots on the vertical rail as shown. The head of the studs will engage with the back side of the vertical rail and the spring washer will remain on the front face (does not fit through the slot). Once the head of all 4 studs are fully inserted, lower the panel into the final location.

**LED PANEL PLACEMENT OUTER COLUMNS**  
(Left & Right Sides)

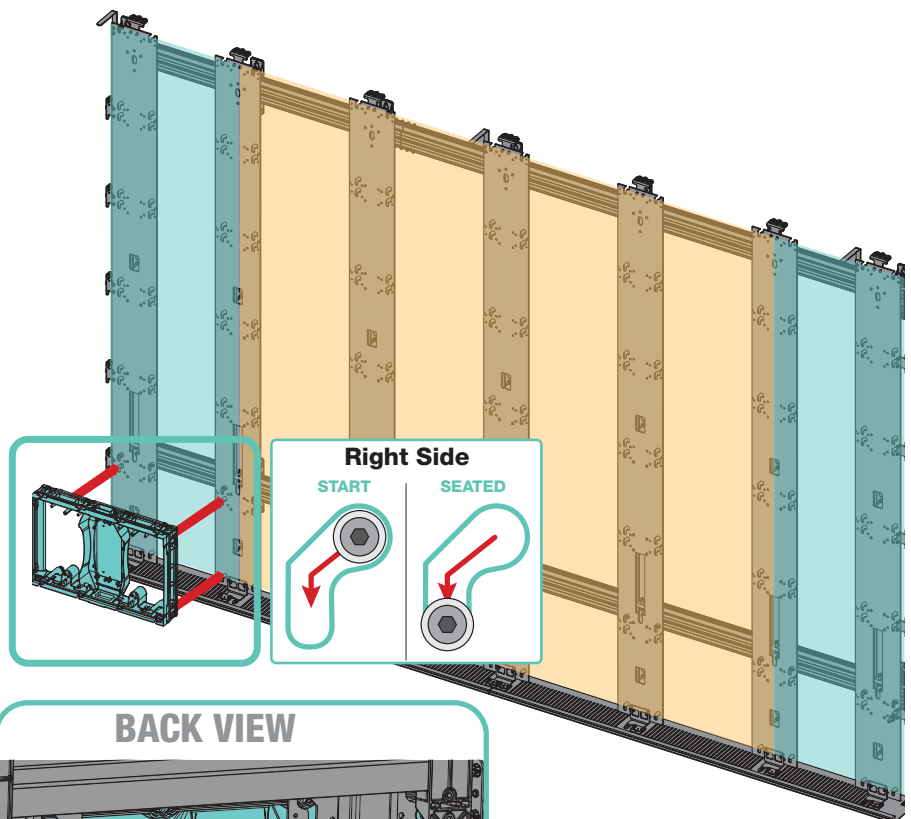
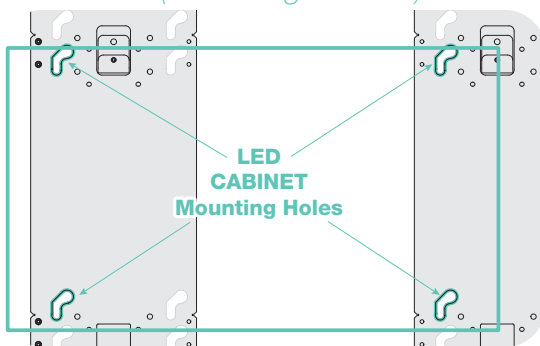

**NOTE:** All 4 mounting studs must be fully seated at the bottom of the slot.

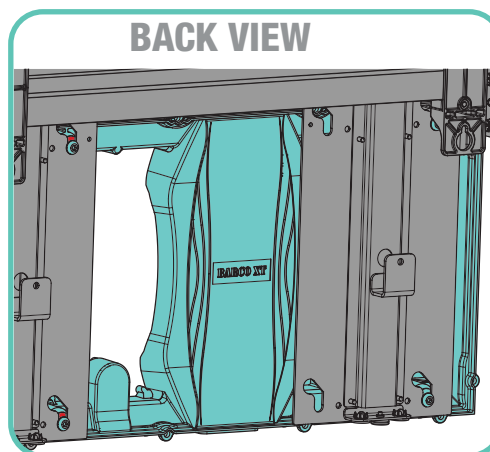
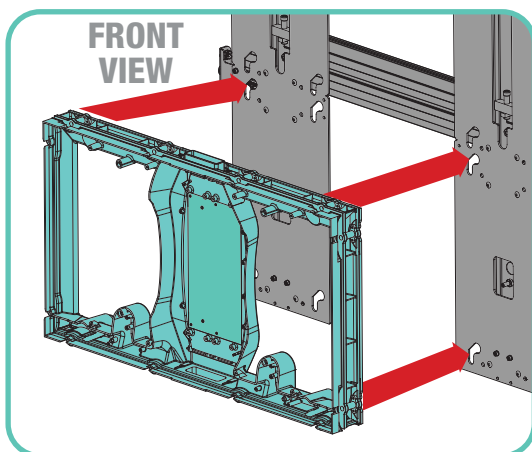

2. Attach the next LED cabinet direct to the right of the first. Continue until the first row is complete.
3. Working from left to right, attach the row of LED cabinets.
4. Continue until all LED cabinets are installed.

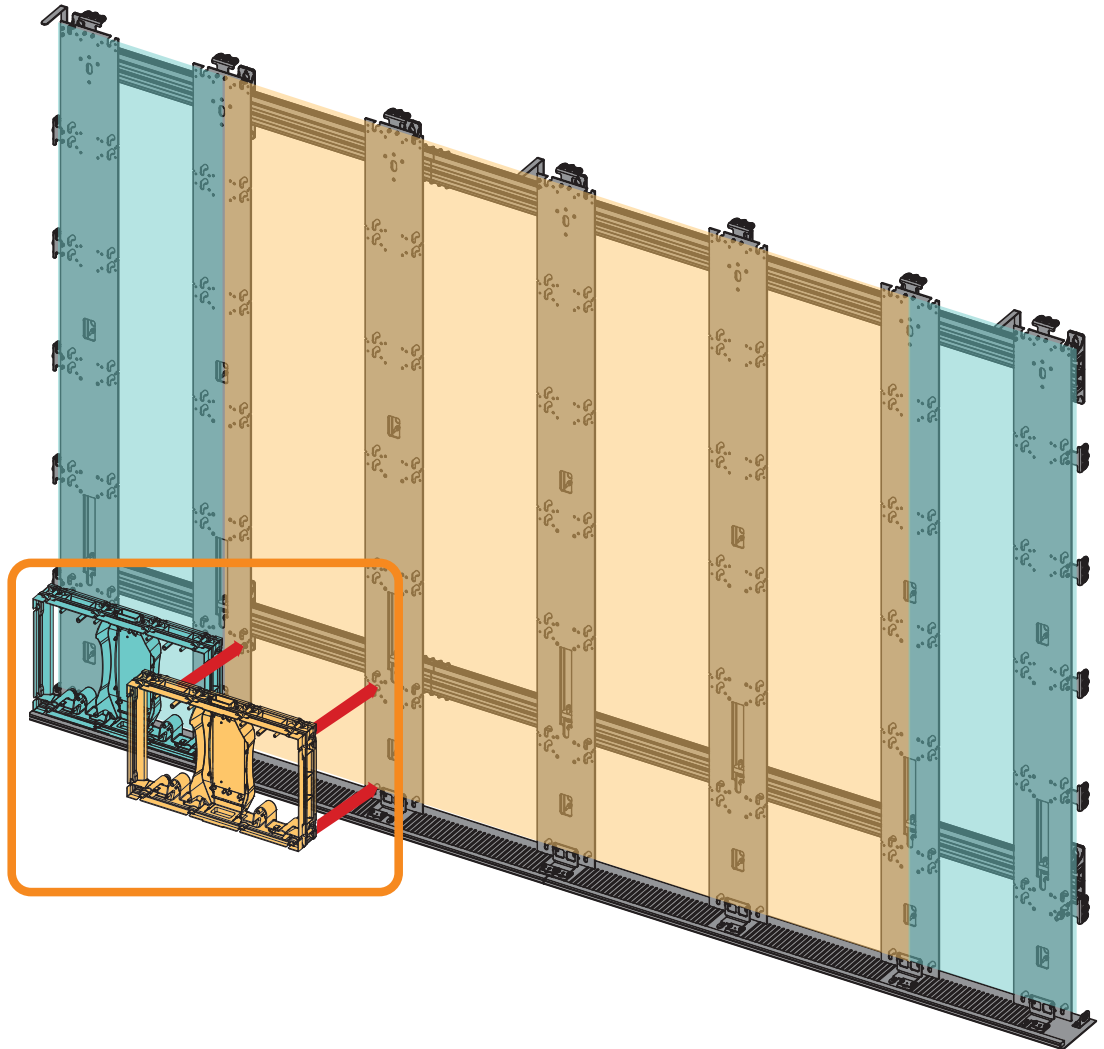

**LED PANEL PLACEMENT  
INNER COLUMNS**

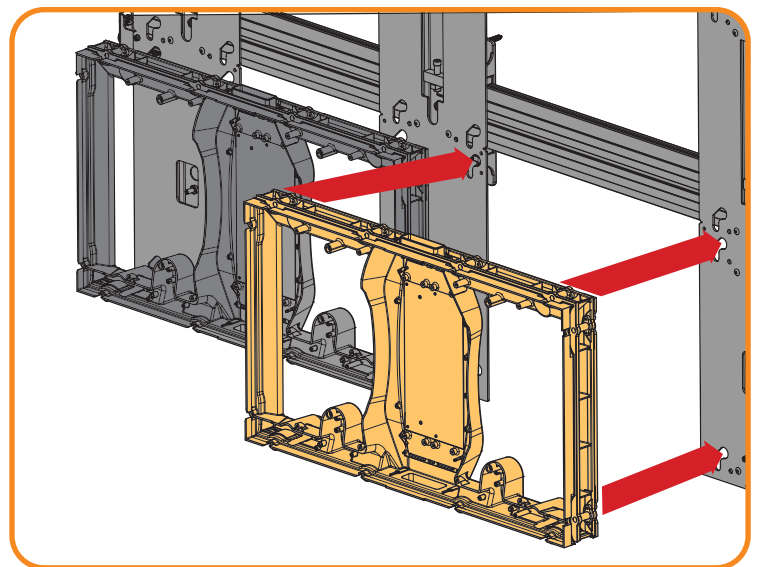
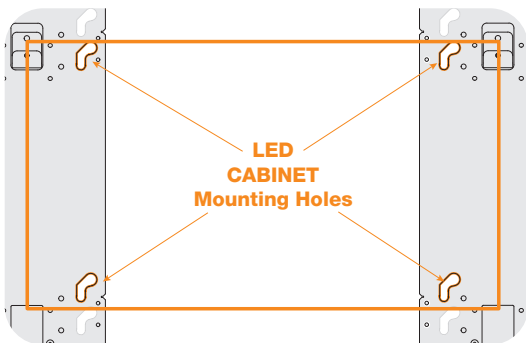

Section 15 - Attaching Trim to Trim Brackets

TOP TRIM

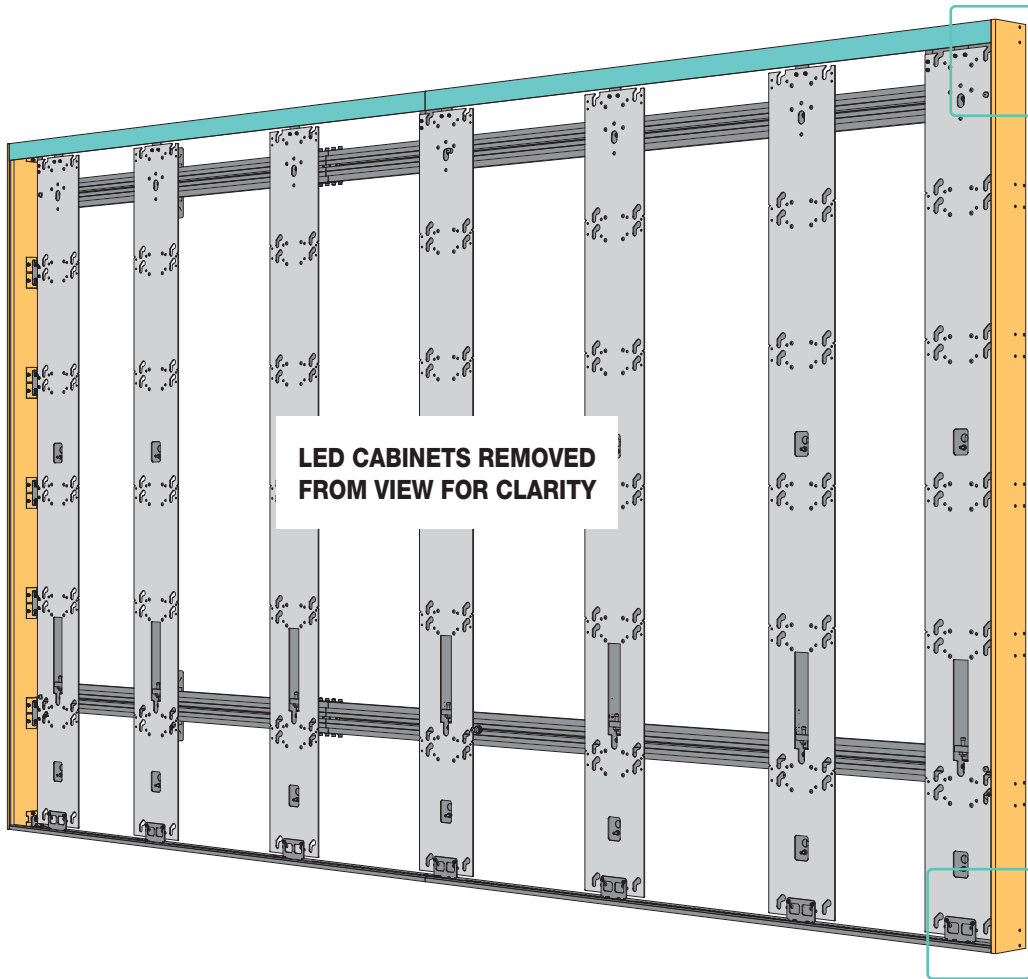
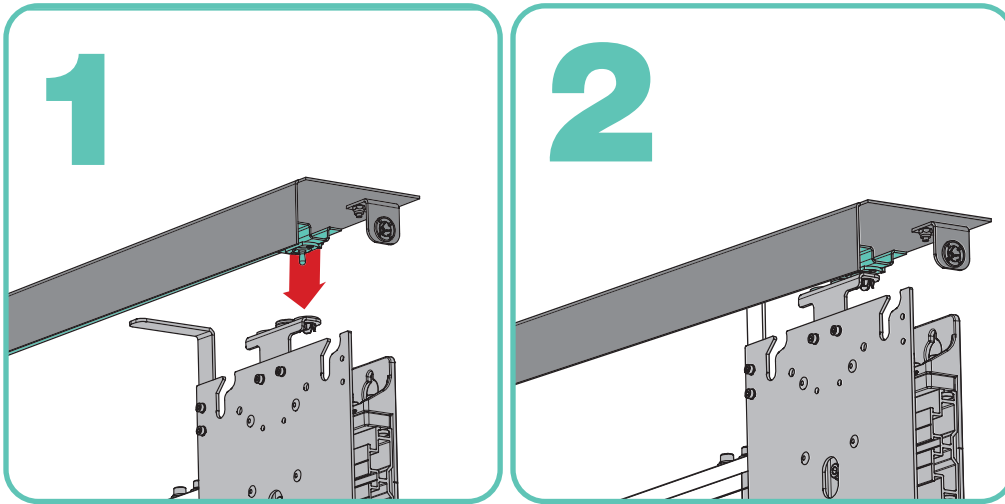

SIDE TRIM

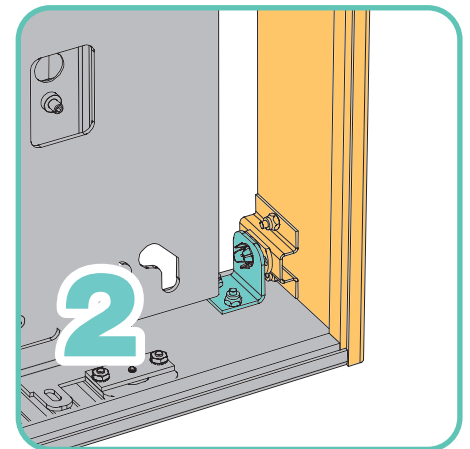
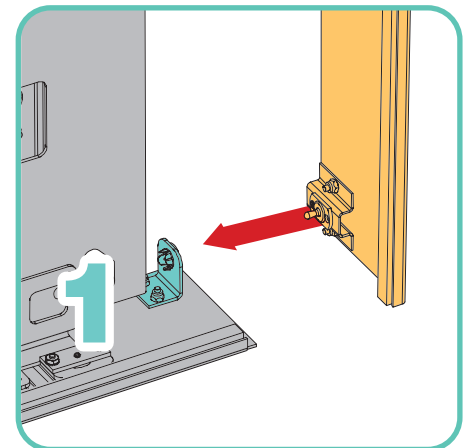

 DRAPER®

# FOUNDATION™

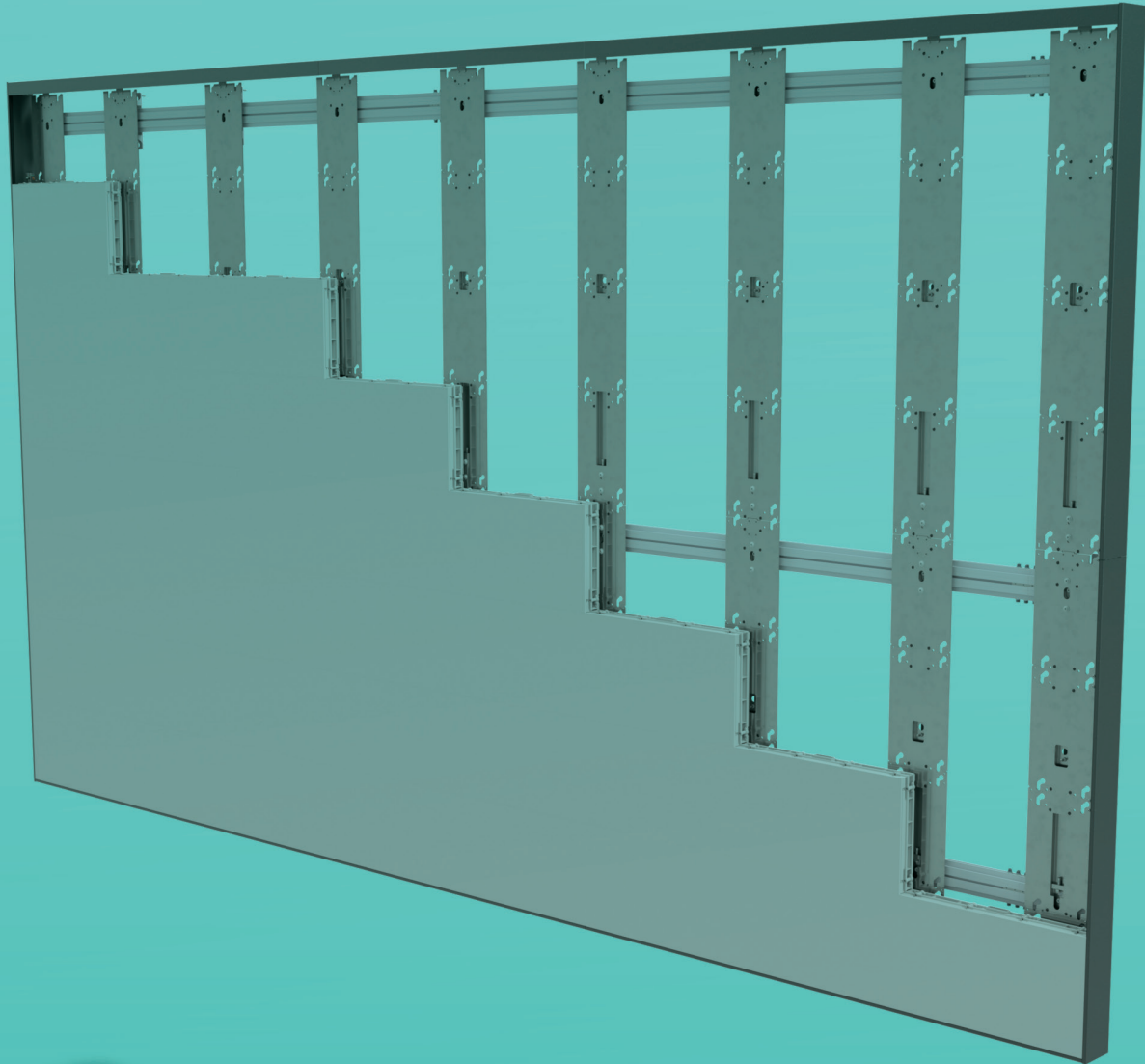

for

**BARCO**

**XT Series**