

Overview

3 x 3 Draper Mount Interface for Barco UniSee®

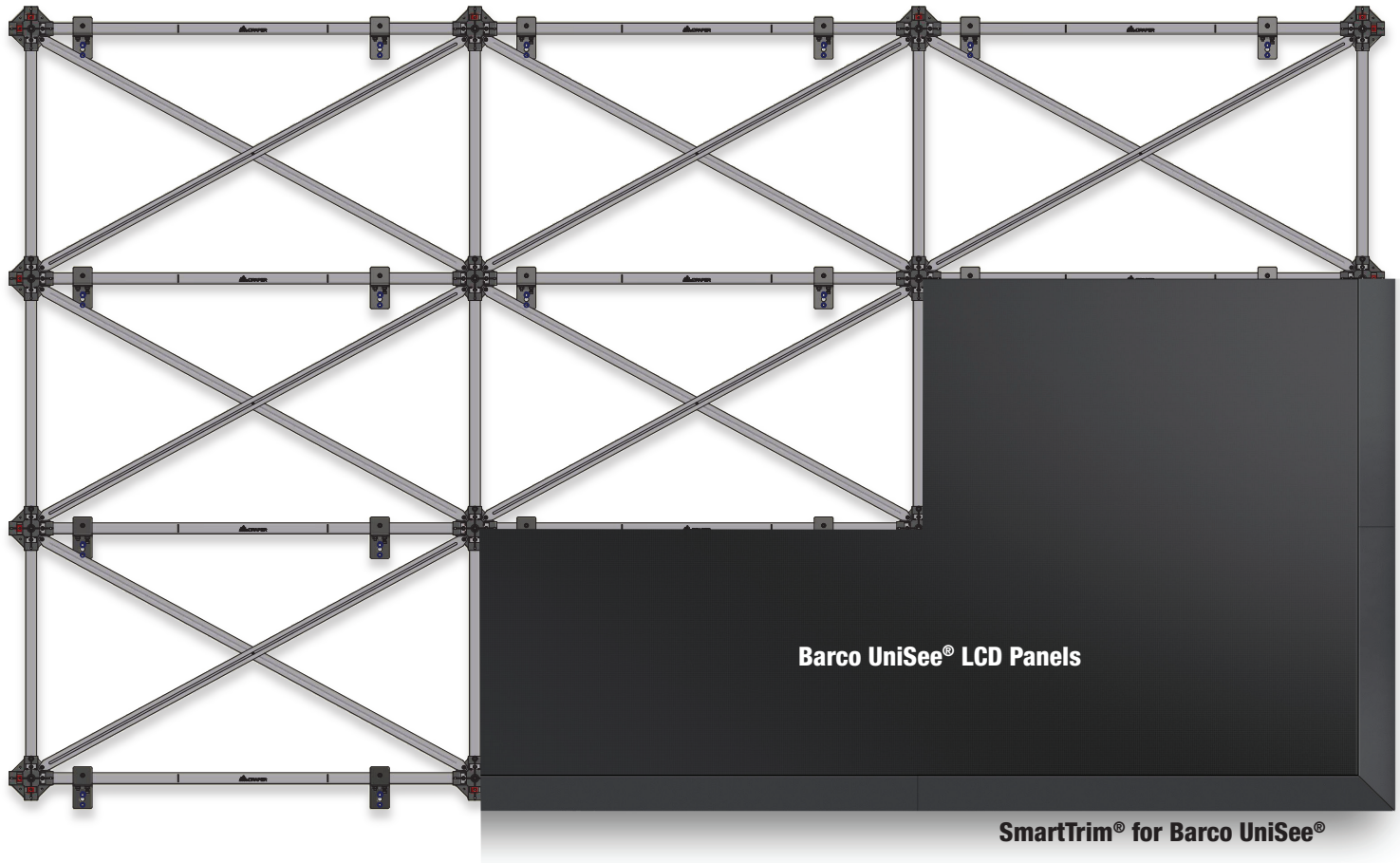

Section 1 - Personnel and Tools Required

**PERSONNEL REQUIRED**

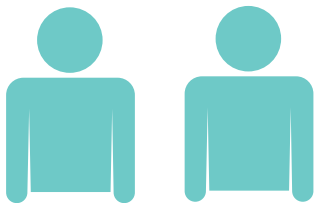

Barco UniSee Service Tool



No. 5 HEX WRENCH



10mm, 15mm & 17mm WRENCHES

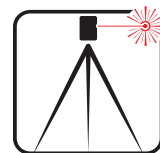

LASER LEVEL

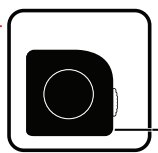

TAPE MEASURE



POWER DRILL

If you have any difficulties installing or servicing your LCD wall, call your dealer or Draper, Inc.

## Important Safety Information



**Improper installation and use of LCD Wall can result in serious injury or death. Primarily, injuries can occur when the LCD Wall falls due to imprecise installation, mishandling of the LCD Wall during installation or installation on an insufficient wall or ceiling structure. Please use extreme care.**

1. Please read the following installation guidelines thoroughly and follow them carefully. Failure to do so may cause product to fall or otherwise fail, and could result in serious injury.
2. Installation and calibration of the LCD Wall should only be performed by an authorized, qualified, and experienced professional. In particular, electrical work and wiring [indicated in diagram by dashed lines] must be completed only by a qualified professional electrician who has read this manual completely and is familiar with the construction and operation of this equipment and the hazards involved.
3. Turn off power and any nearby equipment or cables carrying electricity before connecting switches, wires, controls, or electrical components.
4. Do not affix the unit to wall or ceilings that have inadequate strength to permanently hold the unit during use. It is the owner's and installer's responsibility to confirm the wall to which the unit attaches is sufficient to permanently hold the weight and stress loads of the unit at all times. Draper, Inc., is not responsible for improper installation, application, testing or workmanship related to the product at place of installation.
5. It is the installer's responsibility to make sure appropriate fasteners are used for mounting.
6. All brackets and other hardware must be installed level. LCD Wall must be level and square.
7. Never leave the area while operating the LCD Wall during installation, maintenance, or normal operation, unless it is secure and safe.
8. Before testing or operation, carefully inspect the entire area and areas underneath to be sure no persons or objects are in the area.
9. During testing or operation, carefully watch the surrounding area for any potential safety concerns including nearby persons or objects.
10. After installation, the entire system should be carefully tested to ensure safe and normal operation. Extreme care should be taken during testing to remain clear of moving parts to avoid possible injury.
11. Operation of LCD Wall should be performed only by authorized and qualified personnel, who have been trained in the safe and effective operation of the LCD Wall & understand its safety features.
12. The safety features of the LCD Wall should never be disabled, bypassed or overridden. The system should not be operated until all safety features are properly and completely installed, calibrated and tested.
13. LCD Wall may need to comply with local, state or district rules and regulations, in particular when installed in schools. All applicable rules and regulations should be reviewed before installation and use.
14. Failure to precisely follow installation guidelines invalidates all warranties.
15. Custom products/installations may not be reflected in this manual. Call Draper, Inc., if you have questions about the installation of custom products or any questions about your installation.

## Before Beginning Installation

1. Look for any job site conditions that could interfere with installation or operation of the system.
2. Read carefully and be sure to understand all installation instructions and all related operations manuals. These instructions are intended to as a guide for the installer and owner. They should be followed closely and combined with the expertise of experienced qualified installers. Draper, Inc., is not responsible for improper installation, application, testing or workmanship related to the product at place of installation. Please retain all instructions for future use.
3. Open cartons lengthwise.
4. Locate and lay out all pieces.
5. Inspect all boxes to make sure you have received the proper LCD Wall and parts.
6. If you have any difficulties with installing, servicing or operating your LCD Wall, call your dealer or Draper, Inc., 765 987-7999.

## Section 2 - Components

### DMI 'X' Bracket Assembly Components

Part#:C041.144

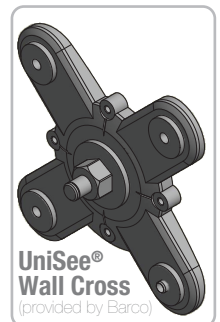
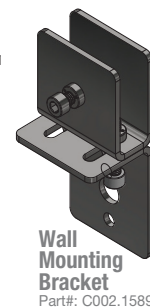
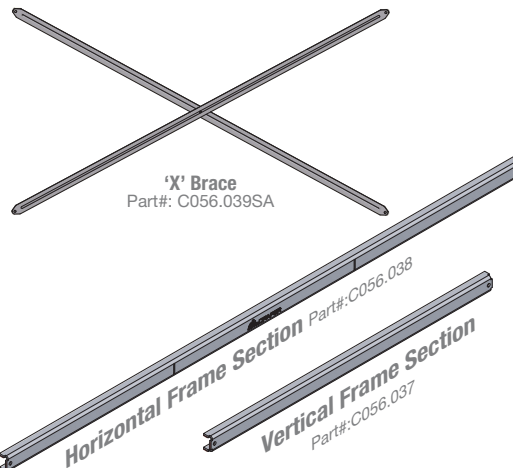
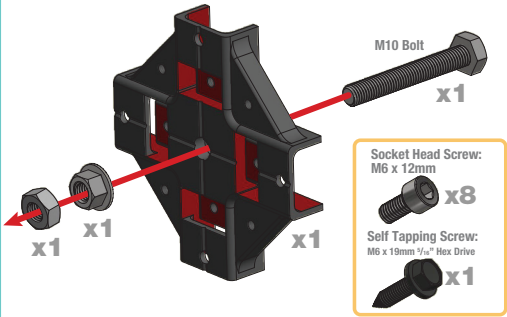

Section 3 - Assembled Dimensions & Wall Bracket Spacing

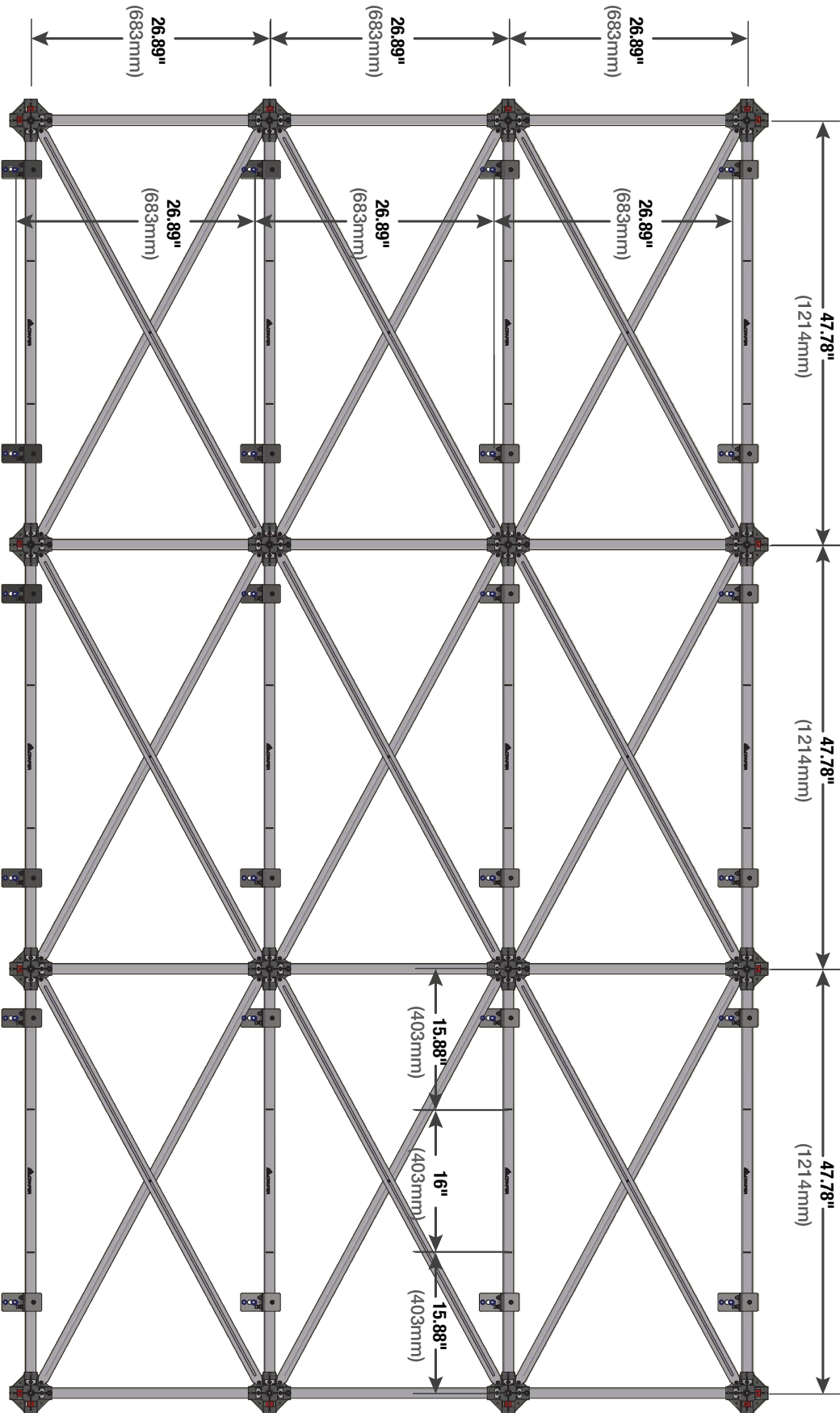

Figure 1

**READ BEFORE BEGINNING:**

Use this as a reference while assembling the wall.  
To ensure a successful installation, the structure **MUST** be assembled in the order specified on pages 6-11.

The structure must be installed perfectly **LEVEL!**  
The LCD Wall is a precise product. Small deviations in accuracy will compound as the installation progresses.

**ALWAYS CHECK FOR LEVEL BEFORE ADDING A SECTION**

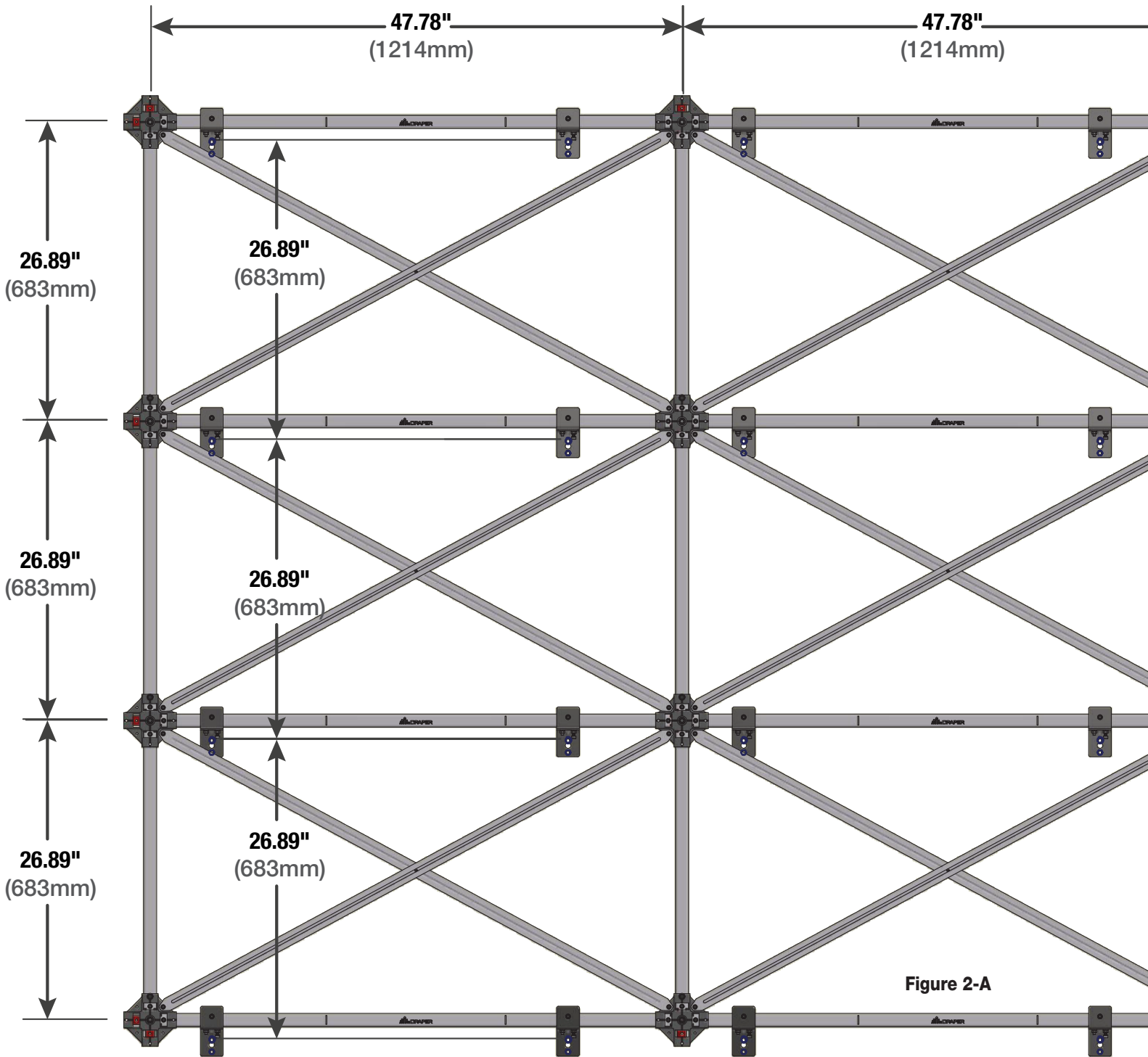
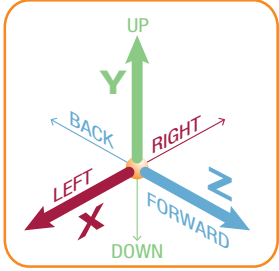

Figure 2-A

**AXIS REFERENCE**



**Wall Mounting Bracket Placement**

**TOP EDGE OF UNISEE PANEL**

**2.35"**  
(60mm)

**CENTER of TOP mounting hole**

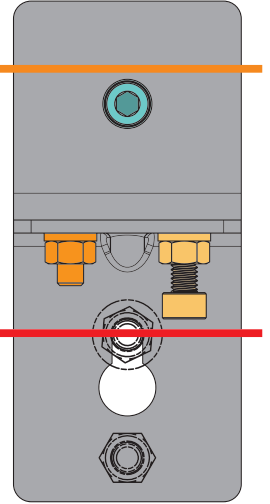

Figure 2-B

**MOUNTING WALL BRACKETS TO STRUCTURE**

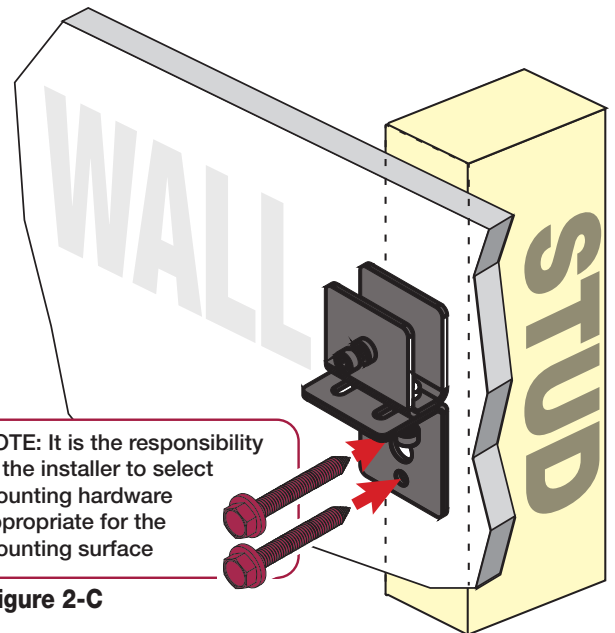

Figure 2-C

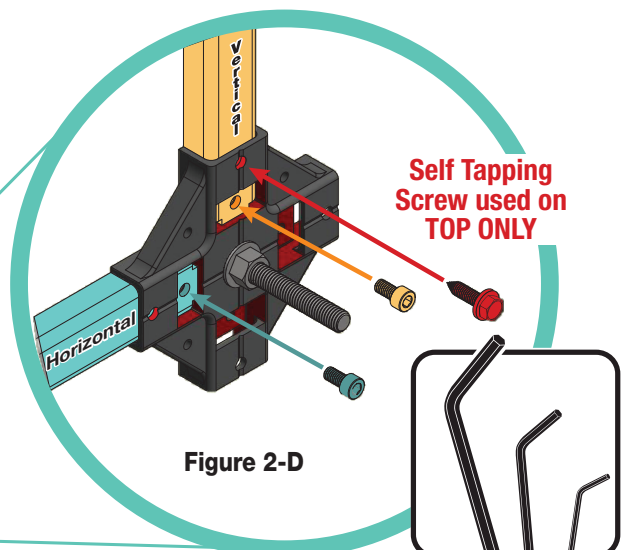
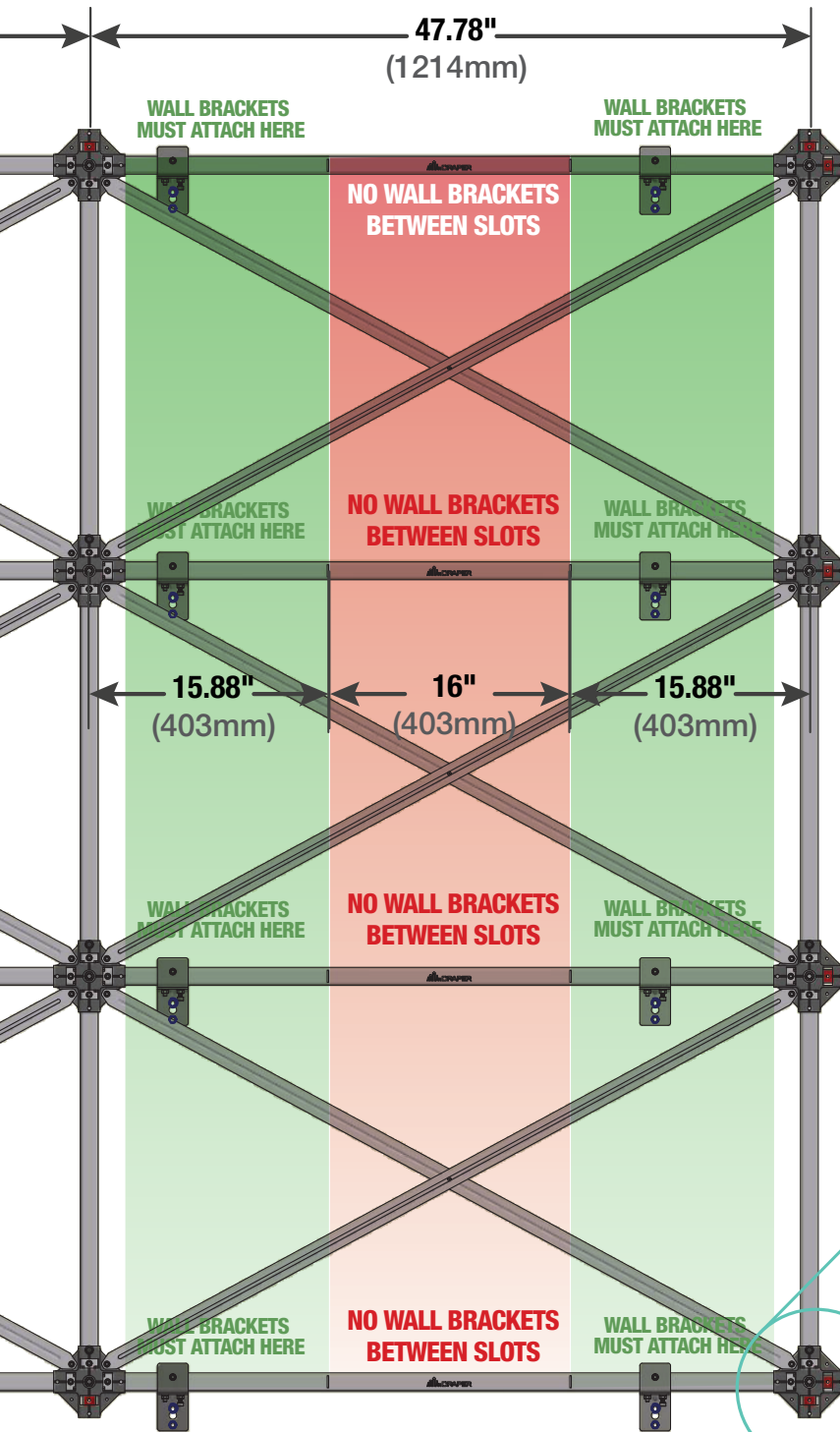

Figure 2-D

No. 5 HEX WRENCH

Section 4 - **Assembling a Single Draper Mount Interface Section**

1. Assemble the Draper Mount Interface on the floor (see Fig. 3-A).  
You will need a hex wrench and a power drill with a  $\frac{5}{16}$ " socket driver.
2. Connect the frame pieces and secure them with the provided hardware (see Fig. 3-B Below).

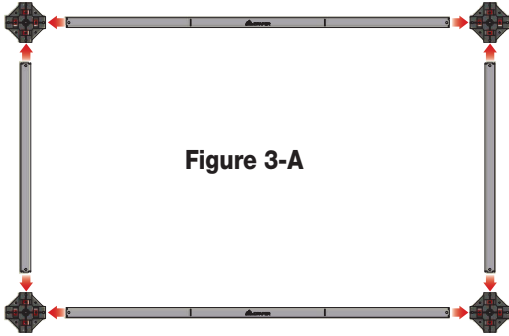

Figure 3-A



POWER DRILL

Self Tapping Screw:  
M6 x 19mm  $\frac{5}{16}$ " Hex Drive



Barco UniSee  
Service Tool



No. 5 HEX WRENCH



10mm, 15mm &  
17mm WRENCHES

Socket Head Screw:  
M6 x 12mm

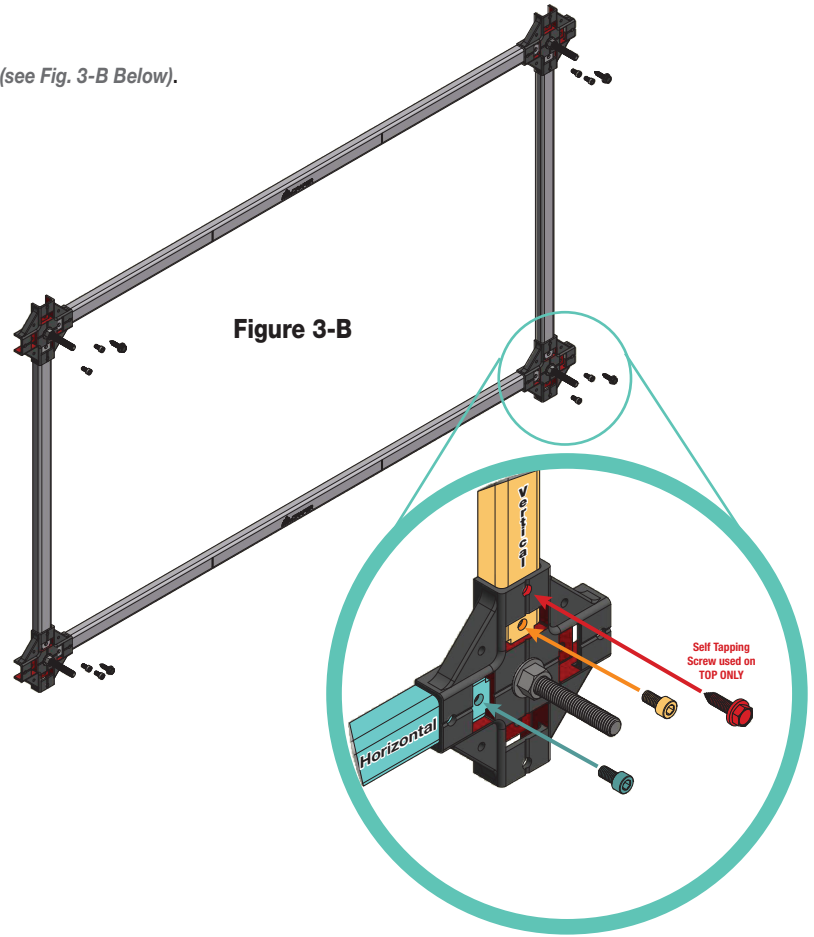

Figure 3-B

Section 5 - **Extending Draper Mount Interface Assembly**

1

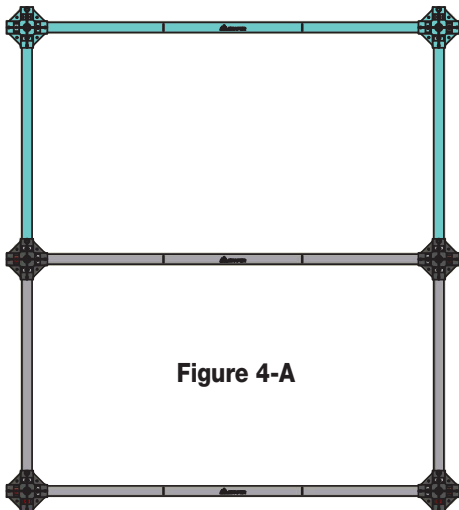

Figure 4-A

2

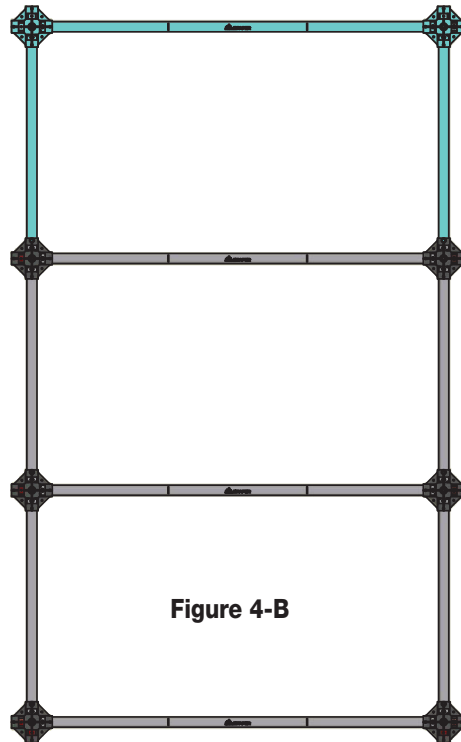

Figure 4-B

3

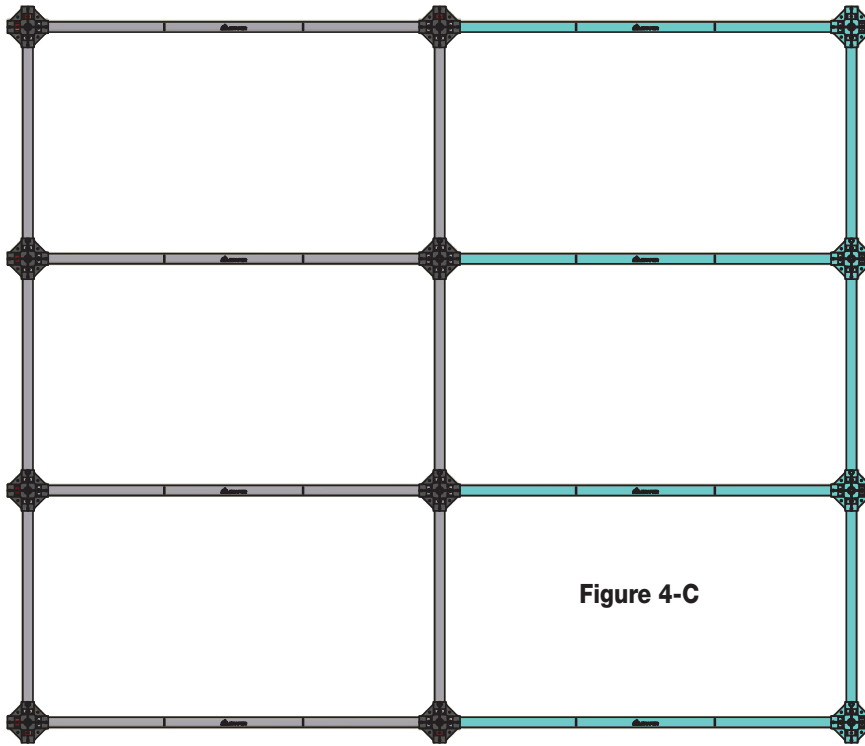

Figure 4-C

4

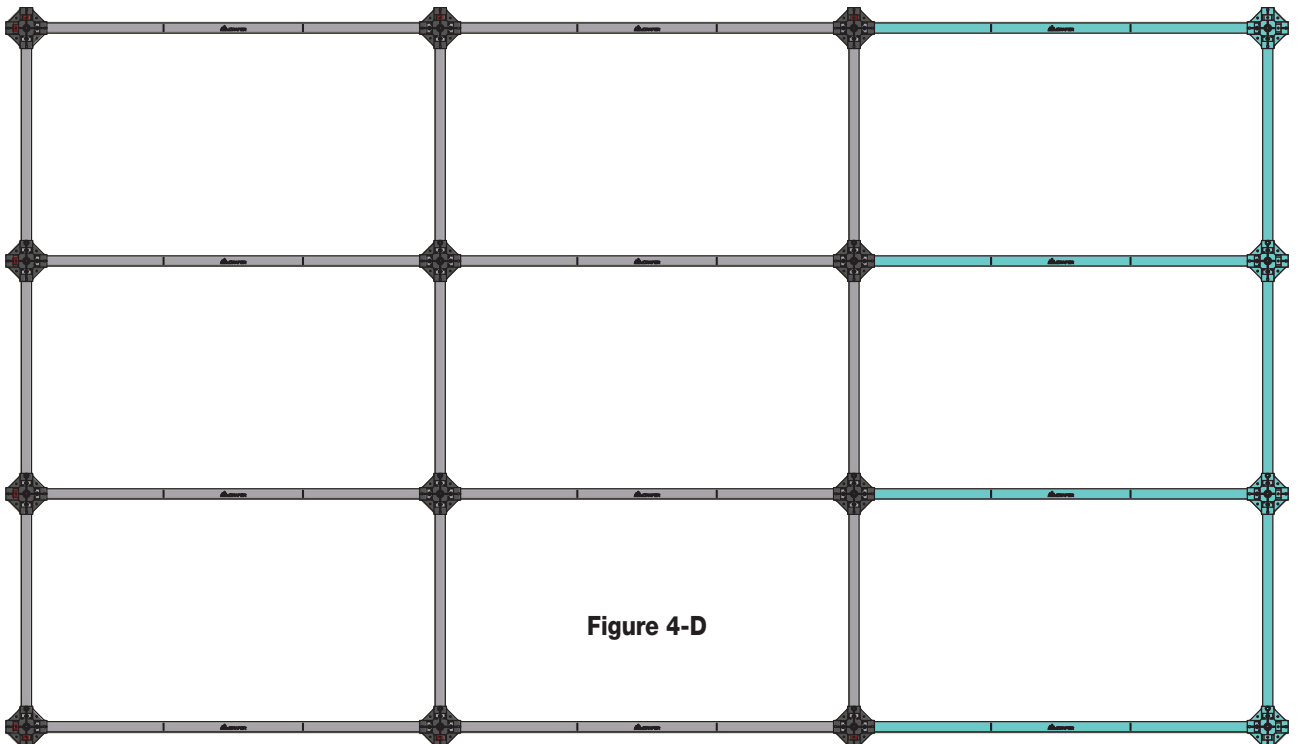

Figure 4-D

Section 6 - Attaching 'X' Bracing

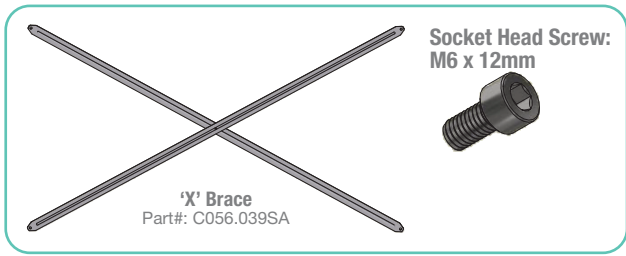
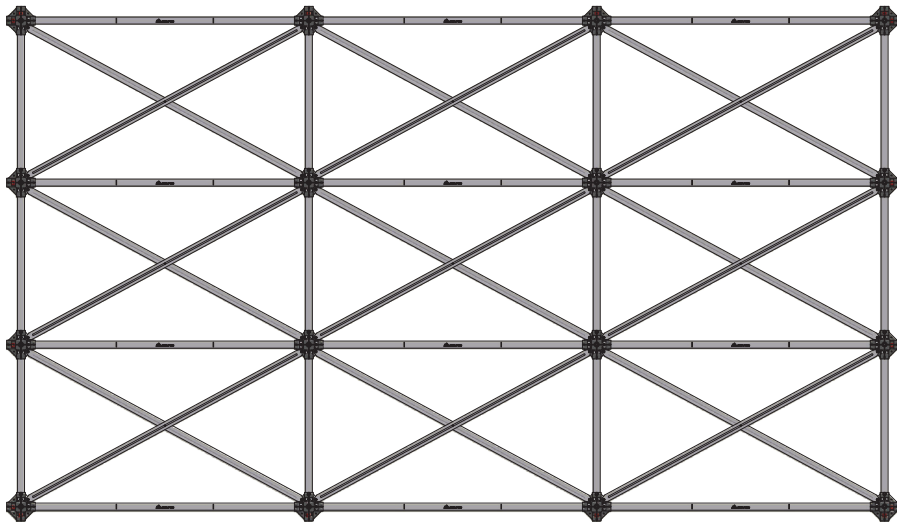
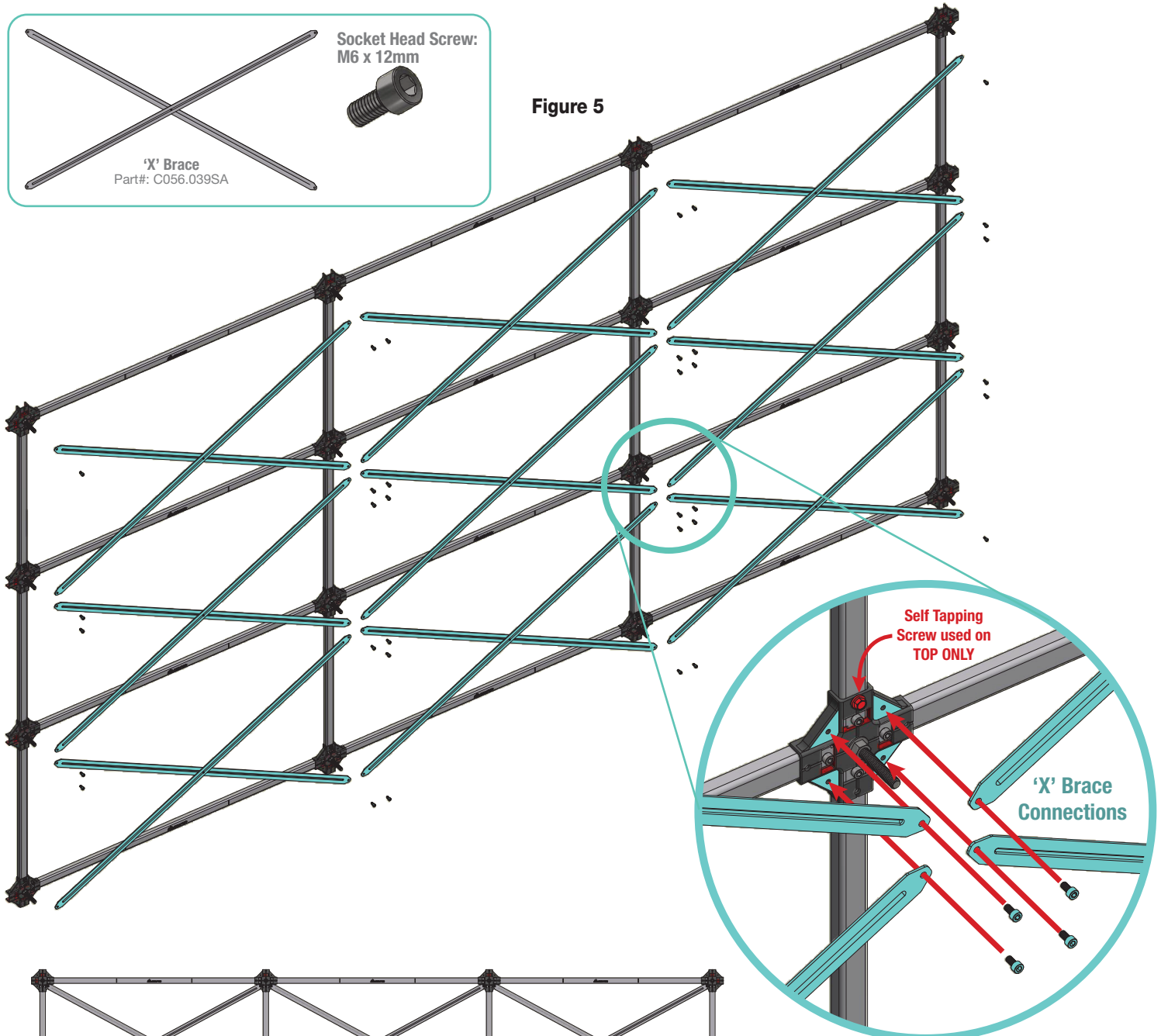

Figure 5





Section 7 - Attaching the Top Row of Brackets to Wall

**Wall Mounting Bracket Placement**

**TOP EDGE OF UNISEE PANEL**

**2.35" (60mm)**

**CENTER of TOP mounting hole**

1. Determine the exact placement of the **TOP EDGE** of the Barco UniSee Panels.
2. Measure **2.35" (60mm)** down from the **TOP EDGE** and install the Top Row of Wall Mounting brackets in accordance with Fig.6-B . below.

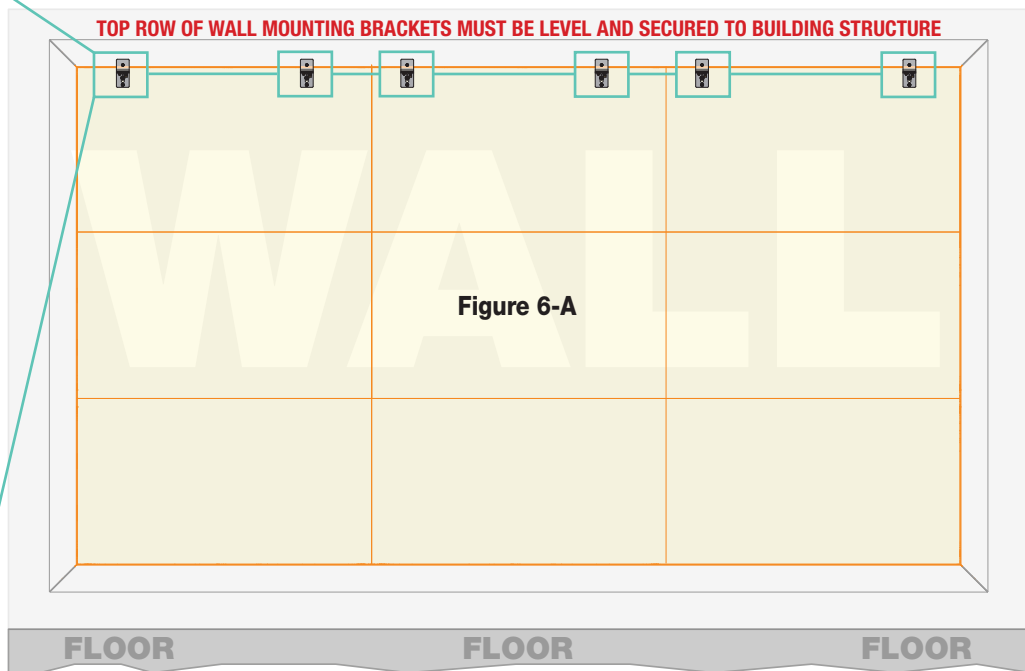

**MOUNTING WALL BRACKETS TO STRUCTURE**

**Figure 6-B**

**NOTE:** It is the responsibility of the installer to select mounting hardware appropriate for the mounting surface



Section 8 - Hanging Draper Mount Interface from Top Row of Wall Brackets

**1**

**Figure 7-B**

**2**

**Figure 7-C**

**X-Axis Adjustment**

**Tighten Set Screw**

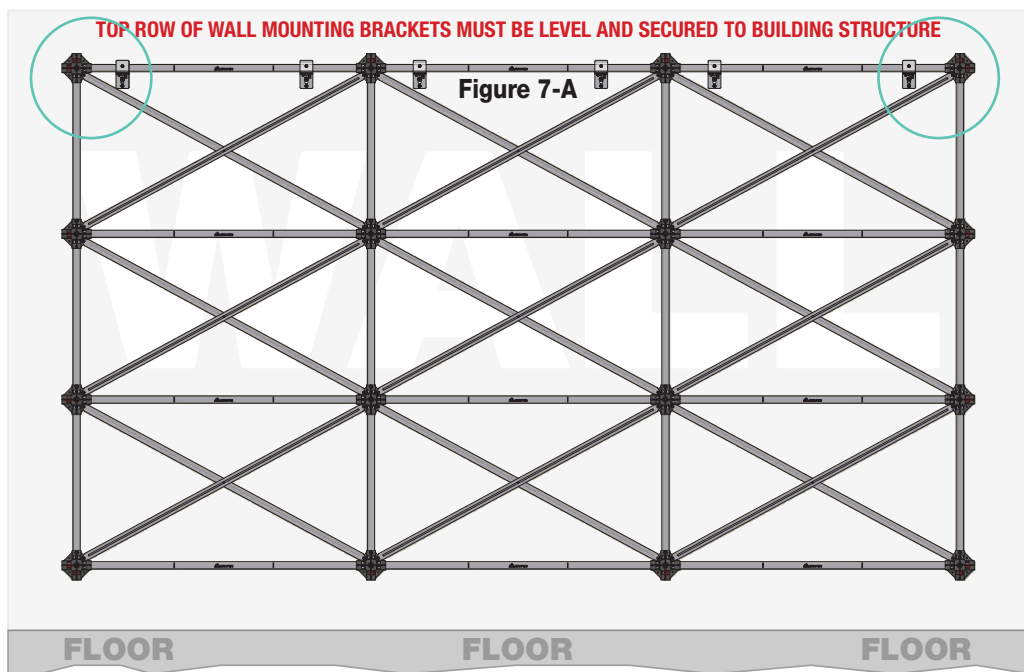

### Section 9 - Attaching Remaining Wall Brackets

1. Install the remaining wall brackets (see fig. 8 below). All wall brackets should be initially installed with the Z-Axis flush against the wall.

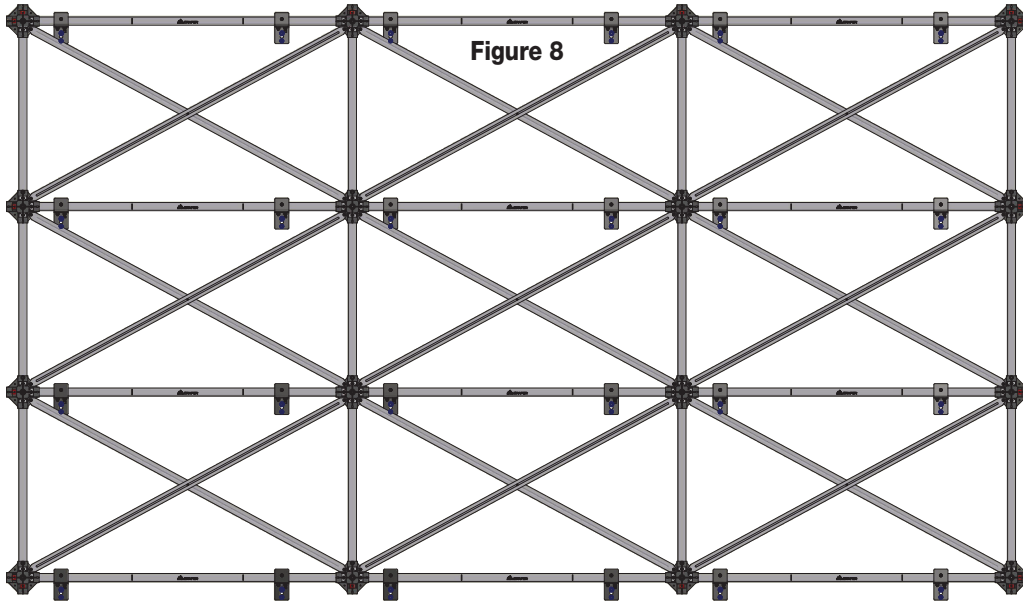

MOUNTING WALL BRACKETS TO STRUCTURE

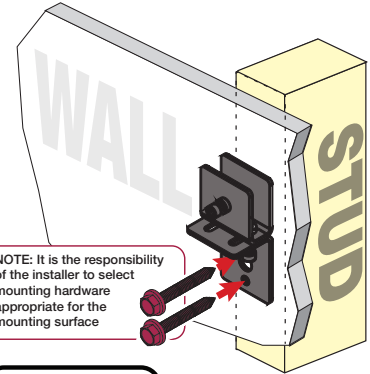

### Section 10 - Adjusting Z-Axis of wall brackets to achieve a perfectly flat surface

1. Set a laser level on the floor and project it upwards parallel to the wall (see fig. 9 below).
2. Align the laser beam with the M10 bolt that extends out FARTHEST from the wall.
3. Adjust the Z-Axis of the wall brackets to align with the M10 bolt from step 2 (see fig. 9). All of the M10 bolts must be aligned with the laser level before attaching the Wall Crosses.

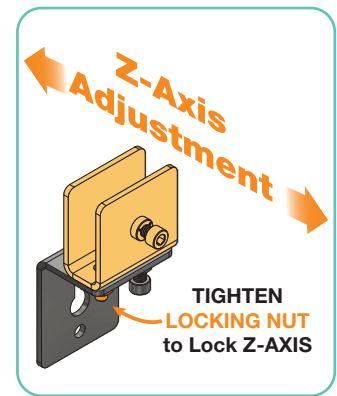
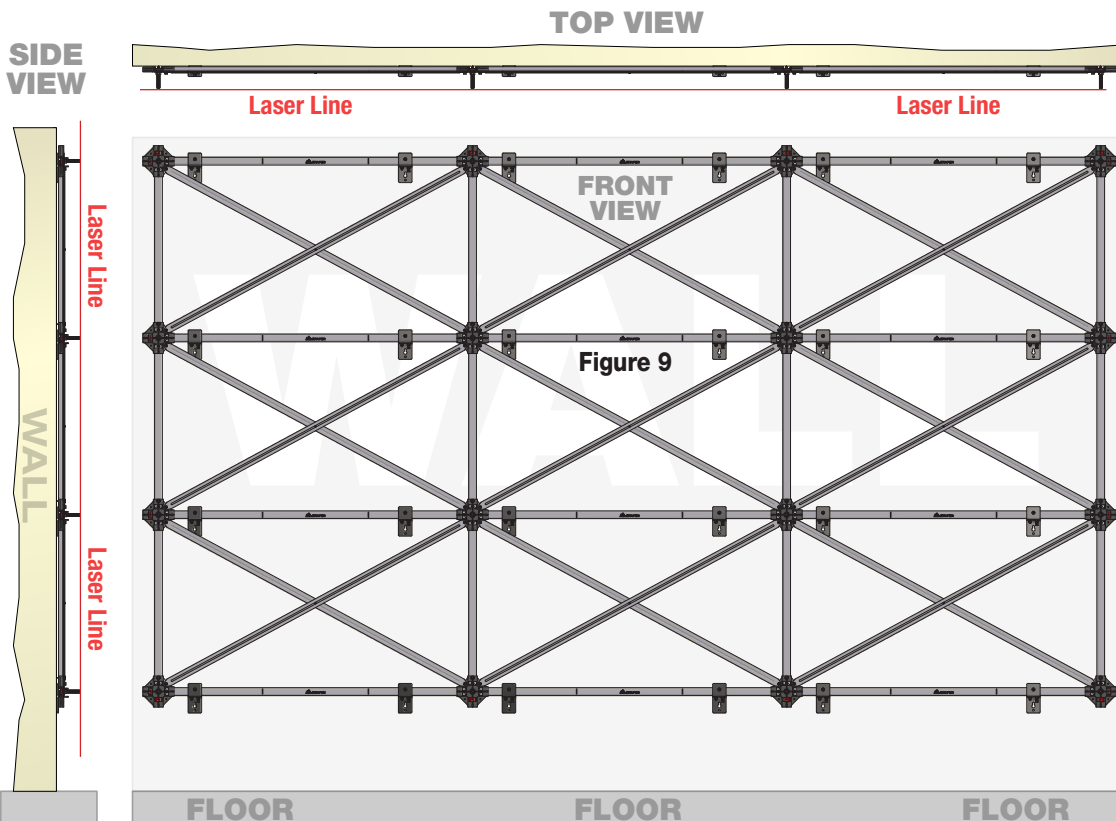

Adjustable Wall Mount Bracket  
See Page 12 for details

Section 11 - Wall Cross Attachment and Alignment

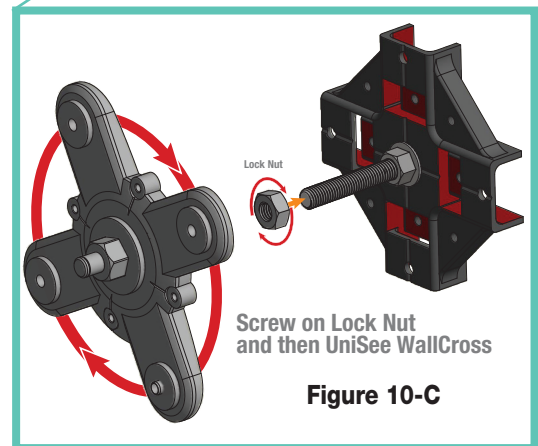
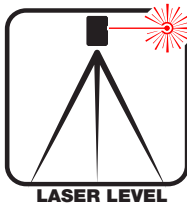
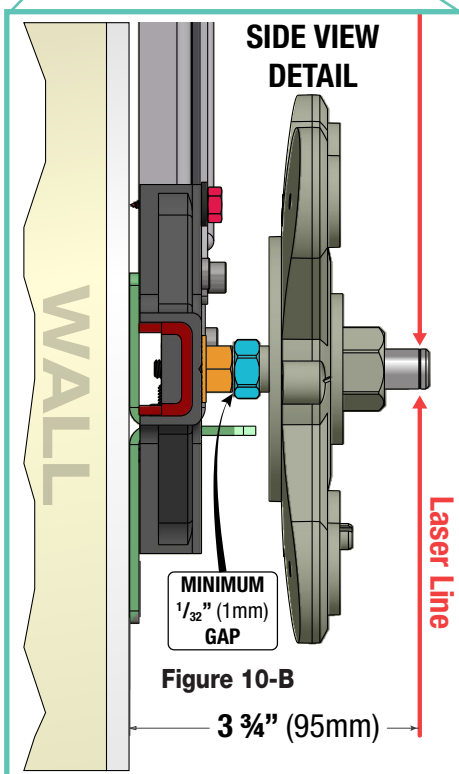
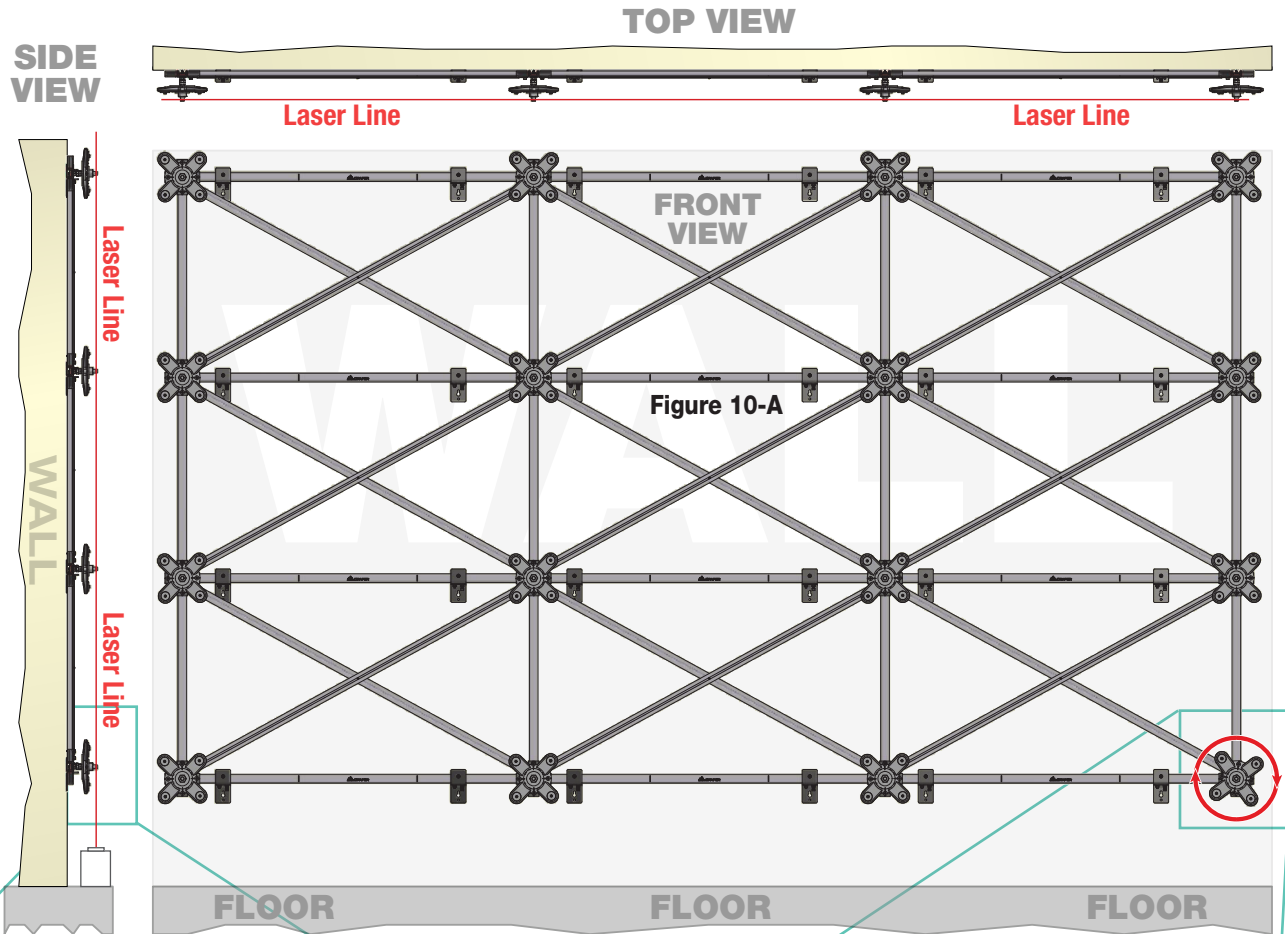

Section 12 - Making X, Y, and Z Axis Adjustments

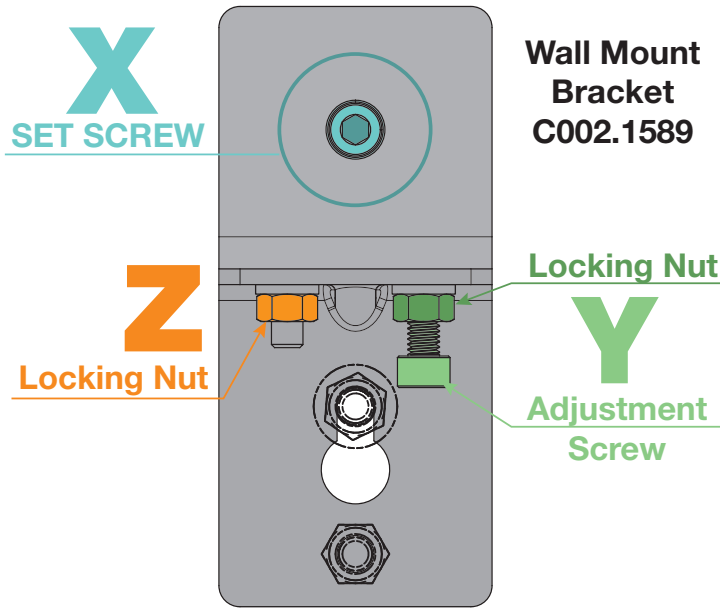
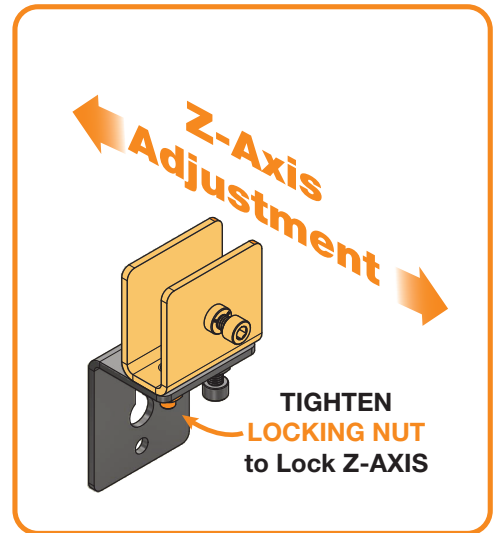
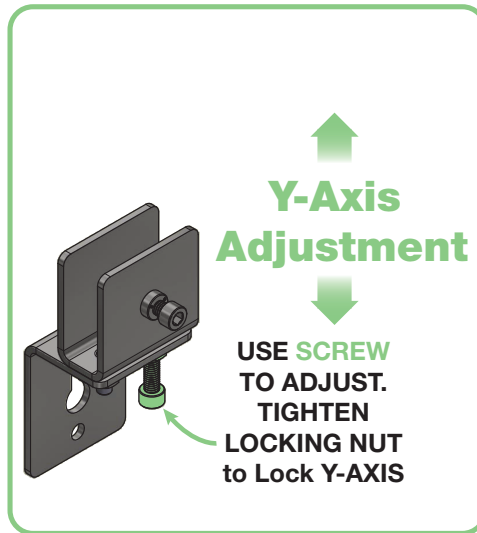
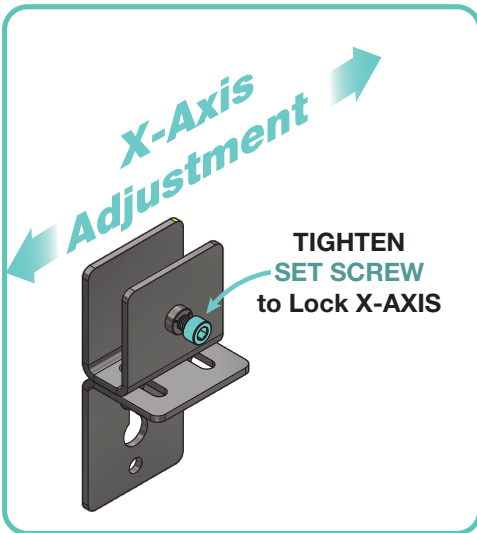

Figure 11



Barco UniSee Service Tool



No. 5 HEX WRENCH



10mm, 15mm & 17mm WRENCHES

If you have any difficulties installing or servicing your LCD wall, call your dealer or Draper, Inc.