



DRAPER®

FOCUSED ON INNOVATIVE SOLUTIONS

infocomm

JUNE 8 – 14, 2019

- 1** SmartTrim™ & Draper® Mount Interface for Barco UniSee®
- 2** 2x2 LCD Video Wall Freestanding
- 3** Custom Mobile Case Solution featuring SONY Crystal LED
- 4** 3x3 Cutaway LED Video Wall featuring Leyard TVF
- 5** Curved LED Video Wall featuring Absen Acclaim

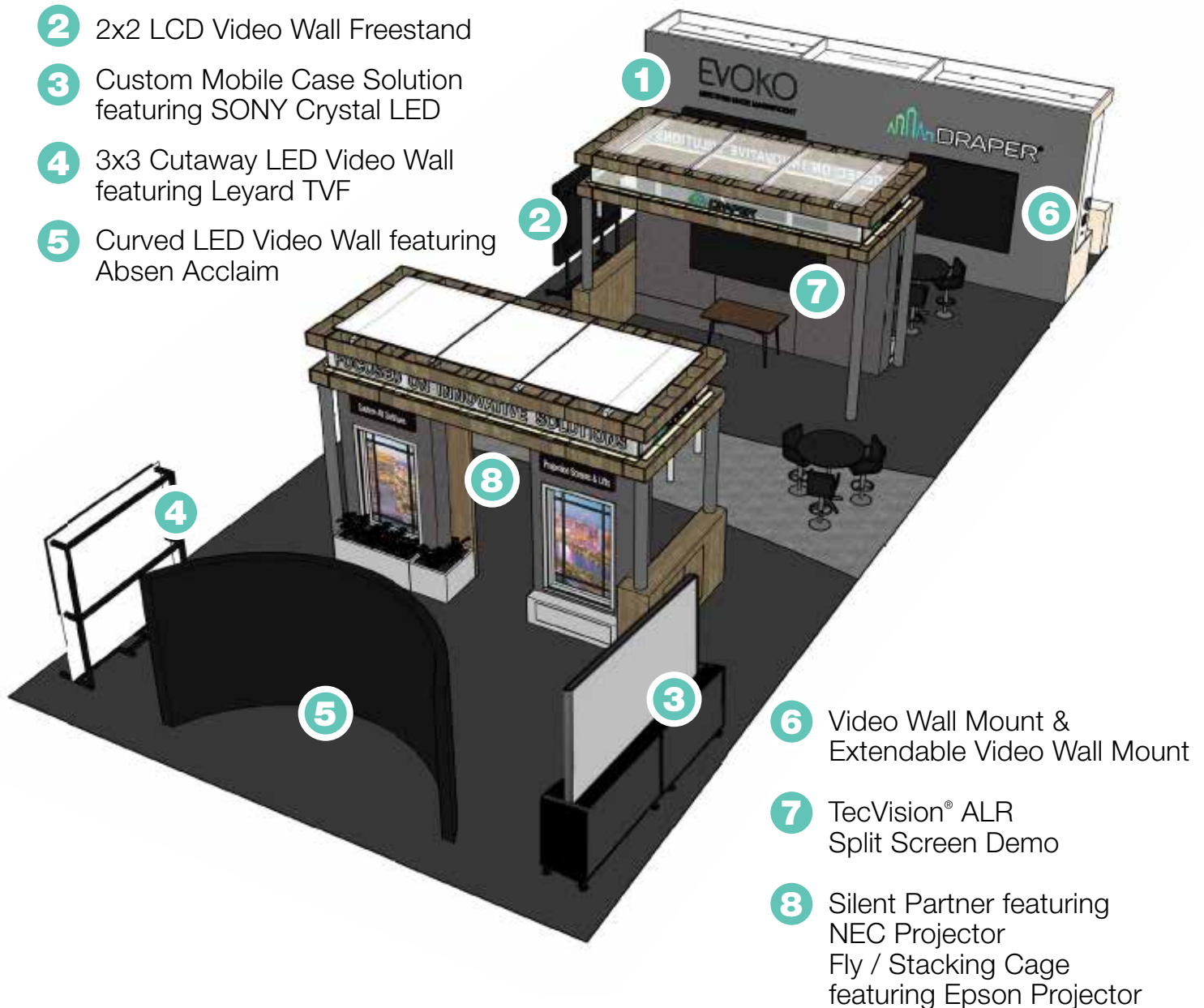

- 6** Video Wall Mount & Extendable Video Wall Mount
- 7** TecVision® ALR Split Screen Demo
- 8** Silent Partner featuring NEC Projector Fly / Stacking Cage featuring Epson Projector

TRIM & MOUNT SmartTrim™ & Draper® Mount Interface for Barco Unisee®

1

MODULAR TRIM SOLUTION FOR BARCO UNISEE VIDEO WALLS

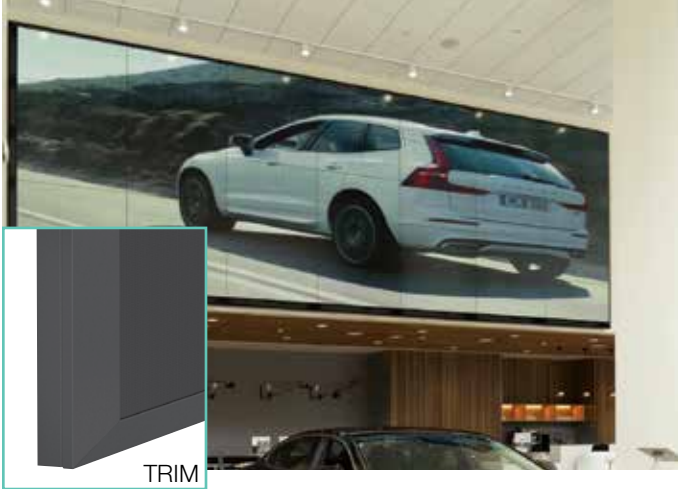

- Patent pending trim solution co-developed with SMS Smart Media Solutions.
- Simple and elegant trim for a wide range of configurations.
- Textured matte black finish; optional colors available.
- Easily installed after the video wall has been mounted.
- Easily removed for quick service access.
- Bottom panel flange vented; side/top flanges vented based on configuration.
- For tailored and unique solution needs, contact Draper.
- Design protected.

MOUNT INTERFACE FOR BARCO UNISEE VIDEO WALLS

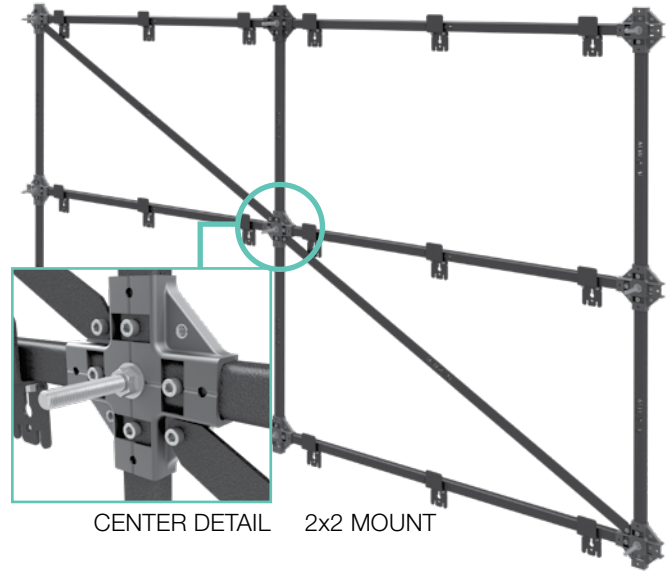

- Precisely aligns any flat Barco Unisee wall configuration.
- Eliminates wall inconsistencies, mounting directly to structure.
- Mount interface and brackets allow one person installation.
- Properly aligns panels, safely distributing weight, and works with SmartTrim™.
- Available September.

VIDEO MOUNT 2x2 LCD Video Wall Freestanding

ICON ACE FREESTAND CONFIGURABLE FLOOR SUPPORTED LCD STRUCTURE

2

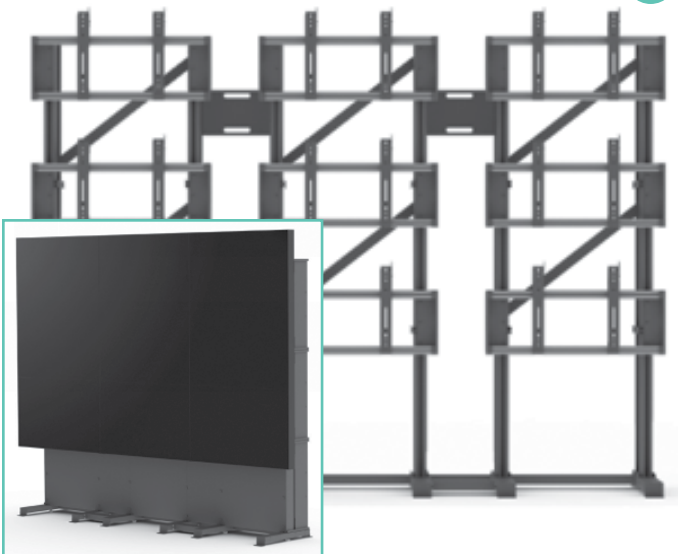

- For 46" or 55" LCD displays (VESA 800 x 400mm).
- 2 x 2, 3 x 3, 4 x 4 array configurations.
- X / Y / Z axis adjustment for perfect display alignment.
- Option for cladding on bottom, sides, and back.
- No curved array.

Custom Mobile Case Solution Featuring SONY Crystal LED

PORTABILITY WITH SUPERB VISUALS

3



- Rugged case and structure prevents flexing.
- Easy to ship, move and set up.
- Fits large, heavy displays and touch sensitive displays.
- Stable, attractive design can be placed anywhere.

CUSTOM STRUCTURE 3x3 Cutaway LED Video Wall featuring Leyard TVF

4

EXTREME AND ULTRA-NARROW BEZEL LCD DISPLAYS

Draper partnered with Leyard and Planar to design an LED mounting solution for the Leyard® TVF Series video wall.

- ADA-compliant solution.
- Independent X-Y-Z adjustments for fast and flawless installation.
- Native 16:9 HD sizes include 5 x 5 (137" D), 6 x 6 (164" D), 8 x 8 (219" D), and more.
- Custom sizes and aspect ratios are available using the same design.

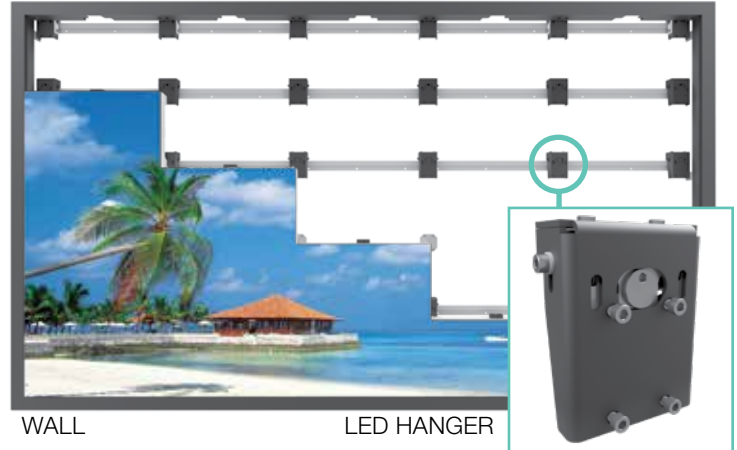

CUSTOM STRUCTURE Curved LED Video Wall Featuring Absen Acclaim

5

TAILORED SOLUTION

Draper worked with Absen to develop a tailored mounting solution for the Acclaim series LED panels. The Acclaim series has pixel pitches available from 1.2 to 3.8 in a true 16:9 aspect ratio.

- Provides a faceted curved array through precise alignment between each column of panels.
- Complete solution is provided with all needed hardware including side cladding and lower ventilated filler panels.
- Can be tailored for flying applications and is easily adaptable to other manufacturers' products.

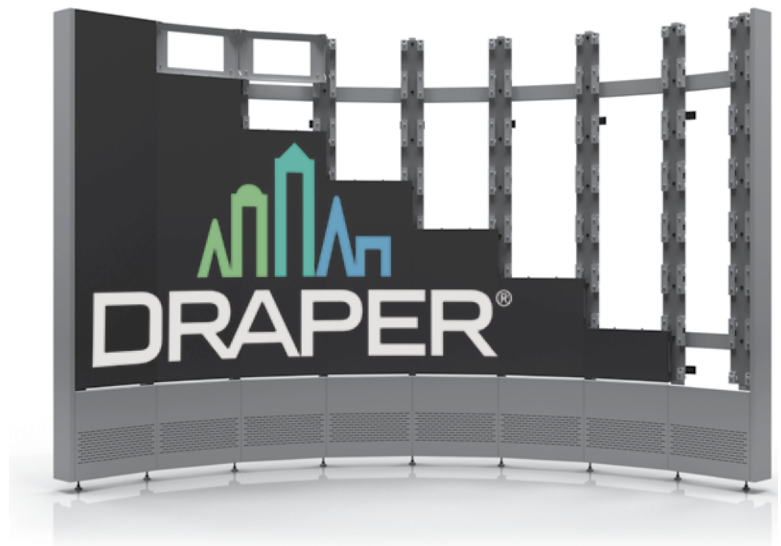

LCD VIDEO WALL MOUNTS Video Wall Mount & Extendable Video Wall Mount

6

CORE SOLUTION

A cost-effective and modular way of building a video wall. Simply choose as many mounts as you need.

VIDEO WALL MOUNT

- 37" - 65" LCD displays (VESA vertical pattern 100 - 400 mm).
- 1 mount required per LCD display.
- 220 lbs capacity per mount.
- X / Y / Z axis adjustment for perfect display alignment.
- Recommended for 1- 2 high arrays.

EXTENDABLE VIDEO WALL MOUNT

- Includes scissor mechanism for easy service (extends 6.25", 16 cm).
- 100 lbs capacity per mount.
- X / Y / Z axis adjustment for perfect display alignment.
- No limitation on array height or width.

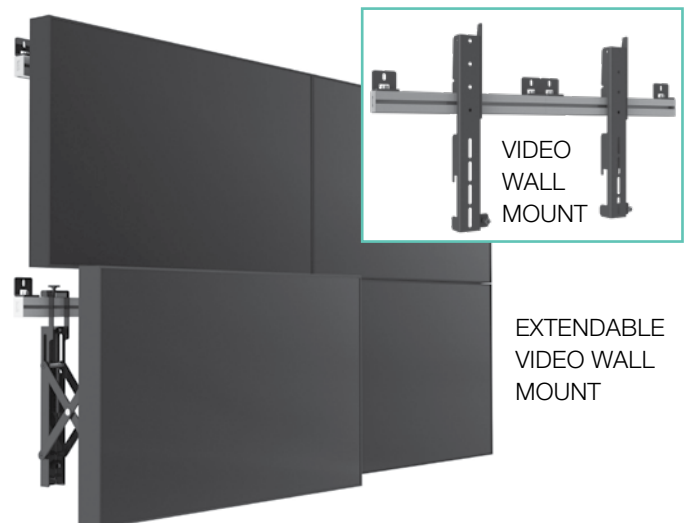

TECVISION ALR SPLIT SCREEN DEMO



7

AMBIENT LIGHT REJECTING (ALR) COMPARISON



CS1200X ALR

AMBIENT LIGHT REJECTING Surface

Narrow Viewing Cone / Superior Contrast / On-Axis Gain of 1.2 / ALR: 82%

CS1200X ALR performs very well in spaces where there is high ambient light and narrow viewing angles. Lens/Throw distance ratio for best brightness uniformity: 1.7:1 or longer. FORMULATED FOR COLOR ACCURACY AND ISF CERTIFIED

8K
READY!

XT1000V MATT WHITE

Extra Wide Viewing Cone / Typical Contrast / On-Axis Gain of 1.0

The perfect matt white diffusing surface. Recommended for use with all types of projectors provided ambient light can be reasonably controlled.

4K
READY!

PROFILE + Maximum image width up to 30' (914 cm) wide, depending on surface selection. Mimics the flat panel look with a thin bezel frame, borderless option available. The Profile+ fixed frame screen offers larger sizing options, making it ideal for home theaters, churches, and corporate training rooms.

PROJECTOR Silent Partner™ Projector Enclosure

8

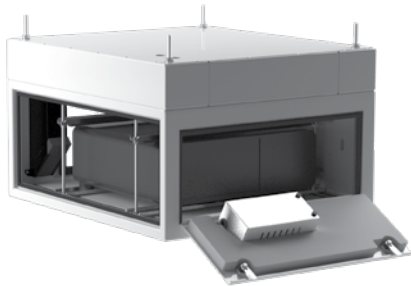

- Available in three sizes. Projector sound enclosure designed to reduce the amount of projector noise. Designed to hold projectors up to 15,000 lumens.

FEATURES:

- Reduces projector noise by about 25 dBA.
- Convolved exhaust airflow path for optimum noise attenuation.
- UL94V fire rated acoustic insulation foam.
- Low noise, variable speed exhaust fan.
- Thermostatic fan control.
- 100 to 240V.
- Inlet dust filter.
- Threaded inserts provide easy install for mounting below ceilings.
- Removable, lockable side doors with optical grade port glass.
- Easy access rear lamp door.
- Can be attached to lifts to conceal them when not in use.
- Projector clamp firmly holds projector for tabletop or ceiling orientation.



Projector Fly Cage

- Available in five size ranges: small, medium, large, wide-small, and wide-large with the ability to custom design to specific sizes. Allows mounting projectors from almost anywhere. Easily attaches to cheeseborough clamps to provide quick, secure mounting to truss. Multiple cages can be stacked.

DRAPER PARTNERS EVOKO

- Presenting with us in our booth. EVOKO, making meetings smoother, more cost efficient and stylish.