

B

B

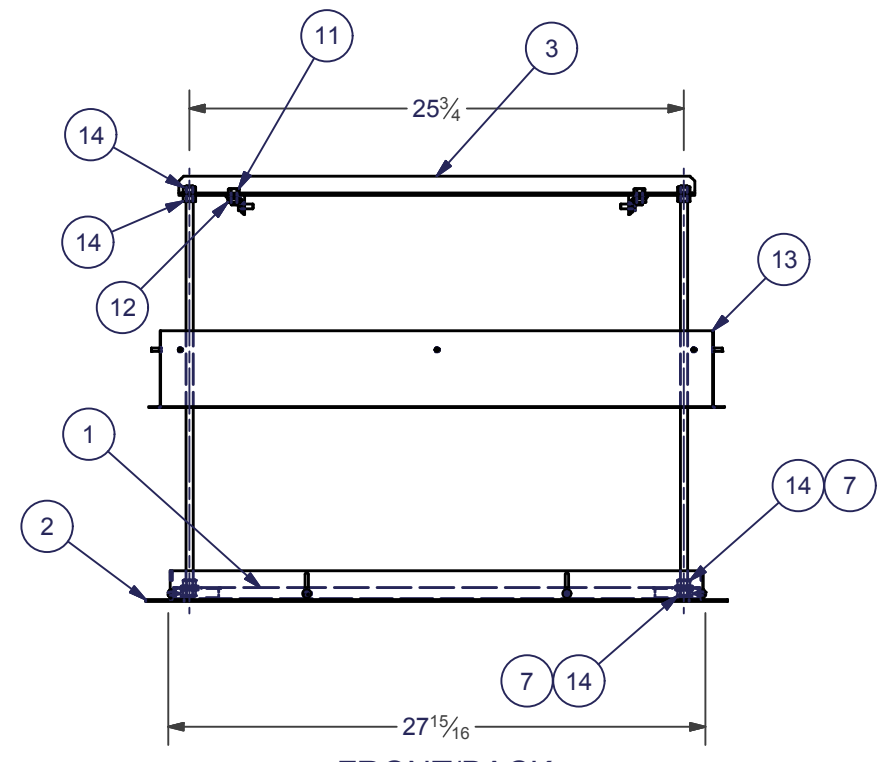
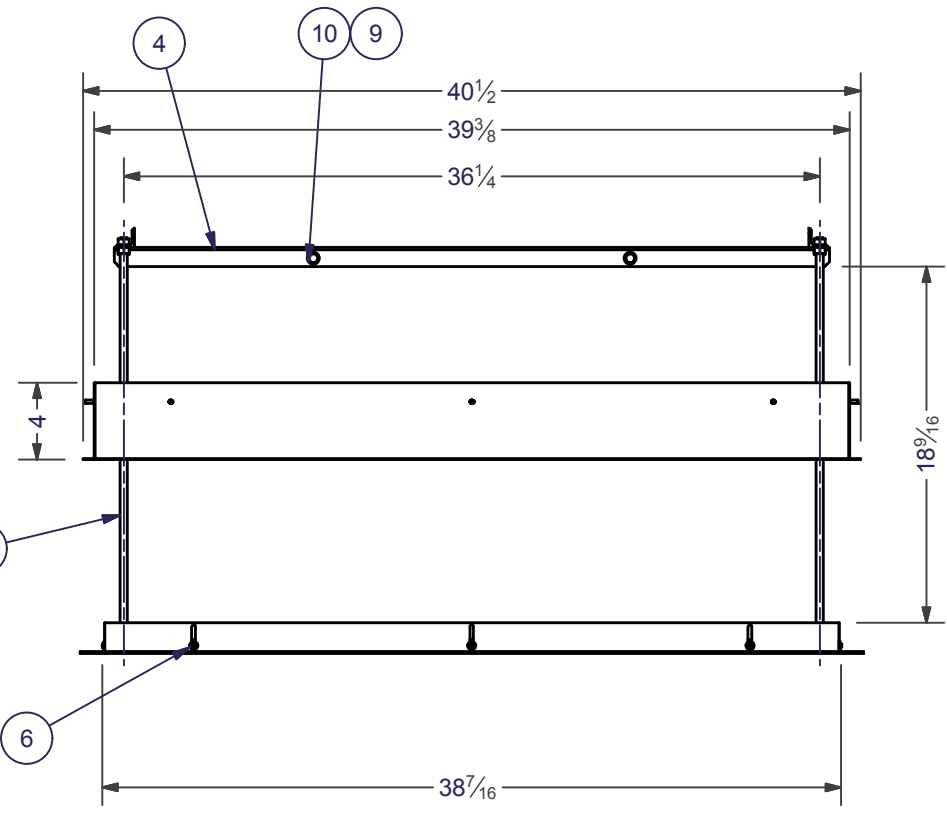
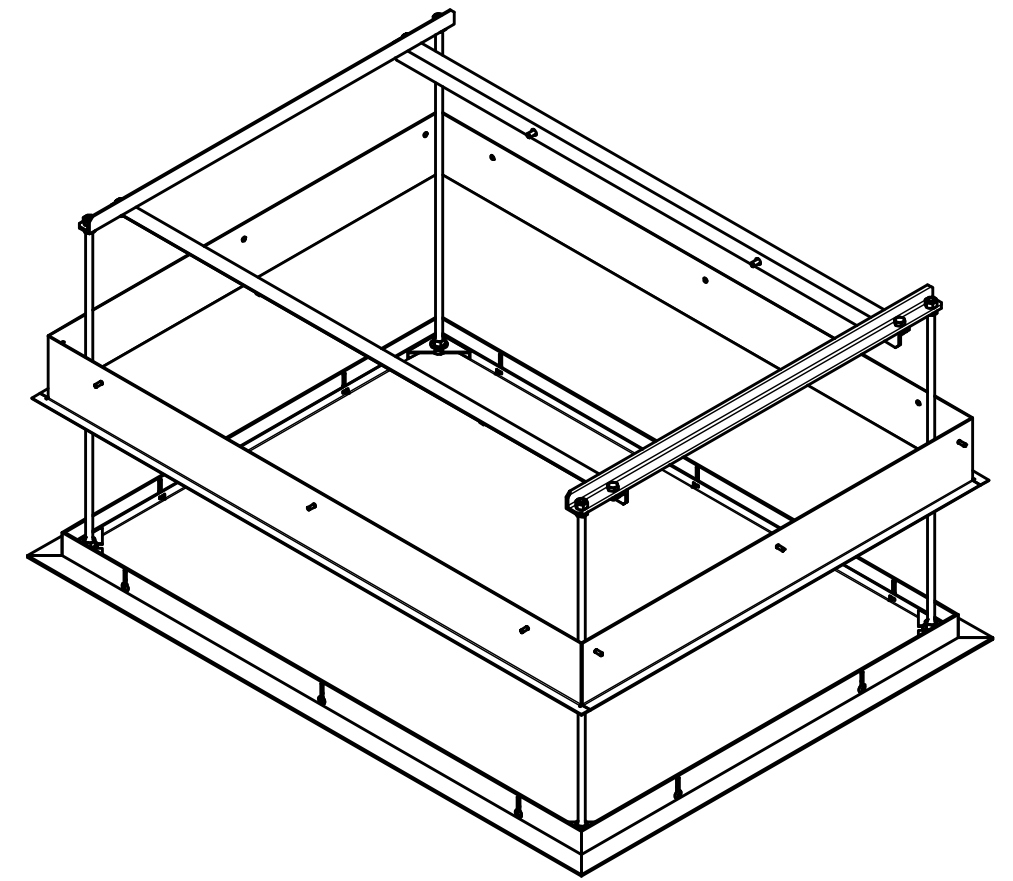
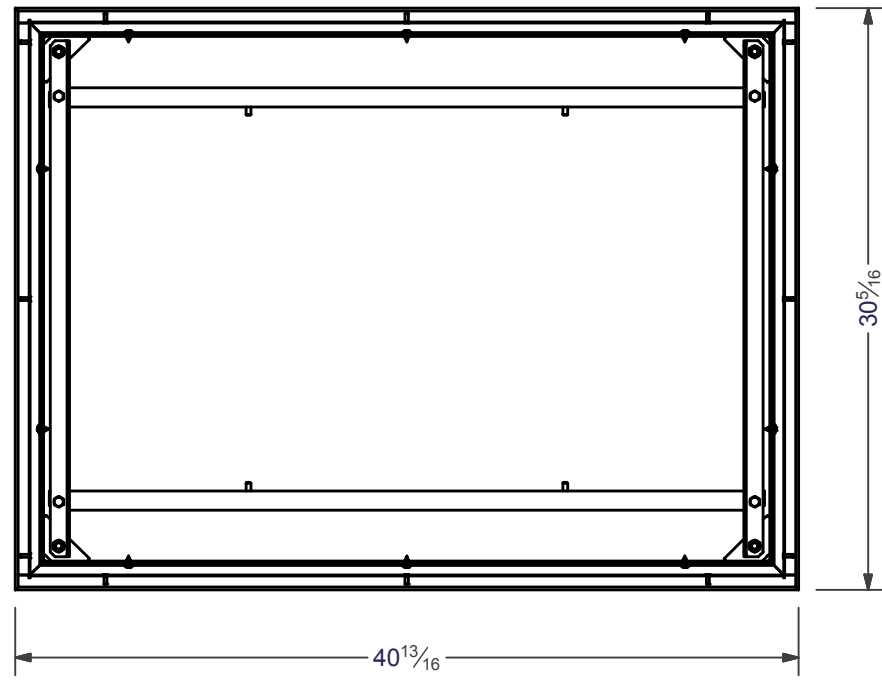

ITEM	QTY	PART NUMBER	DESCRIPTION
1	1	C044.199.07SA	PANEL, E ASSEMBLED CLOSURE
2	1	C028.619.07SA	FRAME, E TRIM
3	2	C002.920.07SA	BRACKET, E FRONT/BACK ANGLE
4	2	C002.921.07SA	BRACKET, E END ANGLE
5	4	C077.037.49	Rod, Threaded 3/8-16 x 21 3/8" L Zinc
6	10	C020.082	SCREW, 10-16 X 1/2" 6 LOBE TRUSS HEAD AB E-WHITE
7	8	C013.050	Washer .375 I.D. x .875 O.D. x .064"TK GRD 2 Zinc Flat
9	4	C020.152	SCREW .25-20 X .625 HEX HD GRD2 ZINC CAP PART 1
10	4	C013.033	WASHER, 1/4" FLAT
11	4	C020.321	SCREW 5/16-18X5/8 HEX HD CAP GR5 ZINC
12	4	C018.045	NUT 5/16-18 ZINC HEX KEPS
13	1	C028.612.07SA	FRAME, E TRIM RING
14	16	C018.027	NUT, 3/8-16 HEX GRD 2 NSF

A

A

SIDE

FRONT/BACK

<p><b>TOLERANCES UNLESS NOTED</b></p> <p>2 PLC. DECIMAL: ±.01"                  3 PLC. DECIMAL: ±.005"                  ANGULAR: ±1°                  FRACTIONAL: ±1/32"</p>	DESIGNED BY: senochs	8/30/2010		DRAPER, INC. 411 S. PEARL STREET SPICELAND, INDIANA 47385-0425 www.draperinc.com	
	DRAWN BY: senochs	9/8/2010			
	CHECKED BY:			TITLE:	E Ceiling Finish Kit
	MFG APPD BY:			MATERIAL:	
PROPRIETARY DRAWING NOTICE: THIS DOCUMENT CONTAINS CONFIDENTIAL, PROPRIETARY INFORMATION OF DRAPER, INC., IS THE PROPERTY OF DRAPER, INC., AND MUST BE RETURNED UPON REQUEST. NEITHER RECEIPT NOR POSSESSION THEREOF CONFERS ANY RIGHT TO OWN, REPRODUCE, USE, OR DISCLOSE IN WHOLE OR IN PART, ANY SUCH INFORMATION WITHOUT WRITTEN AUTHORIZATION FROM DRAPER, INC.			PAPER SIZE:	FINISH:	
			SCALE:	REV: SHEET: 1 OF: 1	
			DWG NO. - PART NO.	300285	

REV	DATE	ECO	BY	DESCRIPTION
REVISION HISTORY				