

CASE STUDY

WINDOW SHADES

A CUSTOM SOLUTION FOR A BIG, MOVEABLE HEADACHE



In all, more than 8600 shades with custom brackets were delivered for the Marina Heights project. Dealer: Progressive Commercial Interiors, LLC. Tempe, Arizona. Architect: Ryan Companies, Inc., Minneapolis, Minnesota. Photographer: Matt Oberer, mattphoto, Albuquerque, New Mexico.

- When Steve Hawes, the Principal at Progressive Commercial Interiors, LLC., in Tempe, Arizona, got the job providing window shades to the Marina Heights project, he knew it was going to be big.

The buildings, home to State Farm Insurance, required more than 8,600 Draper XD Clutch FlexShades to be delivered and installed during the 19 month-long construction process.

“The sheer number of shades made this a big project,” Hawes said, “but there were other factors, as well. There were five buildings, 47 floors, multiple floors often requiring simultaneous installation, plus these shades are 10 feet high, so there’s the need for scaffolds and ladders.”

But those problems weren’t the worst of it. At a pre-construction meeting with the general contractor after being awarded the first part of the job, Building D, Hawes got the news.

“Custom brackets were required to avoid impacting the moveable storefront, which was designed to flex with building movement,” Hawes said. “Attachments had to be made to horizontal mullions only, and they could not attach to vertical mullions.”

After discussions with Walters and Wolf, the company that designed the moveable storefront, Hawes’ next move

was to contact Draper. He quickly brought Solar Control Solutions’ technical manager, Clint Childress (LEED® AP), up to speed. Clint spearheads Draper’s custom solar control solutions efforts.

“It’s fairly straightforward in situations like this,” Childress said. “A problem is identified to us—in this case the shades, which are designed to mount side by side at a vertical mullion, cannot be attached to the vertical mullion. Our first step, as always, was to get a detail drawing of the mullion.”

Clint then worked with Draper’s dedicated solar control solutions design engineer to come up with an alternative mounting solution—custom mounting brackets that allowed the shades to be attached to the horizontal mullion.

“After we developed the solution, we sent out a 3D drawing indicating what we thought would be the best way forward,” Childress said. “They came back with some suggestions, and we were able to quickly modify the design to incorporate their ideas.”

continued on next page

CASE STUDY: A CUSTOM SOLUTION FOR A BIG, MOVEABLE HEADACHE

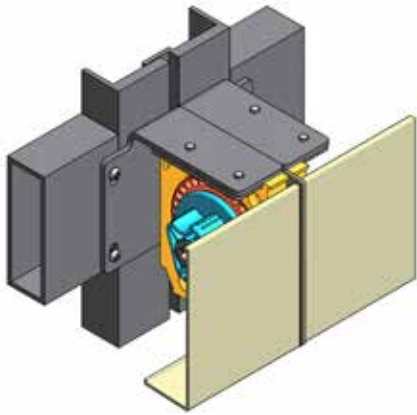

Based on a detail drawing of the horizontal mullion, Draper engineers produced a 3-D drawing of a custom bracket. After some feedback the design was slightly modified and approved.



The final bracket is designed to avoid attachment to the moveable storefront.

The final step in the design process was producing 3D-printed sample brackets to test with a mock-up section of mullion. The custom design was approved, and Draper manufactured the brackets.

“Working through this process with Clint and the engineering group at Draper was fantastic,” Hawes said. “It was quick and efficient and the 3D drawings they provided were impressive.”

The installation started in May of 2015, and was completed in December 2016.

Draper offers a full array of customization possibilities, from modifying current products to designing and manufacturing one-of-a-kind, one-off solutions.

“One big advantage to working with us when these things crop up is that we can see it through the long haul, over years of design, project development, and completion,” Childress said. “Sometimes the issue is with aesthetics, sometimes it’s the available space, sometimes it’s the site conditions, as in this case. Whatever the problem is, we can make a solution happen!”

To learn more about Draper’s custom shade capabilities, visit draperinc.com/go/CustomShades.htm.

For more information about Progressive Commercial Interiors, visit pciaz.com.

draperinc.com/whitepapers_casestudies.aspx