

# somfy®

## Programming Guide

Somfy Digital Network™ (SDN) Keypad Configuration Software



# Programming Guide

## Somfy Digital Network™ (SDN) Keypad Configuration Software

Rev A | July 2018 | Prepared by B. DeBonis, J. Hamilton, R. Vitale

### Contents

I.	Parts Needed -----	3
	Software	
	Hardware	
II.	Software Installation -----	3
III.	Explanation of User Interface -----	4
	Configuration Section	
	Button Programming Section	
	Command Options	
IV.	Programming Example -----	7
V.	Popular Programming Options -----	8
VI.	1-to-1 Configuration -----	8

# I. Parts Needed

## Software:

- Somfy Digital Network™ (SDN) Keypad Configuration Software

## Hardware:

- USB to RS-485 Converter for SDN (Somfy Part #9015260)
- SDN DecoFlex Digital Keypad (Somfy Part #1811252 or several other part #s)
- Bus Power Supply (Somfy Part #1822440)
- Category 5 or higher patch cable terminated TIA 568B – Suitable length to connect PC to SDN Bus
- Laptop PC

# II. Software Installation

1. Download the latest SDN Keypad Configuration software. *\*When possible, install as administrator.*  
This can be downloaded from:  
<https://www.somfysystems.com/support/tools/configuration-tools-software>
2. Connect the USB to RS-485 converter to any USB port on your laptop.
3. Go to Windows Start menu and search for Device Manager and open the program.
4. Go to Ports and click to expand it.
5. Make note the COM Port number listed for the RS-485 port.  
**Note:** If RS-485 Port is not listed under “Ports”, you must install the driver for the USB to RS-485 Converter.  
This can be downloaded from:  
[https://support.advantech-bb.com/download?product\\_model\\_name=BB-485USB9F-2W-LS#Driver](https://support.advantech-bb.com/download?product_model_name=BB-485USB9F-2W-LS#Driver)
6. Right click on the RS-485 Port and click Properties.
7. Click the tab for Port Settings and make sure that the settings are as follows:

- Bits per second: 4800
- Data Bits: 8
- Parity: Odd
- Stop Bits: 1
- Flow Control: None

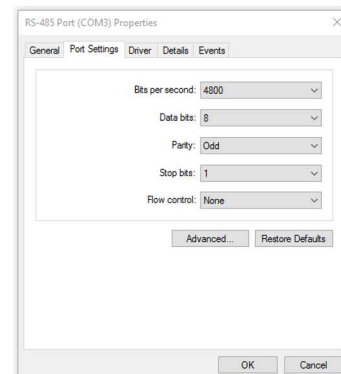
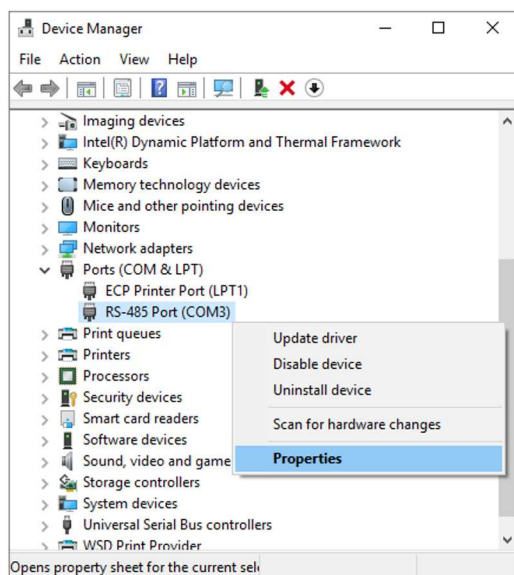

8. Open the Somfy Digital Network™ (SDN) Keypad Configuration Software from the Desktop icon or Windows Start menu.
9. At the top left of the window, select the COM port that you noted from the Device Manager and click on the “Connect” button. You are now connected to the COM port.

**Note:** If there is no COM ports listed in the dropdown box, close the software and make sure the USB cable is connected, and then reopen the software. If there still is no COM port listed, reinstall the driver for the USB to RS485 adapter. Be sure the Keypad Config is the only software running on your computer. Also, if you can not connect to the COM port, make sure that no other software is using that com port.

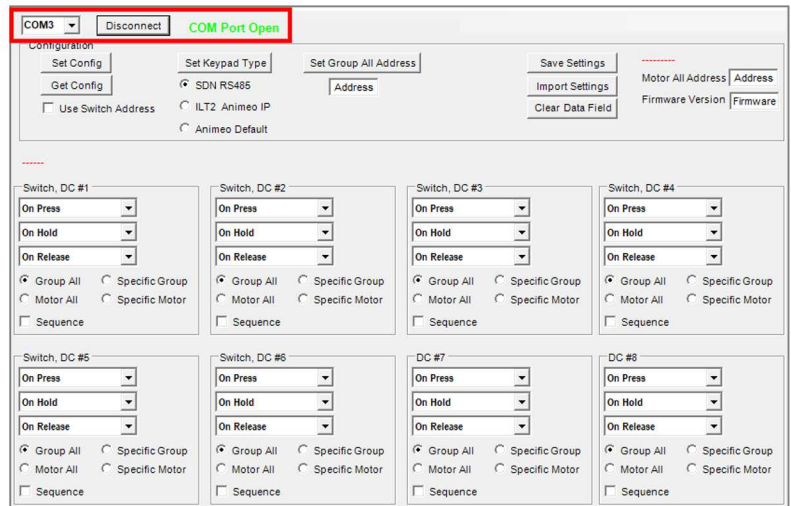

### III. Explanation of User Interface

#### Configuration Section:

- o *Set Config* – Sends all the programming on screen, to the keypad.
- o *Get Config* – Checks and displays all that is currently programmed to the connected keypad.
- o *Set Keypad Type* – Allows you to change the keypad to either an SDN or animeo IP keypad with default configuration. (Only available if keypad is running Firmware version 5.0 or higher)
- o *Set Group All Address* – Allows you to enter a group address for the keypad to control. This also will be used as the keypad’s address. When using animeo IP keypad programming, each keypad will need a unique address in this field.
- o *Save Settings* – Will save all programming made onscreen, to a text file.
- o *Import Settings* – Will import settings from a previously saved file.
- o *Clear Data Field* – Clears all values onscreen. (This does not clear the keypad unless you then press the *Set Config* button.)
- o *Motor All Address* – This is used when making a keypad for testing/troubleshooting to control all motors on the system. Put FFFFFF in this box and select the “Motor All” radio button in the button boxes below. This field can also be populated with any motor address and when the Motor All radio button is selected on that switch button, it will communicate with that address.

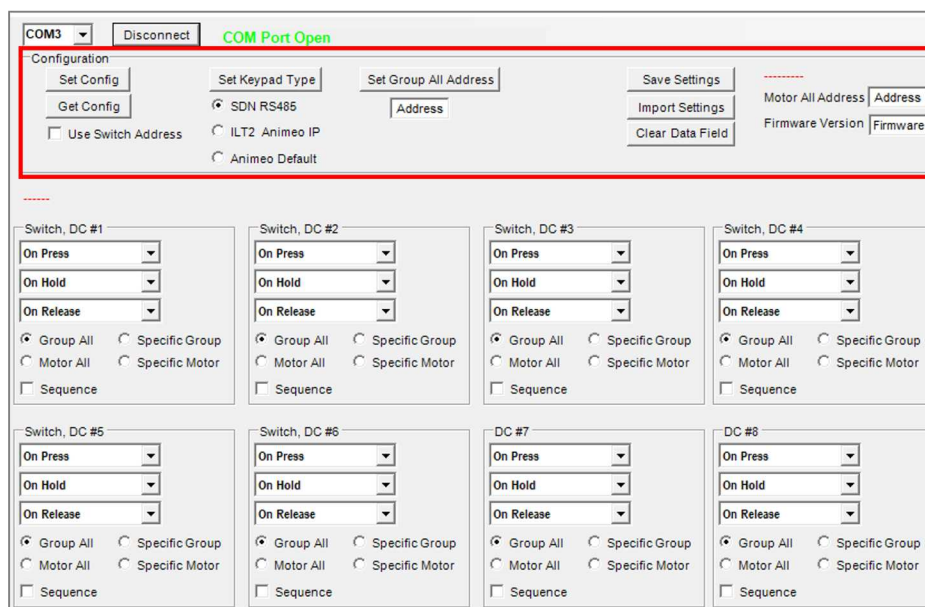

## Keypad Button Programming Section:

- Each Keypad Button is represented by a window labeled "Switch, DC #\_".

**Note:** When programming a 6-Button Keypad, "Switch, DC #4" and "Switch, DC #5" are not used, unless for Dry Contact closures on the back of keypad.

- Each Keypad Button has a dropdown to program a command to happen when you Press, Hold, or Release the button on the keypad. (If you want nothing to happen when you Press, Hold or Release the button, then just leave the dropdown to say "On Press", "On Hold" or "On Release")
- Each section has a *Sequence* check box. When selected, it will turn the section of that Keypad Button purple. This option will enable sequential commands/functions. See "Switch, DC #5" below - the first dropdown box command (A) will act on the first button press, the second dropdown box command (B) will act on the second button press, and so on, that each press on that Keypad Button will cycle commands from A-B-C-B-A.

**Note:** During operation mode, 60 seconds after the last Keypad Button is pressed, the second dropdown box command (B) will be skipped.

- Each section has a choice of four radio buttons. These options will tell each Keypad Button which motor or group to send a command to.
  - Group All – Makes this Keypad Button control all motors in the "Set Group All Address" box [See "Switch, DC #1" below]
  - Motor All – Makes this Keypad Button control all motors in the "Motor All Address" box [See "Switch, DC #2" below]
  - Specific Group - Makes this Keypad Button control only the motors in the specified group [See "Switch, DC #3" below]
  - Specific Motor - Makes this Keypad Button control only the single specified motor [See "Switch, DC #4" below]



COM3
Disconnect
COM Port Open

---

Configuration

Set Config

Get Config

Use Switch Address

Set Keypad Type

SDN RS485

ILT2 Animeo IP

Animeo Default

Set Group All Address

Address

Save Settings

Import Settings

Clear Data Field

Motor All Address

Address

Firmware Version

Firmware

---

Switch, DC #1

On Press

On Hold

On Release

Group All  Specific Group

Motor All  Specific Motor

Sequence

Switch, DC #2

On Press

On Hold

On Release

Group All  Specific Group

Motor All  Specific Motor

Sequence

Switch, DC #3

On Press

On Hold

On Release

Group All  Specific Group

Motor All  Specific Motor

Sequence

Address

Switch, DC #4

On Press

On Hold

On Release

Group All  Specific Group

Motor All  Specific Motor

Sequence

Address

Switch, DC #5 is SEQUENCE

A Go to % 25

B Go to % 50

C Go to % 75

Group All  Specific Group

Motor All  Specific Motor

Sequence

Switch, DC #6

On Press

On Hold

On Release

Group All  Specific Group

Motor All  Specific Motor

Sequence

DC #7

On Press

On Hold

On Release

Group All  Specific Group

Motor All  Specific Motor

Sequence

DC #8

On Press

On Hold

On Release

Group All  Specific Group

Motor All  Specific Motor

Sequence

July 2018 – Rev A

**somfy** Building happiness

5 of 8

## Command Options:

- *On Press* is a placeholder to show where the dropdown is for programming the *On Press* feature. When changed to a function in the dropdown box, this button will activate the function. When *On Press* is left in the dropdown box, nothing will happen when the button is pressed.
- *On Hold* is a placeholder to show where the dropdown is for programming the *On Hold* feature. When changed to a function in the dropdown box, this button will activate the function. When *On Hold* is left in the dropdown box, nothing will happen when the button is pressed. NOTE: A hold is defined as a press that lasts more than 1.5 seconds.
- *On Release* is a placeholder to show where the dropdown is for programming the *On Release* feature. When changed to a function in the dropdown box, this button will activate the function. When *On Release* is left in the dropdown box, nothing will happen when the button is pressed.
- *Up* – Sends motor/groups up to the upper limit.
- *Down* – Sends motor/groups down to the lower limit.
- *Stop* – Stops motor/group movement
- *Go to IP #* – Sends motor/group to a specific IP (Intermediate Position).
- *Next IP Up* – Sends motor/group up to next IP in series.
- *Next IP Down* – Sends motor/group down to next IP in series.
- *Go to Pulse #* – Sends motor/group to specified pulse #.
- *Jog Up X 10 ms* – Sends motor/group up 10 times milliseconds specified.
- *Jog Down X 10 ms* – Sends motor/group down 10 times milliseconds specified.
- *Jog Up Pulse* – Sends motor/group up specified # of pulses.
- *Jog Down Pulse* – Sends motor/group down specified # of pulses.
- *Go to %* – Sends motor/group to specified %.
- *Lock @ Current* – Locks motor/group at current location.
- *Lock @ Up* – Locks motor/group at upper limit.
- *Lock @ Down* – Locks motor/group at lower limit.
- *Lock @ IP #* – Locks motor/group at specified IP (Intermediate Position).
- *Unlock* – Unlocks motor/group that has been locked (Priority of lock/unlock #1 is highest level).
- *Set IP #* – Programs current location as specified IP #.

The screenshot displays the Somfy configuration software interface. At the top, it shows 'COM3' and 'COM Port Open'. Below this is a 'Configuration' section with buttons for 'Set Config', 'Set Keypad Type', 'Set Group All Address', 'Save Settings', 'Get Config', 'Import Settings', 'Clear Data Field', and 'Use Switch Address'. There are also radio buttons for 'SDN RS485', 'ILT2 Animeo IP', and 'Animeo Default', and fields for 'Motor All Address', 'Address', 'Firmware Version', and 'Firmware'. The main area contains eight panels for 'Switch, DC #1' through 'DC #8'. Each panel has dropdown menus for 'On Press', 'On Hold', and 'On Release', and radio buttons for 'Group All', 'Specific Group', 'Motor All', and 'Specific Motor'. A red box highlights the 'On Press' dropdown for 'Switch, DC #1', which is open, showing a list of command options: 'On Press', 'Up', 'Down', 'Stop', 'Go to IP #', 'Next IP Up', 'Next IP Down', 'Go to Pulse #', 'Jog Up X 10 ms', 'Jog Down X 10 ms', 'Jog Up Pulse', 'Jog Down Pulse', 'Go to %', 'Lock @ Current', 'Lock @ Up', and 'Lock @ Down'. Below the dropdown are input fields for '25', '50', and '75', and radio buttons for 'Group All', 'Specific Group', 'Motor All', and 'Specific Motor'.

## IV. Programming Example

1. Connect the USB to RS485 converter to the computer's USB port (see picture below)
2. Connect a CAT5 or higher cable to the RS-485 adapter and to the Data Pass through port on the Bus Power supply.
3. Connect Keypad to the Bus power supply Power/Data port with a CAT5 or higher cable
4. Connect Bus Power Supply to 120v outlet

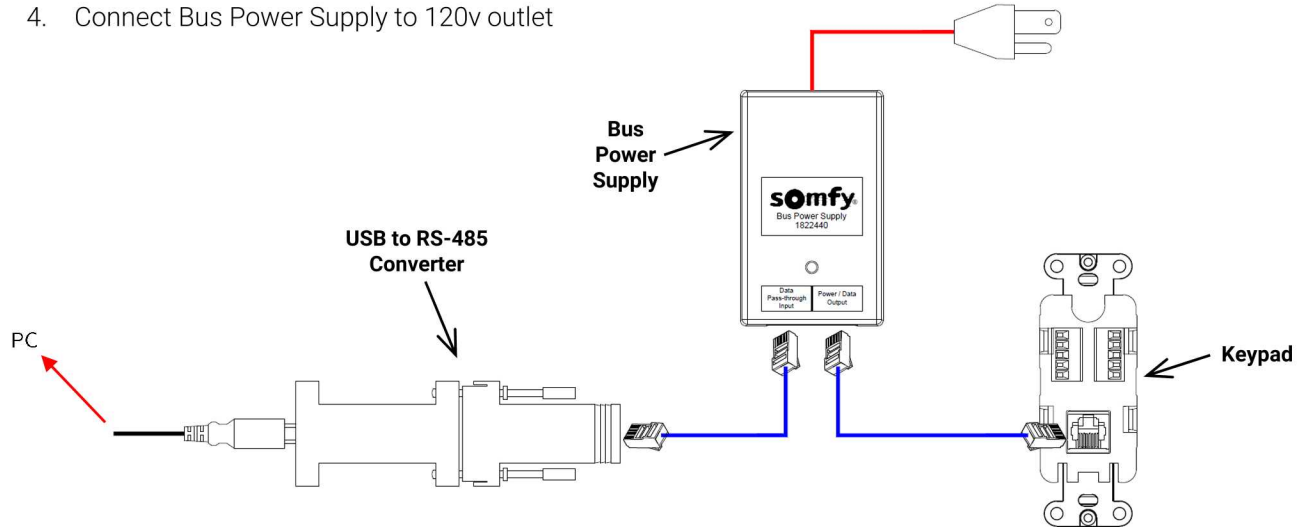

5. Open Somfy Digital Network™ (SDN) Keypad Configuration Software
6. Click the dropdown and select the correct COM port and click Connect
7. Type in the Group Address that you would like this Keypad to control
8. For "Switch, DC #1" change the *On Press* dropdown to *Go to %* and then enter 15 in the box that appeared next to the dropdown
9. For "Switch, DC #2" change the *On Press* dropdown to *Go to %* and then enter 30 in the box that appeared next to the dropdown
10. For "Switch, DC #3" change the *On Press* dropdown to *Go to %* and then enter 50 in the box that appeared next to the dropdown
11. For "Switch, DC #4" change the *On Press* dropdown to *Go to %* and then enter 70 in the box that appeared next to the dropdown
12. For "Switch, DC #5" change the *On Press* dropdown to *Go to %* and then enter 85 in the box that appeared next to the dropdown
13. For "Switch, DC #6" change the *On Press* dropdown to *Stop*
14. For "Switch, DC #7" change the *On Press* dropdown to *Down*
15. For Switch, DC #8" change the *On Press* dropdown to *Up*
16. Click on the "Set Config" button. While the program writes to the Keypad, the light on the front of the Keypad will flash. DO NOT DISCONNECT the Keypad until after the light goes out. (about 5 seconds)

You are now finished programming this keypad and can connect it to any Device Port on the SDN network and it will control the group that you programmed in to it.

## V. Popular Programming Options

---

- To program a momentary button to only move up or down while the button is depressed:
  1. Change the *On Press* dropdown to *Down* or *Up*
  2. Change the *On Release* dropdown of *Stop*
  
- To create a single Keypad Button that can do UP, Stop & Down:
  1. Check the *Sequence* box under the Keypad Button you want to program
  2. Change the *On Press* dropdown to *Up*
  3. Change the *On Hold* dropdown to *Stop*
  4. Change the *On Release* dropdown to *Down*
  
- To dedicate a single 6-Button Keypad to move a specific group up, down or to a specific % at the same time:
  1. Select the *Specific Group* radio button option on each Keypad Button section
  2. Enter the same Group Address on each section
  3. For "Switch, DC #1", change the *On Press* dropdown to *Go to %* and in the box that appears to the right, type "25"
  4. For "Switch, DC #2", change the *On Press* dropdown to *Go to %* and in the box that appears to the right, type "50"
  5. For "Switch, DC #3", change the *On Press* dropdown to *Go to %* and in the box that appears to the right, type "75"
  6. Keep "Switch, DC #4" as is
  7. Keep "Switch, DC #5" as is
  8. For "Switch, DC #6", change the *On Press* dropdown to *Stop*
  9. For "Switch, DC #7", change the *On Press* dropdown to *Down*
  10. For "Switch, DC #8", change the *On Press* dropdown to *Up*

## VI. 1-to-1 configuration (1 Motor powers 1 keypad)

---

- To program a momentary button to only move up or down while the button is depressed:
  1. Using the Grey Motor Cable with Power, connect Somfy Keypad (#1811730) directly to a 120V AC RS485 Motor
  2. The Keypad will need to be programmed with the Motor's address, a group address that is programmed in the Motor, or the FFFFFF address
  3. The Keypad buttons can be programmed in any configuration just like all other SDN Keypads (see *Keypad Button Programming* Section)